Service Manual Outline

Section 1 - Important Information

- A - General Information
- B - Maintenance
- C - Troubleshooting

Section 2 - Removal, Installation and Adjustment

- A - All Models

Section 3 - Sterndrive Unit

- A - Drive Shaft Housing
- B - Standard Rotation Gear Housing
- C - Counter Rotation Gear Housing

Section 4 - Transom Assembly

- A - Minor Disassembly
- B - Major Disassembly

Section 5 - Power Trim

- A - Trim Pump
- B - Trim Cylinders
- C - Dual Power Trim System
- D - Auto Trim II

Section 6 - Steering Systems

- A - Power Steering
- B - Manual Steering

Section 7 - Corrosion Protection

- A - All Models

Important Information

1

Removal, Installation and Adjustment

2

Sterndrive Unit

3

Transom Assembly

4

Power Trim

5

Steering Systems

6

Corrosion Protection

7

Notice

Throughout this publication, “Dangers,” “Warnings” and “Cautions” (accompanied by the International HAZARD Symbol ) are used to alert the mechanic to special instructions concerning a particular service or operation that may be hazardous if performed incorrectly or carelessly. **OBSERVE THEM CAREFULLY!**

These “Safety Alerts” alone cannot eliminate the hazards that they signal. Strict compliance to these special instructions when performing the service, plus “Common Sense” operation, are major accident prevention measures.

DANGER

DANGER - Immediate hazards which WILL result in severe personal injury or death.

WARNING

WARNING - Hazards or unsafe practices which COULD result in severe personal injury or death.

CAUTION

Hazards or unsafe practices which could result in minor personal injury or product or property damage.

Notice to Users of This Manual

This service manual has been written and published by the Service Department of Mercury Marine to aid our dealers’ mechanics and company service personnel when servicing the products described herein.

It is assumed that these personnel are familiar with the servicing procedures of these products, or like or similar products manufactured and marketed by Mercury Marine, that they have been trained in the recommended servicing procedures of these products which includes the use of mechanics’ common hand tools and the special Mercury Marine or recommended tools from other suppliers.

We could not possibly know of and advise the service trade of all conceivable procedures by which a service might be performed and of the possible hazards and/or results of each method. We have not undertaken any such wide evaluation. Therefore, anyone who uses a service procedure and/or tool, which is not recommended by the manufacturer, first must completely satisfy himself that neither his nor the products safety will be endangered by the service procedure selected.

All information, illustrations and specifications contained in this manual are based on the latest product information available at the time of publication. As required, revisions to this manual will be sent to all dealers contracted by us to sell and/or service these products.

It should be kept in mind, while working on the product, that the electrical system and ignition system are capable of violent and damaging short circuits or severe electrical shocks. When performing any work where electrical terminals could possibly be grounded or touched by the mechanic, the battery cables should be disconnected at the battery.

Any time the intake or exhaust openings are exposed during service they should be covered to protect against accidental entrance of foreign material which could enter the cylinders and cause extensive internal damage when the engine is started.

It is important to note, during any maintenance procedure replacement fasteners must have the same measurements and strength as those removed. Numbers on the heads of the metric bolts and on the surfaces of metric nuts indicate their strength. American bolts use radial lines for this purpose, while most American nuts do not have strength markings. Mismatched or incorrect fasteners can result in damage or malfunction, or possibly personal injury. Therefore, fasteners removed should be saved for reuse in the same locations whenever possible. Where the fasteners are not satisfactory for re-use, care should be taken to select a replacement that matches the original.

We reserve the right to make changes to this manual without prior notification.

Refer to dealer service bulletins for other pertinent information concerning the products described in this manual.

Engine Mechanical Components

Many of the engine mechanical components are designed for marine applications. Unlike automotive engines, marine engines are subjected to extended periods of heavy load and wide-open-throttle operation and, therefore, require heavy-duty components. Special marine engine parts have design and manufacturing specifications which are required to provide long life and dependable performance. Marine engine parts also must be able to resist the corrosive action of salt or brackish water that will rust or corrode standard automotive parts within a short period of time.

Failure to use recommended Quicksilver service replacement parts can result in poor engine performance and/or durability, rapid corrosion of parts subjected to salt water and possibly complete failure of the engine.

Use of parts other than recommended service replacement parts, will void the warranty on those parts which are damaged as a result of the use of other than recommended replacement parts.

Replacement Parts

WARNING

Electrical, ignition and fuel system components on MerCruiser Engines and Stern-drives are designed and manufactured to comply with U.S. Coast Guard Rules and Regulations to minimize risks of fire or explosion.

Use of replacement electrical, ignition or fuel system components, which do not comply to these rules and regulations, could result in a fire or explosion hazard and should be avoided.

When servicing the electrical, ignition and fuel systems, it is extremely important that all components are properly installed and tightened. If not, any electrical or ignition component opening would permit sparks to ignite fuel vapors from fuel system leaks, if they existed.

Models Covered in This Manual

Transom Assembly	
Model	Serial Number
MC Alpha One Generation II	OD492742 and Above

MC ALPHA ONE GENERATION II - STANDARD ROTATION	
Model	Serial Number
1.47:1	0F680000 and Above
1.50:1	0D469859 thru OF503723
1.62:1	0F691000 and Above
1.65:1	0D469884 thru OF501799
1.81:1	0F691500 and Above
1.84:1	0D469885 thru OF503021
1.94:1	0F713549 and Above
1.98:1	0D469898 thru OF502356
2.0:1	0L100009 and Above
2.40:1	0D469898 and Above

MC ALPHA ONE GENERATION II - COUNTER ROTATION	
Model	Serial Number
1.47:1	0F728823 and Above
1.50:1	0D350945 thru OF320162
1.62:1	0F729013 and Above
1.65:1	0D341151 thru OF305180
1.81:1	0F729151 and Above
1.84:1	0D342272 thru OF386000
1.94:1	0F729751 and Above
1.98:1	0D350952 thru OF624917
2.0:1	0L100009 and Above

NOTICE
Refer to Appropriate Engine Service Manual for Engine Repair

Table of Contents

IMPORTANT INFORMATION

Section 1A - General Information

How To Use This Manual	1A-2	Decal Application	1A-5
Page Numbering	1A-2	Decal Removal	1A-5
Introduction	1A-3	Instructions for "Wet" Application ...	1A-5
Special Product Information	1A-3	Painting Procedures	1A-7
Directional References	1A-3	Cleaning & Painting Aluminum	
Propeller Rotation	1A-4	Propellers & Gear Housings	1A-7
Serial Number Locations and			
Engine Designation Decal	1A-4		
Sterndrive Unit Serial Number			
Location	1A-5		

Section 1B - Maintenance

Trim Pump Specifications	5A-2	Checking Lubricant for Water	1B-10
Valve Pressure Specifications	5A-2	Changing Lubricant	1B-12
Maintenance Schedules	1B-2	General Maintenance	1B-14
Maintenance Intervals	1B-2	Maintaining Power Package	
Gas Sterndrive	1B-2	Exterior Surfaces	1B-14
Routine Maintenance *	1B-2	Steering Head and Remote	
Scheduled Maintenance *	1B-3	Control Maintenance	1B-14
Quicksilver Maintenance Products	1B-4	Checking Quicksilver MerCathode	
Lubricating Shift Cable Pivot Points	1B-4	System	1B-14
Lubricating Propeller Shaft	1B-4	Maintaining Anodic Trim Tab or	
Lubricating Steering System	1B-5	Plate	1B-14
Power Steering Models	1B-5	Checking Optional Quicksilver	
Manual Steering Models	1B-5	Anti-Corrosion Anode Kit	1B-14
Lubricating Tie Bar Pivot Points	1B-6	Boat Bottom Care	1B-15
Models With Control Valve Mounted		Antifouling Paint	1B-15
On Starboard Transom Assembly ..	1B-6	Maintaining Ground Circuit	
Models With Control Valve Mounted		Continuity	1B-15
On Port Transom Assembly	1B-6	Power Package Layout (Out of	
Lubricating Transom and Gimbal		Season Storage)	1B-16
Assembly ,Hinge Pins and Gimbal Bearing	1B-7	Engine	1B-16
Checking and Adding Sterndrive Oil ...	1B-8	Sterndrive	1B-16
Models Without Drive Unit Gear		Power Package Recommissioning	1B-18
Lube Monitor	1B-8	Engine	1B-18
Models With Gear Lube Monitor	1B-9	Sterndrive	1B-18

Section 1C - Troubleshooting

Troubleshooting	1C-3		
Sterndrive Unit Troubleshooting	1C-3	Power Trim Pump Motor Runs In The IN/DOWN Direction, But Not In The OUT/UP Direction-Both Trim And Trailer Switches Inoperative-	1C-14
Sterndrive Unit Will Not Slide Into Bell Housing	1C-3	Power Trim Pump Motor Runs In The IN/DOWN Direction, But Not In The OUT/UP Direction-Both Trim And Trailer Switches Inoperative	1C-14
Drive Unit Does Not Shift Into Gear; Remote Control Shift Handle Moves Drive Unit Does Not Shift Into Gear; Remote Control Shift Handle Does Not Move	1C-3	Trim Control OUT/UP Trim Switch Inoperative	1C-15
Drive Unit Shifts Hard	1C-4	Trim Control Trailer Switch Inoperative	1C-15
Drive Unit In Gear, Will Not Shift Out Of Gear	1C-4	Trim System Functions While Unattended	1C-15
Gear Housing Noise	1C-4	Power Trim System Wiring Diagram ...	1C-16
Drive Shaft Housing Noise	1C-5	Power Trim Hydraulic System	1C-17
Drive Shaft Housing Noise (Continued)	1C-6	Drive Unit Cannot Be Trimmed OUT/UP Or Trims Slowly Or With Jerky Movements	1C-17
Drive Shaft Housing Noise (Continued)	1C-7	Drive Unit Will Not Stay In Trimmed OUT/UP Position	1C-17
Performance Troubleshooting	1C-8	Sterndrive Unit Trails OUT/UP On Deceleration Or When Shifting Into Reverse	1C-17
Low WOT Engine Rpm	1C-8	Oil Foams Out Of Pump Fill/Vent Screw	1C-18
High WOT Engine Rpm	1C-8	Sterndrive Unit Cannot Be Lowered From UP Position Or Lowers With Jerky Movements	1C-18
Propeller Ventilating/Cavitating	1C-8	Sterndrive Unit Will Not Stay In Full UP Position For Extended Periods	1C-18
Poor Boat Performance And/Or Poor Maneuverability-Bow Too Low Poor Boat Performance And/Or Poor Maneuverability-Bow Too High	1C-8	Sterndrive Will Not Stay In The Trimmed OUT/UP Position When Underway	1C-19
Power Steering	1C-9	Sterndrive Unit Trails OUT/UP On Deceleration Or When Shifting Into Reverse	1C-19
Hard Steering - Helm And Cable	1C-9	Oil Foams Out Of Pump Fill/Vent Screw	1C-19
Hard Steering (Engine Running) - Power Steering System	1C-10	Trim Motor Runs But Does Not Pump Oil	1C-19
Power Steering System External Fluid Leaks	1C-10	Trim Pump Runs Slowly In Both Directions	1C-19
Compact Hydraulic Steering	1C-11	Trim Pump Runs Slowly With A Laboring Sound	1C-19
Important Information	1C-11		
Helm Becomes Jammed During Filling	1C-11		
System Difficult To Fill	1C-11		
Steering Hard To Turn	1C-11		
Helm Unit Bumpy - Requires Too Many Turns	1C-11		
Power Trim Electrical System	1C-12		
Power Trim Pump Motor Will Not Run In The OUT/UP Or IN/DOWN Direction	1C-12		
Power Trim Pump Motor Will Not Run In The OUT/UP Or IN/DOWN Direction	1C-13		
Power Trim Pump Motor Runs In The OUT/UP Direction, But Not In The IN/DOWN Direction	1C-13		
Power Trim Pump Motor Runs In The OUT/UP Direction, But Not In The IN/DOWN Direction	1C-14		

Section 1C - Troubleshooting (continued)

<p>Power Trim Hydraulic Schematic 1C-20</p> <p>Auto Trim II Electrical System 1C-21</p> <p style="padding-left: 20px;">Pump Motor Will Not Run UP Or DOWN In Either Manual Or Auto Mode 1C-21</p> <p style="padding-left: 20px;">Pump Motor Will Not Stop Running Down In Auto Mode 1C-22</p> <p style="padding-left: 20px;">Pump Motor Will Not Run Up Or Down In Auto Mode 1C-22</p> <p style="padding-left: 20px;">Trim System Completely Inoperative In Manual Mode 1C-23</p> <p style="padding-left: 20px;">Pump Motor Will Run UP, But Not Down In Both Manual And Auto Modes 1C-23</p> <p style="padding-left: 20px;">Pump Motor Runs Down, But Not UP In Both The Manual And Auto Modes 1C-23</p> <p style="padding-left: 20px;">Pump Motor Will Run Down, But Not UP In Auto Mode 1C-24</p> <p style="padding-left: 20px;">Pump Motor Will Run UP, But Not DOWN In Auto Mode 1C-24</p> <p style="padding-left: 20px;">Trim DOWN/IN Switch Inoperative In Manual Trim Control 1C-24</p> <p style="padding-left: 20px;">Trim UP/OUT Switch Inoperative In Manual Trim Control 1C-25</p> <p style="padding-left: 20px;">Trailer Switch In Manual, Trim Control Inoperative 1C-25</p> <p style="padding-left: 20px;">Boat Is On Plane Well Before Drive Unit Begins To Trim Out 1C-25</p> <p style="padding-left: 20px;">Boat Is Not On Plane Before Drive Unit Begins To Trim Out 1C-25</p>	<p>Auto Trim II System Wiring Diagram . . . 1C-26</p> <p>Corrosion Protection 1C-26</p> <p style="padding-left: 20px;">Corrosion On Underwater Parts, Without MerCathode Or Impressed Current Protection 1C-27</p> <p style="padding-left: 20px;">Corrosion On Underwater Parts, With MerCathode Or Impressed Current Protection 1C-28</p> <p style="padding-left: 20px;">Corrosion On Underwater Parts, With MerCathode Or Impressed Current Protection 1C-30</p> <p style="padding-left: 20px;">Testing Procedure for Corrosion Protection 1C-31</p> <p style="padding-left: 20px;">MerCathode Controller 1C-32</p> <p>Shift System Troubleshooting 1C-33</p> <p style="padding-left: 20px;">Troubleshooting Shift Problems 1C-34</p> <p style="padding-left: 20px;">Checking for Excessive Play 1C-36</p> <p style="padding-left: 20px;">Isolating Excessive Play 1C-40</p> <p style="padding-left: 20px;">Checking Remote Control Shift Cable Output 1C-42</p> <p style="padding-left: 20px;">Checking Cutout Switch Timing (Models With Roller Type Switch) . . 1C-43</p> <p style="padding-left: 20px;">Checking Cutout Switch Timing (Models With Plunger Type Switch) . 1C-45</p> <p style="padding-left: 20px;">Checking Operation 1C-47</p>
---	---

REMOVAL, INSTALLATION AND ADJUSTMENT

Section 2A - All Models

<p>Sterndrive Unit Removal 2A-2</p> <p>Sterndrive Unit Installation 2A-6</p> <p>Remote Control Shift Cable Adjustment (Drive Unit Installed) 2A-13</p> <p style="padding-left: 20px;">Troubleshooting Shift Problems 2A-22</p> <p style="padding-left: 20px;">Propeller Installation 2A-23</p> <p>Transom Assembly Removal 2A-25</p> <p style="padding-left: 20px;">Power Steering Models 2A-25</p> <p style="padding-left: 20px;">Manual Steering Models 2A-26</p> <p>Transom Assembly Installation 2A-31</p> <p style="padding-left: 20px;">Power Steering Models 2A-36</p> <p style="padding-left: 20px;">Manual Steering Models 2A-38</p>	
---	--

STERNDRIVE UNIT

Section 3A - Drive Shaft Housing

Specifications	3A-2	U-joint Assembly - Inspection and Disassembly	3A-15
Torque Specifications	3A-2	Oil Seal Carrier Subassembly	3A-17
Upper Drive Shaft Bearing Preload	3A-2	Pinion Gear Subassembly	3A-18
U-joint Bearing Preload	3A-2	U-joint Subassembly	3A-21
Gear Shimming Specifications	3A-2	U-joint Assembly	3A-24
Lubricants/Sealers/Adhesives	3A-3	Top Cover Subassembly	3A-26
Special Tools	3A-3	Upper Driven Gear Subassembly	3A-29
Drive Shaft Housing Exploded Parts View	3A-4	Drive Shaft Housing Reassembly	3A-33
U-joint and Driven Gear Components	3A-4	Drive Shaft Housing Inspection	3A-33
Drive Shaft Components	3A-6	Installation	3A-33
Special Information	3A-7	Assembly and Checking Driven Gear Location	3A-35
Top Cover Bearing Cup	3A-7	Adjusting Gear Location	3A-38
Universal Joint Bearing Set	3A-7	Seal Installation	3A-39
Drive Shaft Housing/Gear Housing Separation	3A-7	Checking and Adjusting Drive Gear Location	3A-43
Drive Shaft Housing and Component Disassembly	3A-9	Final Reassembly	3A-45
Drive Unit Gear Ratio Identification	3A-9	Joining Drive Shaft Housing/Gear Housing	3A-47
Drive Shaft Housing Cleaning and Inspection	3A-15		

Section 3B - Gear Housing Standard Rotation

Standard Rotation Gear Housing Specifications	3B-2	Shift Spool Assembly	3B-44
Torque Specifications	3B-2	Propeller Shaft Assembly	3B-45
Shimming Specifications	3B-2	Shift Shaft Assembly	3B-47
Lubricants / Sealers / Adhesives	3B-2	Pinion Bearing	3B-50
Special Tools	3B-3	Gear Housing Reassembly	3B-51
Special Tools (continued)	3B-4	Gear Housing Inspection	3B-51
Standard Rotation Gear Housing Exploded Parts View	3B-6	Pinion Bearing	3B-51
Drive Shaft Components	3B-6	Forward Gear Bearing Cup	3B-52
Propeller Shaft Components	3B-8	Shift Shaft Assembly	3B-53
Special Information	3B-10	Propeller Shaft Assembly	3B-55
Shift Spool Assembly	3B-10	Drive Shaft and Pinion Gear	3B-57
Forward Gear Bearing Bore	3B-11	Drive Shaft - Bearing Preload Tool	3B-60
Pre-Disassembly Inspection	3B-12	Pinion Gear Location	3B-61
Propeller	3B-12	Bearing Carrier Assembly	3B-62
Propeller Shaft	3B-12	Forward Gear Backlash	3B-65
Drive Shaft Housing/Gear Housing Separation	3B-13	Reverse Gear Backlash	3B-67
Separation	3B-13	Forward and/or Reverse Gear Backlash Adjustment	3B-69
Gear Housing and Component Disassembly	3B-15	Drive Shaft - Bearing Preload Tool	3B-69
Water Pump Subassembly	3B-15	Bearing Carrier Assembly	3B-70
Oil Seal Carrier Subassembly	3B-18	Final Installation	3B-70
Bearing Carrier Subassembly	3B-21	Oil Seal Carrier Assembly	3B-74
Drive Shaft Assembly	3B-34	Installation	3B-74
Propeller Shaft Assembly and Forward Gear Bearing Cup	3B-37	Water Pump Assembly	3B-75
Forward Gear Assembly	3B-41	Installation	3B-75
		Joining Drive Shaft Housing/Gear Housing	3B-78

Section 3C - Gear Housing (Counter Rotation)

Specifications	3C-2	Propeller Shaft Assembly	3C-47
Torque Specifications	3C-2	Reverse Gear Assembly	3C-52
Shimming Specifications	3C-2	Shift Spool Assembly	3C-54
Lubricants/Sealers/Adhesives	3C-2	Reverse Gear Bearing Adaptor Assembly	3C-56
Special Tools	3C-2	Shift Shaft Assembly	3C-58
Special Tools (continued)	3C-4	Pinion Bearing	3C-60
Counter-Rotation Gear Housing Exploded Parts View	3C-6	Gear Housing Reassembly	3C-62
Drive Shaft Components	3C-6	Gear Housing Inspection	3C-62
Propeller Shaft Components	3C-8	Pinion Bearing Installation	3C-62
Special Information	3C-10	Shift Shaft Assembly Installation	3C-63
Shift Spool Assembly	3C-10	Reverse Gear Bearing Adaptor Assembly Installation	3C-65
Propeller Shaft	3C-10	Gear Location/Backlashes Checking and Adjustment	3C-69
Forward Gear Bearing Bore	3C-11	Reverse Gear	3C-69
Bearing Carrier	3C-11	Drive Shaft and Pinion Gear	3C-71
Thrust Collar	3C-12	Drive Shaft - Bearing Preload Tool	3C-74
Reverse Gear Bearing Adaptor	3C-12	Pinion Gear Location	3C-76
Forward Gear Bearing Adaptor	3C-13	Reverse Gear Backlash	3C-78
Pre-Disassembly Inspection	3C-14	Forward Gear Backlash	3C-80
Propeller	3C-14	Drive Shaft - Bearing Preload Tool	3C-88
Propeller Shaft	3C-14	Propeller Shaft Assembly	3C-88
Drive Shaft Housing/Gear Housing Separation	3C-15	Component Reassembly	3C-88
Gear Housing and Component Disassembly	3C-17	Installation	3C-91
Water Pump Assembly	3C-17	Drive Shaft and Pinion Gear	3C-95
Oil Seal Carrier Assembly	3C-20	Final Installation	3C-95
Bearing Carrier Assembly	3C-23	Bearing Carrier Assembly	3C-98
Forward Gear Bearing and Adaptor	3C-27	Final Installation	3C-98
Bearing Carrier Disassembly And Inspection	3C-35	Oil Seal Carrier Assembly	3C-110
Bearing Carrier Reassembly	3C-37	Installation	3C-110
Forward Gear Bearing Adaptor Assembly	3C-39	Water Pump Assembly	3C-111
Drive Shaft Assembly	3C-42	Installation	3C-111
		Joining Drive Shaft Housing/Gear Housing	3C-114

TRANSOM ASSEMBLY

Section 4A - Service Procedures Requiring Minor Disassembly

Specifications	4A-2	Shift Cable	4A-19
Torque Specifications	4A-2	Removal	4A-19
Lubricants/Sealers/Adhesives	4A-2	Inspection	4A-22
Special Tools	4A-2	Installation	4A-23
Special Information	4A-3	Remote Control Shift Cable Adjustment (Drive Unit Installed)	4A-28
Trim Limit Switch	4A-3	Exhaust Bellows	4A-38
Trim Position Sender	4A-3	Removal	4A-38
Trim Limit Switch and Trim Position Sender	4A-4	Cleaning And Inspection	4A-39
Removal	4A-4	Installation	4A-39
Installation	4A-7	Gear Lube Monitor Kit System Components - Replacement	4A-42
Trim Position Sender Adjustment	4A-12	Monitor To Thru-Bulkhead Fitting Hose:	4A-42
Trim Limit Switch Adjustment	4A-13	Thru-bulkhead To Bell Housing Gear Lube Monitor Hose	4A-46
Gimbal Bearing	4A-15	Bell Housing To Driveshaft Housing Anti-Dribble Valves	4A-48
Inspection	4A-15	Crimp Clamp Tool	4A-50
Removal	4A-15		
Installation	4A-17		

Section 4B - Service Procedures Requiring Major Disassembly

Transom Assembly Specifications	4B-2	Shift Cable Bellows Removal	4B-29
Torque Specifications	4B-2	Bushings And Upper Seal Removal .	4B-30
Special Tools	4B-2	Component Servicing	4B-32
Lubricants / Sealers / Adhesives	4B-3	Bell Housing Disassembly	4B-32
Special Information	4B-4	Bell Housing Reassembly	4B-37
Trim Limit Switch	4B-4	Gasket And O-Ring	4B-41
Trim Position Sender	4B-4	Speedometer Tubing And Water	
Shift Cable	4B-4	Hose	4B-42
Gear Lube Monitor Kit Access		Reassembly	4B-45
Plug Locations	4B-5	Gimbal Ring Bushing Installation ...	4B-45
Alpha One Transom Assembly		Oil Seal Installation	4B-47
Exploded View	4B-7	Exhaust Bellows Installation	4B-49
Bell Housing Components	4B-7	Trim Position Sender and Trim Limit	
Gimbal Housing Components	4B-9	Switch Wire Installation	4B-50
Inner Transom Plate Components ..	4B-11	Gimbal Ring, Swivel Shaft and	
Gimbal Ring and Steering Lever		Steering Lever Installation	4B-51
Components	4B-13	Shift Cable Bellows Installation	4B-59
Component Disassembly	4B-15	Bell Housing Installation	4B-61
Bell Housing Removal	4B-15	Trim Limit Switch Installation	4B-69
Trim Position Sender and Trim		Trim Position Sender Installation	4B-70
Limit Switch Wire Removal	4B-21	ALPHA ONE (GENERATION II)	
Gimbal Ring, Swivel Shaft and		ACCESS PLUG	4B-71
Steering Lever Removal	4B-21	– DRILLING TEMPLATE –	4B-71
Gimbal Housing Servicing	4B-28		
U-Joint Bellows Removal	4B-28		

POWER TRIM

Section 5A - Olidyne Trim Pump

Trim Pump Specifications	5A-2	Trim Pump Removal	5A-25
Valve Pressure Specifications	5A-2	Hydraulic Repair	5A-27
Electrical Specification	5A-2	Disassembly	5A-27
Torque Specification	5A-2	Filter Replacement	5A-29
Special Tools	5A-2	UP Pressure Relief Valve	
Lubricants/Adhesives/Sealers	5A-2	Replacement	5A-30
Trim Pump Exploded View	5A-4	DOWN Pressure Relief Valve	
Olidyne Trim Pump	5A-4	Replacement	5A-32
Maintaining Power Trim Pump Oil		Thermal Relief Valve Replacement ..	5A-34
Level	5A-6	Pump Replacement	5A-34
Air Bleeding Power Trim System	5A-7	Adapter Replacement	5A-36
Bleeding OUT/UP Trim Circuit	5A-7	Adapter Repair	5A-38
Bleeding IN/DOWN Trim Circuit	5A-8	Pump Shaft Oil Seal Replacement ..	5A-41
Testing Power Trim Pump	5A-9	Motor Repair	5A-43
Test Gauge	5A-9	Disassembly	5A-43
Internal Restriction Test	5A-10	Armature Tests	5A-46
OUT/UP Pressure Test	5A-10	Continuity Test	5A-46
IN/DOWN Pressure Test	5A-12	Test for Shorts	5A-47
Trim Pump Hydraulic System	5A-13	Cleaning Commutator	5A-47
Trim Cylinder Internal Leak Test	5A-14	Field Tests	5A-47
Trim Cylinder Shock Piston Test	5A-15	Test for Open Circuit	5A-47
Motor and Electrical Bench Tests	5A-16	Test for Short in Field	5A-48
110 Amp Fuse Test (Pump in Boat) ..	5A-16	Thermal Switch Continuity Test	5A-49
110 Amp Fuse Test		Brush Replacement	5A-50
(Pump Out of Boat)	5A-17	Reassembly	5A-53
20 Amp Fuse Test	5A-17	Trim Pump Installation	5A-59
Trim Pump Motor Test (In Boat)	5A-18	Trim Pump Wiring Diagrams	5A-60
Trim Pump Motor Test		Model With Three-Button	
(Out of Boat)	5A-20	Trim/Trailer Panel	5A-60
Solenoid Test (Pump In Boat)	5A-22	Model With Trim In Handle and	
Solenoid Test (Pump Out of Boat) ...	5A-24	Trailer Switch Separate	5A-61

Section 5B - Trim Cylinders

Specifications	5B-2
Torque Specifications	5B-2
Special Tools	5B-2
Lubricants/Sealers/Adhesives	5B-2
Trim Cylinder Repair	5B-3
Removal	5B-3
Disassembly	5B-5
Reassembly	5B-9
Installation	5B-15

Section 5C - Dual Power Trim System

Important Information	5C-2	Diode Module Replacement	5C-7
Testing Dual Power Trim System	5C-2	Removal	5C-7
Relay Test	5C-3	Installation	5C-7
Diode Module Test	5C-3	Trim Control Panel Switch(es)	
Trailer Switch Test	5C-4	Replacement	5C-8
Starboard Trim Switch Test	5C-4	Removal	5C-8
Port Trim Switch Test	5C-4	Installation	5C-9
Dual Power Trim System Component		Wiring Diagrams	5C-10
Repair	5C-5	Dual Trim Harnesses	5C-10
Important Information	5C-5	Electrical Box Wiring	5C-11
Relay Replacement	5C-5		

Section 5D - Auto Trim II

Auto Trim II System	5D-2	Auto Trim Limit Adjustment	5D-6
Description	5D-2	Adjusting Sterndrive Unit Trim Angle	5D-7
Auto Trim II Operation	5D-2	Control Module Adjustment	5D-9
Auto Mode Operation	5D-3	Trim Position Indicator Adjustment	5D-10
“Manual” Mode Operation	5D-4	Wiring Diagram	5D-11
Electrical System Overload Protection ..	5D-6		

STEERING SYSTEMS

Section 6A - Power Steering

Trim Pump Specifications	5A-2	Selection	6A-17
Valve Pressure Specifications	5A-2	Removal	6A-18
Specifications	6A-2	Installation	6A-18
Special Tools	6A-2	Installation	6A-20
Lubricants/Adhesives/Sealers	6A-2	Power Steering Pump Lugging Test ..	6A-21
Description	6A-3	Power Steering System Pressure	
Earlier Style Control Valve	6A-3	Test	6A-23
Later Style Control Valve	6A-3	Pump Pressure Test	6A-25
Earlier Model Power Steering System ..	6A-4	Booster Cylinder Test	6A-27
Right Turn	6A-4	Power Steering Component Repair	6A-29
Earlier Model Power Steering System ..	6A-5	Power Steering Unit	6A-29
Left Turn	6A-5	Cable Guide Tube (Early Style Only)	6A-33
Earlier Model Power Steering System ..	6A-6	Control Valve (Early Style Only)	6A-37
Neutral	6A-6	Booster Cylinder (Early Style Only) ..	6A-50
Later Model Power Steering System	6A-7	Power Steering Pump	6A-55
Right Turn	6A-7	Removal	6A-55
Later Model Power Steering System	6A-8	Flow Control Valve Servicing	6A-55
Left Turn	6A-8	Pump Shaft Oil Seal Replacement ..	6A-56
Later Model Power Steering System	6A-9	Disassembly	6A-58
Neutral	6A-9	Cleaning And Inspection	6A-61
Steering Helm and Cable	6A-10	Reassembly	6A-61
Steering Cable Specifications	6A-11	Multiple Sterndrive Steering Tie Bar	
Filling and Air Bleeding Power		Arrangements	6A-67
Steering System	6A-12	Determining Tie Bar Length	6A-67
Balancing Power Steering Control		Selection	6A-68
Valve	6A-13	Installation	6A-69
Steering Cable Selection, Removal			
and Installation	6A-17		

Section 6B - Manual Steering

Specifications	6B-2	Manual Steering Swivel Ring	
Torque Specifications	6B-2	Component Repair	6B-6
Lubricants/Sealers/Adhesives	6B-2	Removal	6B-6
Steering Cable Selection, Removal		Disassembly	6B-7
and Installation	6B-2	Reassembly	6B-7
Selection	6B-2	Installation	6B-9
Removal	6B-4		
Installation	6B-4		

CORROSION PROTECTION

Section 7A - All Models

Specifications	7A-2	Wiring Diagrams	7A-18
Special Tools	7A-2	MerCathode Monitor	7A-18
Lubricants/Sealers/Adhesives	7A-2	MerCathode Controller	7A-19
Continuity Circuit	7A-2	Quicksilver Isolator	7A-20
Anodic Block	7A-5	Corrosion Protection Testing and	
Trim Cylinder Anodes	7A-9	Troubleshooting	7A-20
Anodic Trim Tab or Plate	7A-10	Test Equipment Set-Up	7A-23
Replacement	7A-10	Low Readings	7A-24
Integral MerCathode System	7A-12	Low Readings (continued)	7A-25
Removing Electrode Assembly	7A-12	High Reading	7A-26
Installing Electrode Assembly	7A-13	Normal Reading But Corrosion is	
Connect Electrical Leads to		Evident	7A-26
Controller Assembly	7A-17		

THIS PAGE IS INTENTIONALLY BLANK

IMPORTANT INFORMATION

Section 1A - General Information

**1
A**

Table of Contents

How To Use This Manual	1A-2	Decal Application	1A-5
Page Numbering	1A-2	Decal Removal	1A-5
Introduction	1A-3	Instructions for "Wet" Application ...	1A-5
Special Product Information	1A-3	Painting Procedures	1A-7
Directional References	1A-3	Cleaning & Painting Aluminum	
Propeller Rotation	1A-4	Propellers & Gear Housings	1A-7
Serial Number Locations and			
Engine Designation Decal	1A-4		
Sterndrive Unit Serial Number			
Location	1A-5		

How To Use This Manual

This Manual is divided into sections which represent major components and systems. Some sections are further divided into parts which more fully describe the component. Sections and parts are listed at the front of this manual.

Page Numbering

Two number groups appear at the bottom of each page. Following is an example and description.

Page 1A-2

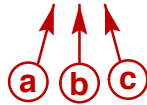

90-17431--4 FEBRUARY 1998

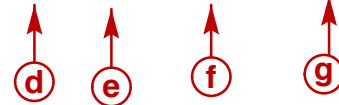

- a**- Section Number
- b**- Section Part
- c**- Page Number
- d**- Manual Part Number
- e**- Revision Number
- f**- Month Printed
- g**- Year Printed

Introduction

This comprehensive overhaul and repair manual is designed as a service guide for the Mercury MerCruiser models previously listed. It provides specific information, including procedures for disassembly, inspection, assembly and adjustment, to enable dealers and service mechanics to repair these products.

Before attempting repairs, it is suggested that the procedure be read to gain knowledge of the methods and tools used and the cautions and warnings required for safety.

Special Product Information

During production of these models, special product improvements and changes have been made to increase product reliability and performance. Such changes to a sterndrive assembly component(s) are covered in the "Special Information" portion of the appropriate sterndrive assembly section. (Refer to the section "Index".) Serial number breaks are provided, where applicable, for ease of identification.

Directional References

Front of boat is bow; rear is stern. Starboard side is right side; port side is left side. In this service manual, all directional references are given as they appear when viewing boat from stern, looking toward bow.

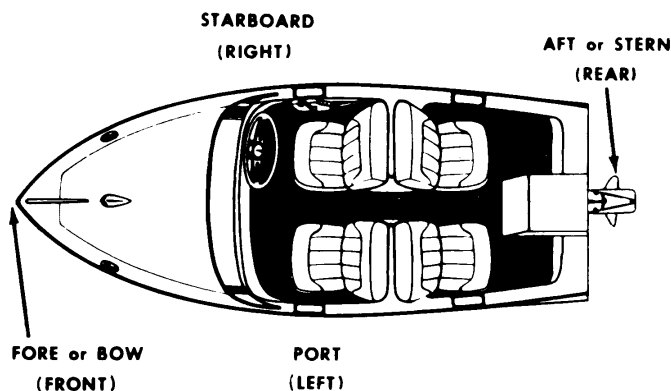

Propeller Rotation

Propeller rotation for sterndrive can be right hand or left hand rotation as viewed from the aft end of the propeller.

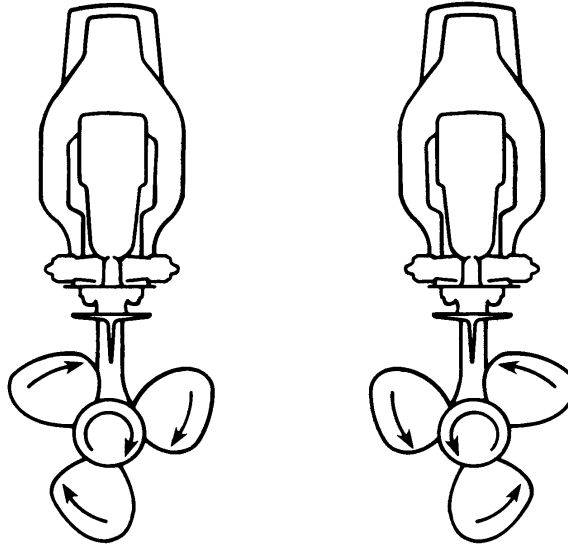

Right Hand Rotation

Left Hand Rotation

Serial Number Locations and Engine Designation Decal

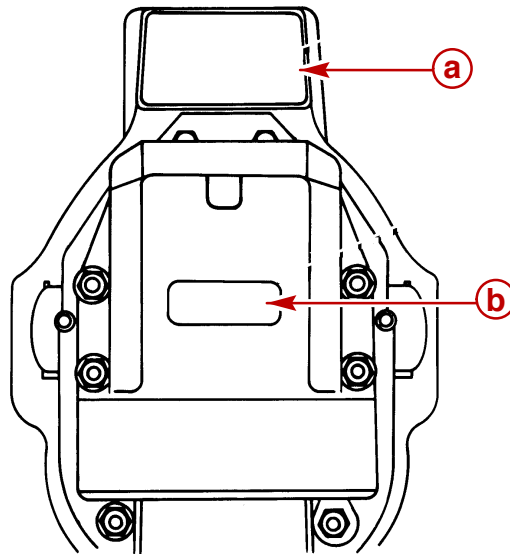

- a** - Transom Assembly Serial Number
- b** - Engine Designation Decal

22031

Sterndrive Unit Serial Number Location

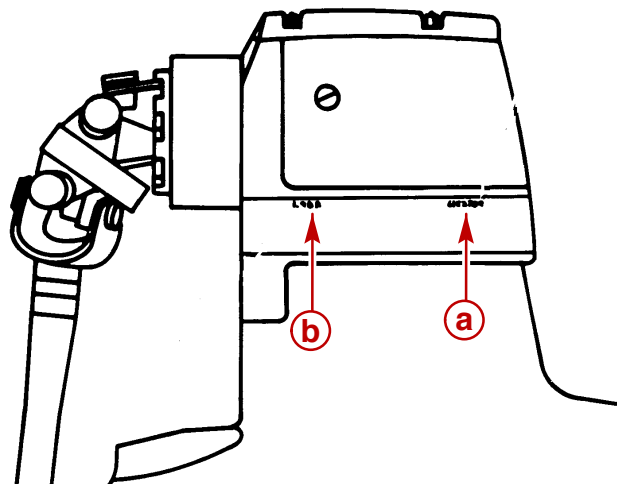

22026

Sterndrive Unit Serial Number Location - Port Decal

(Also Located Under Decal On Housing)

- a** - Sterndrive Unit Serial Number
- b** - Sterndrive Unit Gear Ratio

Decal Application

Decal Removal

1. Mark decal location before removal to assure proper alignment of new decal.
2. Carefully soften decal and decal adhesive with a heat gun or heat blower while removing old decal.
3. Clean decal contact area with a 1:1 mixture of isopropyl alcohol and water.
4. Thoroughly dry decal contact area and check for a completely cleaned surface.

Instructions for “Wet” Application

NOTE: The following decal installation instructions are provided for a “Wet” installation. **All** decals should be applied wet.

TOOLS REQUIRED

1. Plastic Squeegee*
2. Stick Pin
3. Dish Washing **Liquid/Detergent without ammonia**** “Joy” and “Drift” are compatible for this process.

* Automotive Body Filler Squeegee

** Do not use a soap that contains petroleum based solvents.

SERVICE TIP: Placement of decals using the “Wet” application will allow time to position decal. Read entire installation instructions on this technique before proceeding.

TEMPERATURE

IMPORTANT: Installation of vinyl decals should not be attempted while in direct sunlight. Air and surface temperature should be between 60°F (15°C) and 100°F (38°C) for best application.

SURFACE PREPARATION

IMPORTANT: Do not use a soap or any petroleum based solvents to clean application surface.

Clean entire application surface with mild dish washing liquid and water. Rinse surface thoroughly with clean water.

DECAL APPLICATION

1. Mix $\frac{1}{2}$ ounce (16 ml) of dish washing liquid in one gallon (4 l) of cool water to use as wetting solution.

NOTE: Leave protective masking, if present, on the face of decal until final steps of decal installation. This will ensure that the vinyl decal keeps its shape during installation.

2. Place the decal face down on a clean work surface and remove the paper backing from “adhesive side” of decal.
3. Using a spray bottle, flood the entire “adhesive side” of the decal with the pre-mixed wetting solution.
4. Flood area where the decal will be positioned with wetting solution.
5. Position pre-wetted decal on wetted surface and slide into position.
6. Starting at the center of the decal, “lightly” squeegee out the air bubbles and wetting solution with overlapping strokes to the outer edge of the decal. Continue going over the decal surface until all wrinkles are gone and adhesive bonds to the cowl surface.
7. Wipe decal surface with soft paper towel or cloth.
8. **Wait 10 - 15 minutes.**
9. Starting at one corner, “carefully and slowly” pull the masking off the decal surface at a 180° angle.

NOTE: To remove any remaining bubbles, pierce the decal at one end of the bubble with stick pin and press out the entrapped air or wetting solution with your thumb (moving toward the puncture).