

---

# Service Manual Outline

## Section 1 - Important Information

- A - General Information
- B - Maintenance
- C - Troubleshooting

## Section 2 - Removal and Installation

- A - MCM 3.0L (181 CID) - Alpha Drive

## Section 3 - Engine

- A - 3.0L (181 CID)

## Section 4 - Electrical System

- A - Starting System
- B - Ignition System
- C - Charging System
- D - Instrumentation
- E - Wiring Diagrams

## Section 5 - Fuel System

- A - Fuel Pump
- B - MerCarb 2-Barrel

## Section 6 - Cooling System

- A - Seawater Cooled Models
- B - Closed Cooled Models

## Section 7 - Exhaust System

- A - Exhaust Manifolds / Elbows

## Section 8 - Power Steering

- A - Power Steering

Important Information

1

Removal And Installation

2

Engine

3

Electrical System

4

Fuel System

5

Cooling System

6

Exhaust System

7

Power Steering

8

---

## Notice

Throughout this publication, “Dangers”, “Warnings” and “Cautions” (accompanied by the International HAZARD Symbol ) are used to alert the mechanic to special instructions concerning a particular service or operation that may be hazardous if performed incorrectly or carelessly. **OBSERVE THEM CAREFULLY!**

These “Safety Alerts” alone cannot eliminate the hazards that they signal. Strict compliance to these special instructions when performing the service, plus “Common Sense” operation, are major accident prevention measures.

### **DANGER**

**DANGER - Immediate hazards which WILL result in severe personal injury or death.**

### **WARNING**

**WARNING - Hazards or unsafe practices which COULD result in severe personal injury or death.**

### **CAUTION**

**Hazards or unsafe practices which could result in minor personal injury or product or property damage.**

## Notice to Users of This Manual

This service manual has been written and published by the Service Department of Mercury Marine to aid our dealers’ mechanics and company service personnel when servicing the products described herein.

It is assumed that these personnel are familiar with the servicing procedures of these products, or like or similar products manufactured and marketed by Mercury Marine, that they have been trained in the recommended servicing procedures of these products which includes the use of mechanics’ common hand tools and the special Mercury Marine or recommended tools from other suppliers.

We could not possibly know of and advise the service trade of all conceivable procedures by which a service might be performed and of the possible hazards and/or results of each method. We have not undertaken any such wide evaluation. Therefore, anyone who uses a service procedure and/or tool, which is not recommended by the manufacturer, first must completely satisfy himself that neither his nor the products safety will be endangered by the service procedure selected.

All information, illustrations and specifications contained in this manual are based on the latest product information available at the time of publication. As required, revisions to this manual will be sent to all dealers contracted by us to sell and/or service these products.

It should be kept in mind, while working on the product, that the electrical system and ignition system are capable of violent and damaging short circuits or severe electrical shocks. When performing any work where electrical terminals could possibly be grounded or touched by the mechanic, the battery cables should be disconnected at the battery.

Any time the intake or exhaust openings are exposed during service they should be covered to protect against accidental entrance of foreign material which could enter the cylinders and cause extensive internal damage when the engine is started.

---

It is important to note, during any maintenance procedure replacement fasteners must have the same measurements and strength as those removed. Numbers on the heads of the metric bolts and on the surfaces of metric nuts indicate their strength. American bolts use radial lines for this purpose, while most American nuts do not have strength markings. Mismatched or incorrect fasteners can result in damage or malfunction, or possibly personal injury. Therefore, fasteners removed should be saved for reuse in the same locations whenever possible. Where the fasteners are not satisfactory for re-use, care should be taken to select a replacement that matches the original.

We reserve the right to make changes to this manual without prior notification.

Refer to dealer service bulletins for other pertinent information concerning the products described in this manual.

## Engine Mechanical Components

Many of the engine mechanical components are designed for marine applications. Unlike automotive engines, marine engines are subjected to extended periods of heavy load and wide-open-throttle operation and, therefore, require heavy-duty components. Special marine engine parts have design and manufacturing specifications which are required to provide long life and dependable performance. Marine engine parts also must be able to resist the corrosive action of salt or brackish water that will rust or corrode standard automotive parts within a short period of time.

Failure to use recommended Quicksilver service replacement parts can result in poor engine performance and/or durability, rapid corrosion of parts subjected to salt water and possibly complete failure of the engine.

Use of parts other than recommended service replacement parts, will void the warranty on those parts which are damaged as a result of the use of other than recommended replacement parts.

## Replacement Parts

### **WARNING**

**Electrical, ignition and fuel system components on MerCruiser Engines and Stern Drives are designed and manufactured to comply with U.S. Coast Guard Rules and Regulations to minimize risks of fire or explosion.**

**Use of replacement electrical, ignition or fuel system components, which do not comply to these rules and regulations, could result in a fire or explosion hazard and should be avoided.**

**When servicing the electrical, ignition and fuel systems, it is extremely important that all components are properly installed and tightened. If not, any electrical or ignition component opening would permit sparks to ignite fuel vapors from fuel system leaks, if they existed.**

## Models Covered in This Manual

Model	Serial Number	Model Year
MCM 3.0L Alpha	OL010042 and Above	1998 -

---

**THIS PAGE IS INTENTIONALLY BLANK**

# IMPORTANT INFORMATION

## Section 1A - General Information

**1  
A**

### Table of Contents

Table of Contents .....	1A-1	Propeller Information .....	1A-5
Introduction .....	1A-2	Water Testing New Engines .....	1A-6
How to Use This Manual .....	1A-2	Boat and Engine Performance .....	1A-6
Page Numbering .....	1A-2	Boat Bottom .....	1A-6
How to Read a Parts Manual .....	1A-3	Marine Fouling .....	1A-8
Directional References .....	1A-4	Weight Distribution .....	1A-9
Engine Rotation .....	1A-4	Water in Boat .....	1A-9
Engine Serial Number Locations .....	1A-5	Elevation and Climate .....	1A-9

# Introduction

This comprehensive overhaul and repair manual is designed as a service guide for the models previously listed. It provides specific information, including procedures for disassembly, inspection, assembly and adjustment to enable dealers and service mechanics to repair and tune these engines.

Before attempting repairs or tune-up, it is suggested that the procedure first be read through to gain knowledge of the methods and tools used and the cautions and warnings required for safety.

## How to Use This Manual

This manual is divided into sections which represent major components and systems.

Some sections are further divided into parts which more fully describe the component.

Sections and section parts are listed on the "Service Manual Outline" page following "V-8 Models Covered in This Manual" page.

## Page Numbering

Two number groups appear at the bottom of each page. Following is an example and description.

---

Page 1A-2

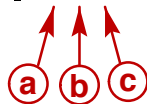

---

90-17431--4 FEBRUARY 1998

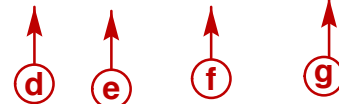

- a** - Section Number
- b** - Section Part
- c** - Page Number
- d** - Manual Part Number
- e** - Revision Number
- f** - Month Printed
- g** - Year Printed

# How to Read a Parts Manual

## POWER STEERING PUMP ASSEMBLY

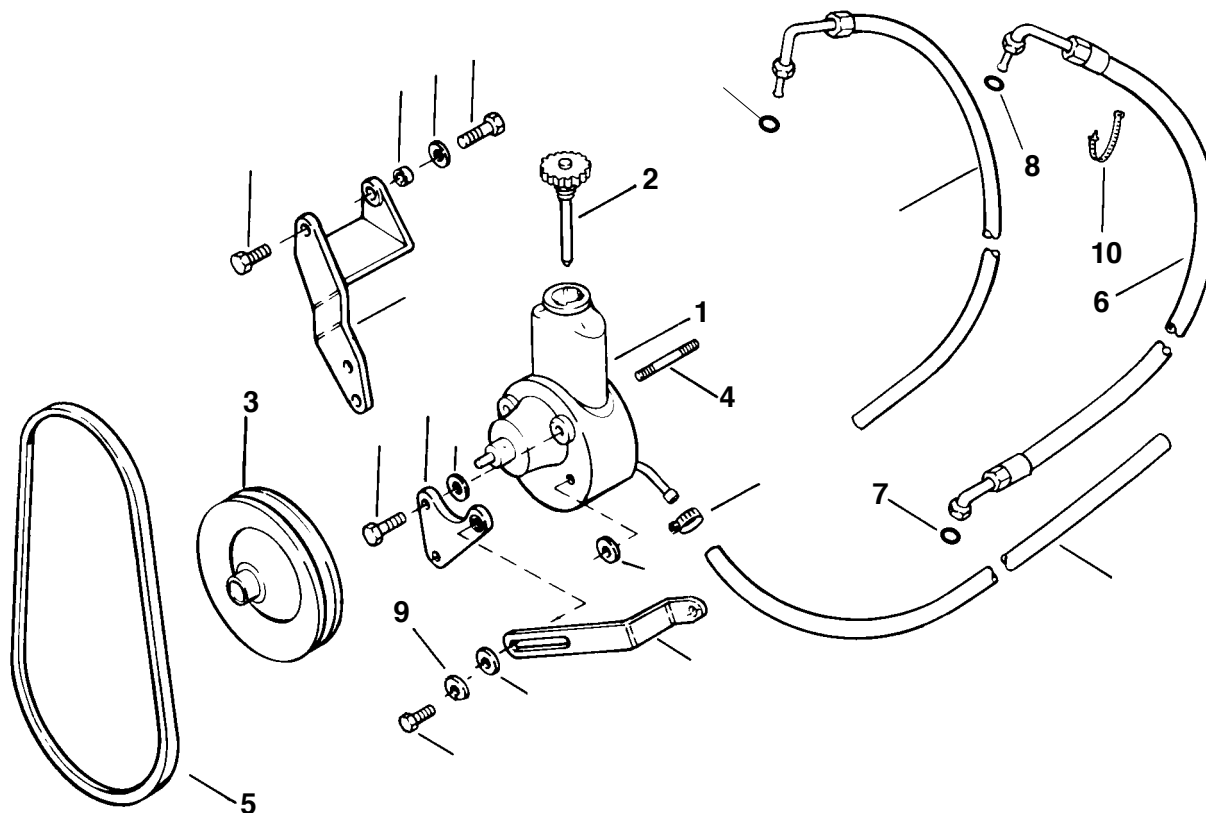

REF. NO.	PART NO.	SYM.	QTY.	DESCRIPTION
1	90507A12		1	PUMP ASSEMBLY–Power Steering
2	36- 95805		1	CAP
3	73873A1		1	PULLEY
4	16- 41877		1	STUD
5	57- 65607T		1	V-BELT
6	32- 806684		1	HOSE–Pressure <b>(FITTINGS ON BOTH ENDS)</b>
7	25- 89879		1	O-RING
8	25- 806232		1	O-RING
9	13- 35048		1	LOCKWASHER (3/8 in.)
10	61990		1	CABLE TIE

**REF. NO. :** Number shown next to part on exploded view

**PART NO. :** Mercury Part Number for ordering. If NSS (not sold separately) sometimes GM part number will be given in description column.

**QTY. :** The quantity that must be ordered.

**DESCRIPTION :** Description of part, what parts are included with a part (all indented items come with the main item above the indented parts), serial number information, and special information.

## Directional References

Front of boat is bow; rear is stern. Starboard side is right side; port side is left side. In this maintenance manual, all directional references are given as they appear when viewing boat from stern looking toward bow.

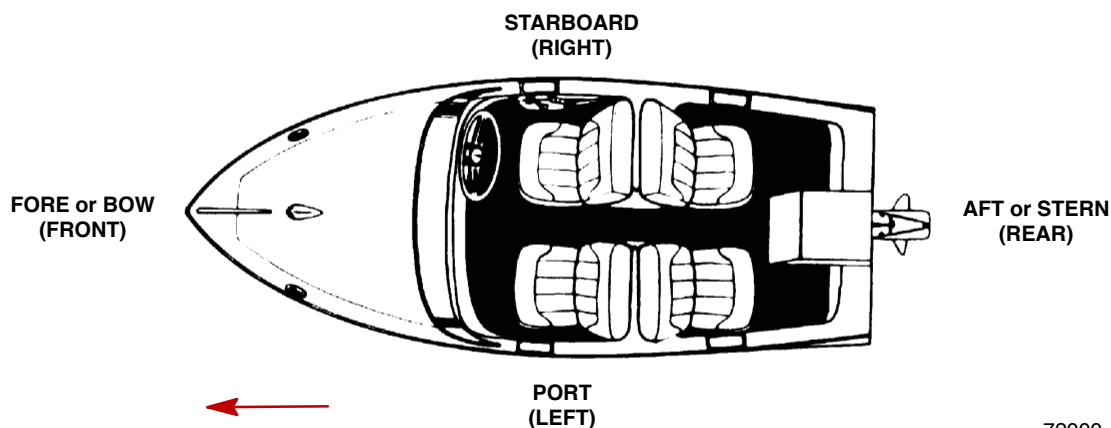

72000

## Engine Rotation

Engine rotation is determined by observing flywheel rotation from the rear (stern end) of the engine looking forward (toward water pump end). Propeller rotation is not necessarily the same as engine rotation. When ordering replacement engine, short blocks or parts for engine, be certain to check engine rotation. Do not rely on propeller rotation in determining engine rotation.

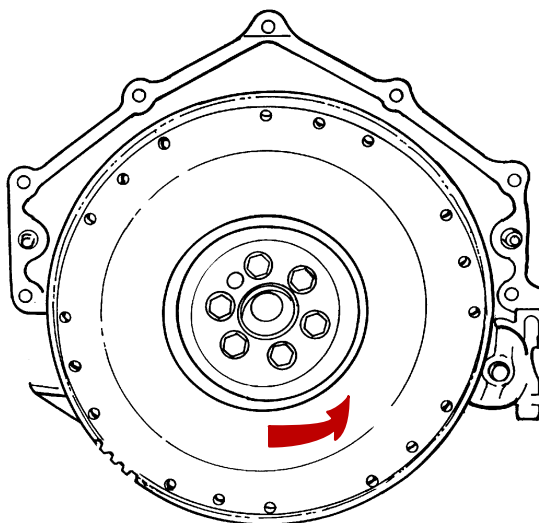

72001

### Standard Left Hand Rotation



## Engine Serial Number Locations

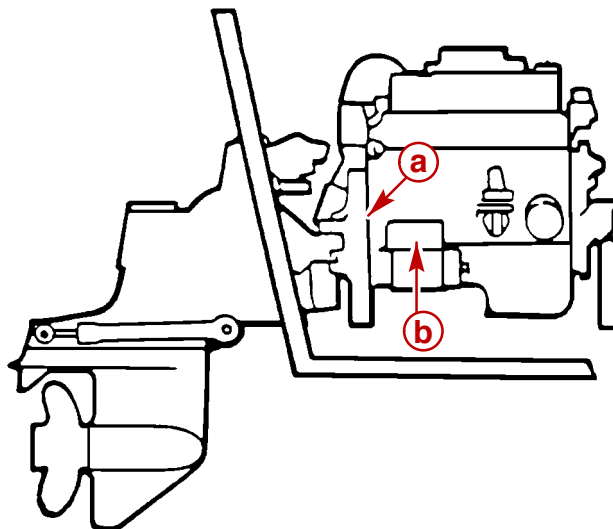

71559

- a** - Serial Number Plate
- b** - Starter Motor

## Propeller Information

Refer to the “Propeller” section in appropriate MerCruiser Sterndrive Service Manual, or order publication 90-86144, “What You Should Know About Quicksilver Propellers.”

Changing diameter, pitch or coupling of a propeller will affect engine rpm and boat performance. The blade configuration also will affect performance. Two like propellers, same pitch and diameter, from two different manufacturers also will perform differently.

It is the responsibility of the boat manufacturer and/or selling dealer to equip the boat with the correct propeller to allow the engine to operate within its specified rpm range at wide-open-throttle (W.O.T.).

Because of the many variables of boat design and operation, only testing will determine the best propeller for the particular application.

To test for correct propeller, operate boat (with an average load onboard) at W.O.T. and check rpm with an accurate tachometer. Engine rpm should be near top of the specified range so that, under heavy load, engine speed will not fall below specifications.

If engine exceeds the specified rpm, an increase in pitch and/or diameter is required.

If engine is below rated rpm, a decrease in pitch and/or diameter is required.

Normally, a change of approximately 400 rpm will be achieved for each single pitch change of a propeller.

### **CAUTION**

**If a propeller is installed that does not allow engine rpm to reach the specified full-throttle rpm range, the engine will “labor” and will not produce full power. Operation under this condition will cause excessive fuel consumption, engine overheating and possible piston damage (due to detonation). On the other hand, installation of a propeller that allows engine to run above the specified rpm limit will cause excessive wear on internal engine parts which will lead to premature engine failure.**

## Water Testing New Engines

Use care during the first 20 hours of operation on new MerCruiser engines or possible engine failure may occur. If a new engine has to be water-tested at full throttle before the break-in period is complete, follow this procedure.

1. Start engine and run at idle rpm until normal operating temperature is reached.
2. Run boat up on plane.
3. Advance engine rpm (in 200 rpm increments) until engine reaches its maximum rated rpm.

**IMPORTANT: Do not run at maximum rpm for more than 2 minutes.**

## Boat and Engine Performance

### Boat Bottom

For maximum speed, a boat bottom should be as flat as possible in a fore-aft direction (longitudinally) for approximately the last 5 ft (1.5 m).

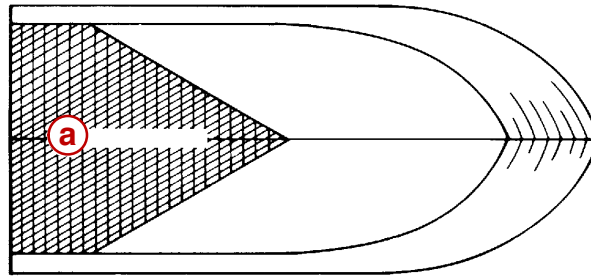

72002

**a** - Critical Bottom Area

For best speed and minimum spray, the corner between the bottom and the transom should be sharp.

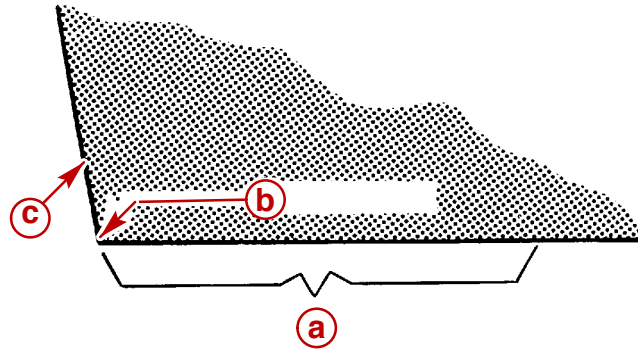

72003

- a** - Bottom
- b** - Corner
- c** - Transom

The bottom is referred to as having a “hook” if it is concave in the fore-and-aft direction. A hook causes more lift on the bottom near the transom and forces the bow to drop. This increases wetted surface and reduces boat speed. A hook, however, aids in planing and reduces any porpoising (rhythmical bouncing) tendency. A slight hook is often built in by the manufacturer. A hook also can be caused by incorrect trailering or storing the boat with support directly under the transom.

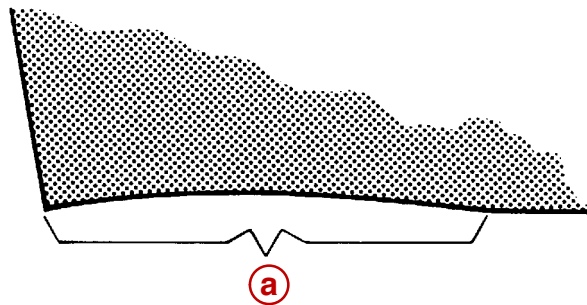

72004

- a** - Hook

A “rocker” is the reverse of a hook. The bottom is convex or bulged in the fore-and-aft direction. It can cause the boat to porpoise.

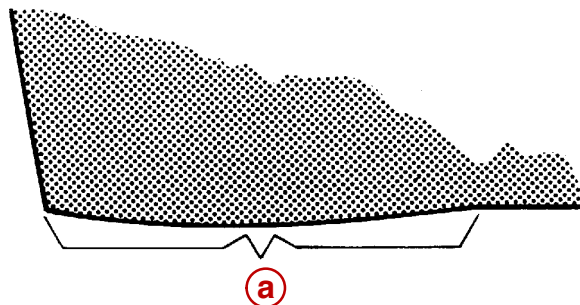

72005

- a** - Rocker

Any hook, rocker or surface roughness on the bottom, particularly in the all-important center-aft portion will have a negative effect on speed, often several miles per hour on a fast boat.

## Marine Fouling

Fouling is an unwanted build-up (usually animal-vegetable-derived) occurring on the boat's bottom and drive unit. Fouling adds up to drag, which reduces boat performance. In fresh water, fouling results from dirt, vegetable matter, algae or slime, chemicals, minerals and other pollutants. In salt water, barnacles, moss and other marine growth often produce dramatic build-up of material quickly. Therefore, it is important to keep the hull as clean as possible in all water conditions to maximize boat performance.

Antifouling paint, if required, may be applied to boat hull observing the following precautions.

**IMPORTANT: DO NOT** paint anodes or MerCathode System reference electrode and anode, as this will render them ineffective as galvanic corrosion inhibitors.

### **⚠ CAUTION**

**Avoid corrosion damage. Do not apply antifouling paint to MerCruiser drive unit or transom assembly.**

**IMPORTANT:** If antifouling protection is required, Tri-Butyl-Tin-Adipate (TBTA) base antifouling paints are recommended on MerCruiser boating applications. In areas where Tri-Butyl-Tin-Adipate base paints are prohibited by law, copper base paints can be used on boat hull and boat transom. Corrosion damage that results from the improper application of antifouling paint will not be covered by the limited warranty. Observe the following:

**Avoid an electrical interconnection between the MerCruiser Product, Anodic Blocks, or MerCathode System and the paint by allowing a minimum of 1 in. (26mm) UNPAINTED area on transom of the boat around these items.**

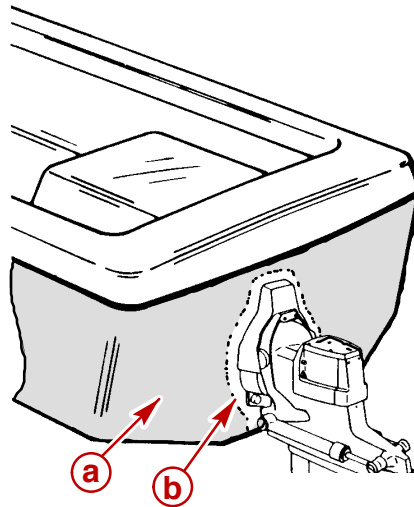

71176

- a** - Antifouling Paint
- b** - MINIMUM 1 inch (26 mm) Unpainted Area

## Weight Distribution

Weight distribution is extremely important; it affects a boat's running angle or attitude. For best top speed, all movable weight - cargo and passengers - should be as far aft as possible to allow the bow to come up to a more efficient angle (3 to 5 degrees). On the negative side of this approach is the problem that, as weight is moved aft, some boats will begin an unacceptable porpoise.

Secondly, as weight is moved aft, getting on plane becomes more difficult.

Finally, the ride in choppy water becomes more uncomfortable as the weight goes aft. With these factors in mind, each boater should seek out what weight locations best suit his/her needs.

Weight and passenger loading placed well forward increases the "wetted area" of the boat bottom and, in some cases, virtually destroys the good performance and handling characteristics of the boat. Operation in this configuration can produce an extremely wet ride, from wind-blown spray, and could even be unsafe in certain weather conditions or where bow steering may occur.

Weight distribution is not confined strictly to fore and aft locations, but also applies to lateral weight distribution. Uneven weight concentration to port or starboard of the longitudinal centerline can produce a severe listing attitude that can adversely affect the boat's performance, handling ability and riding comfort. In extreme rough water conditions, the safety of the boat and passengers may be in jeopardy.

## Water in Boat

When a boat loses performance, check bilge for water. Water can add considerable weight to the boat, thereby decreasing the performance and handling.

Make certain that all drain passages are open for complete draining.

## Elevation and Climate

Elevation has a very noticeable effect on the wide-open-throttle power of an engine. Since air (containing oxygen) gets thinner as elevation increases, the engine begins to starve for air. Humidity, barometric pressure and temperature do have a noticeable effect on the density of air. Heat and humidity thin the air. This phenomenon can become particularly apparent when an engine is propped out on a cool dry day in spring and later, on a hot, humid day in August, does not have the same performance.

Although some performance can be regained by dropping to a lower pitch propeller, the basic problem still exists. The propeller is too large in diameter for the reduced power output. A Quicksilver Propeller Repair Station or experienced marine dealer can determine how much diameter to remove from a lower-pitch propeller for specific high-elevation locations. In some cases, installing high altitude gears in the drive unit is possible and very beneficial. Weather conditions may effect the power output of internal combustion engines. Therefore, established horsepower ratings refer to the power that the engine will produce at its rated rpm under a specific combination of weather conditions.

**THIS PAGE IS INTENTIONALLY BLANK**

# IMPORTANT INFORMATION

## Section 1B - Maintenance

**1  
B**

### Table of Contents

Maintenance Schedule .....	1B-2	Changing Oil and Filter .....	1B-11
Maintenance Intervals .....	1B-2	Priming Engines With Oil .....	1B-11
Scheduled Maintenance That Can		Tools Required .....	1B-11
Be Performed By Owner/Operator ...	1B-2	Procedure .....	1B-11
Scheduled Maintenance That Should		Power Steering System .....	1B-12
Be Performed By A Dealer .....	1B-3	Checking Fluid Level .....	1B-12
Engine and Tune-Up Specifications .....	1B-4	Filling and Bleeding .....	1B-13
Fluid Capacities .....	1B-5	Closed Cooling System .....	1B-14
Engine Rotation and Firing Order .....	1B-5	Checking Coolant Level .....	1B-14
L.H. Rotation Front .....	1B-5	Coolant for Closed Cooling System ..	1B-14
20-Hour Break-In Period .....	1B-5	Flushing System .....	1B-15
After Break-in Period .....	1B-6	Lubrication .....	1B-17
End of First Season Checkup .....	1B-6	Throttle Cable .....	1B-17
Fuel .....	1B-6	Shift Cable .....	1B-18
Fuel Ratings .....	1B-6	Engine Coupler / U-Joint Shaft	
General Information .....	1B-6	Splines .....	1B-18
Gasoline / Alcohol Blends .....	1B-7	Cold Weather or Extended Storage .....	1B-19
Effects of Gasoline / Alcohol Blends		Precautions .....	1B-19
on Marine Engines .....	1B-7	Power Package Layup .....	1B-20
Boat / Motor Storage .....	1B-8	Draining Instructions .....	1B-21
Winter Storage .....	1B-8	Single Point Drain System .....	1B-21
Warranty .....	1B-8	Draining Seawater (Raw-Water)	
Continuing Evaluations .....	1B-8	Cooled Models .....	1B-23
Test For Alcohol Content In Gasoline ..	1B-8	Draining Seawater Section of Closed	
Crankcase Oil .....	1B-9	Cooled (Coolant) Models .....	1B-26
Overfilled Crankcase Oil .....	1B-9	Recommissioning .....	1B-28
Adding Crankcase Oil .....	1B-10		
Checking Engine Oil Level/Filling ....	1B-10		

# Maintenance Schedule

## Maintenance Intervals

Maintenance intervals and the tasks to be performed, as shown in this current schedule, or as found in previously printed schedules, are generally based on an average boating application and environment. However, individual operating habits and personal maintenance preferences can have an impact on the suggested intervals. In consideration of these factors, MerCruiser has adjusted some maintenance intervals and corresponding tasks to be performed. In some cases, this may allow for more individual tasks to be performed in a single visit to the servicing dealer, rather than multiple visits. Therefore, it is very important that the boat owner and servicing dealer discuss the current Maintenance Schedule and develop appropriate maintenance intervals to coincide with the individual operating habits, environment and maintenance requirements.

## Scheduled Maintenance That Can Be Performed By Owner/Operator

**NOTE:** Only perform maintenance which applies to your particular power package.

Task	Interval
Engine Crankcase Oil - Check level.	Weekly
Closed Cooling Coolant - Check level.	
Power Steering Fluid - Check level.	
Sterndrive Unit Oil - Check level.	
Battery - Check level and inspect for damage.	
Fuel Pump Sight Tube (If Equipped) - Check that no fuel is present.	
Power Trim Pump Oil - Check level.	
Anodes - Inspect for erosion.	
Gear Housing Water Pickups - Check for marine growth or debris.	
Drive Belts (All) - Inspect condition and check tension.	Every 100 hours of operation or 120 days, whichever occurs first.
Propeller Shaft - Lubricate.	<b>Saltwater Use:</b> Every 50 hours of operation or 60 days, whichever occurs first.
Power Package Exterior Surfaces - Spray with rust preventative.	<b>Freshwater Use:</b> Every 100 hours of operation or 120 days, whichever occurs first.
Power Package Exterior Surfaces - Clean and paint.	Once a year
Cooling System - Flush seawater section.	<b>Saltwater Use:</b> After every use.



## Scheduled Maintenance That Should Be Performed By A Dealer

**NOTE:** Only perform maintenance which applies to your particular power package.

Task	Interval
Seawater Pickup Pump - Disassemble and inspect.	Whenever insufficient seawater flow is suspected (if operating temperature exceeds normal range.)
Crankcase Oil and Filter - Change.	End of first boating season and thereafter, every 100 hours of operation or once yearly, whichever occurs first.
Ignition System - Clean and inspect condition.	
Flame Arrestor and Crankcase Ventilation Hose - Clean and inspect.	
Positive Crankcase Ventilation (PCV) Valve (If Equipped) - Change.	
Sterndrive Unit Oil - Change.	
<b>Gimbal Ring Clamping Screws</b> - Retorque to 50-55 lb-ft (67-74 Nm).	
<b>Rear Engine Mounts</b> - Check, torque to 38 lb-ft (52 Nm).	
Gimbal Bearing - Lubricate.	
Cooling System - Clean and inspect.	
Steering System - Lubricate and inspect for loose, damaged or missing parts.	
Electrical System - Check for loose or damaged wiring.	
Closed Cooling System Pressure Cap - Clean, inspect and test.	
Cooling System Hoses and Clamps - Inspect for damage and deterioration. Check clamps for tightness.	
Continuity Circuit - Check components for loose connections, broken or frayed wires.	
Shift and Throttle Cable and Linkage - Lubricate and inspect for loose, damaged or missing parts.	
Engine Exhaust System - Inspect externally for damage, deterioration and restrictions. Check for tightness.	
Ignition System - Check timing and adjust as needed.	
Closed Cooling Coolant - Replace.	Every 5 years or 1000 hours, whichever occurs first <sup>1</sup>

<sup>1</sup>Only if Extended Life 5/100 Ethylene Glycol Antifreeze/Coolant is used. If any non-compatible coolant is added to this coolant, coolant must be changed every 2 years or 400 hours, whichever occurs first. All coolants other than Extended Life 5/100 Ethylene Glycol Antifreeze/Coolant must be changed every 2 years or 400 hours, whichever occurs first.

# Engine and Tune-Up Specifications

MODEL	MCM 3.0L
Propshaft Horsepower (SAV1 Rating)	135 <sup>1</sup> (114 <sup>2</sup> )
Propshaft Kilowatts (SAV1 Rating)	101 <sup>1</sup> (85 <sup>2</sup> )
Number of Cylinders	4
Displacement	181 cid (3.0L)
Bore/Stroke In. (mm)	4.00 X 3.60 (101.6 X 91.4)
Compression Ratio	9.25:1
Compression Pressure	Minimum 100 psi (690 kPa) <sup>7</sup>
Idle rpm (In Neutral) <sup>3</sup>	700 rpm <sup>5</sup>
Max rpm (At W.O.T.) <sup>3</sup>	4400-4800 rpm
Oil Pressure (at 2000 rpm)	Minimum 30 psi (207 kPa)
Fuel Pump psi (At 1000 rpm)	6-8 psi (41-55 kPa)
Minimum Oil Pressure At Idle	4 psi (28 kPa)
Electrical System	12 Volt Negative (-) Ground
Minimum Battery Requirements	375 cca / 475 mca / 90 Ah
Firing Order	1-3-4-2
Spark Plug Type	AC - MR43LTS Champion - RS12YC NGK - BPR6EFS
Spark Plug Gap	.035 in. (0.9 mm)
Timing (At Idle) <sup>4</sup>	1° BTDC <sup>8</sup> / 1° ATDC <sup>9</sup> / 2° ATDC <sup>10</sup>
Preliminary Idle Mixture	1 1/4 Turns
Thermostat	143° F (62° C) <sup>8</sup> / 160° F(71° C) <sup>10</sup>

<sup>1</sup> Power Rated in Accordance with NMMA (National Marine Manufacturers' Association) rating procedures.

<sup>2</sup> Power Rated in Accordance with SAV1 rating procedures. This rating procedure is used to certify that the engine complies with "Stage 1" Bodensee and Swiss Regulations. Horsepower differences shown result from differences in test rpm, allowable test tolerances, and/or installation of special kit components.

<sup>3</sup> Measured using an accurate service tachometer with engine at normal operating temperature.

<sup>4</sup> Timing must be set using a special procedure as outlined in the appropriate section of this manual. Timing cannot be properly set using the conventional method.

<sup>5</sup> A special procedure must be followed to adjust idle rpm. Consult your Authorized MerCruiser Dealer before attempting this procedure.

<sup>7</sup> Minimum recorded compression in any one cylinder should not be less than 70 percent of the highest recorded cylinder.

<sup>8</sup>Serial number break: 0L096999 and below

<sup>9</sup>Serial number break: 0L097000 - 0L0340999

<sup>10</sup>Serial number break: 0L341000 and above.

## Fluid Capacities

NOTICE	
Unit Of Measurement: U.S. Quarts (Liters)	
All capacities are approximate fluid measures.	

MODEL	MCM 181 cid / 3.0L
Crankcase (With Filter) <sup>1</sup>	4 (3.8)
Seawater Cooling System <sup>2</sup>	9 (8.5)
Closed Cooling System	9 (8.5)

<sup>1</sup> Always use dipstick to determine exact quantity of oil or fluid required.

<sup>2</sup> Seawater Cooling System capacity information is for winterization use only.

## Engine Rotation and Firing Order

### L.H. Rotation Front

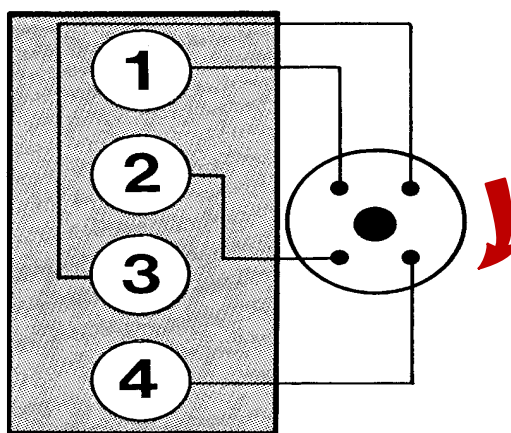

4 Cylinder - 181 cid / 3.0L

Firing Order 1-3-4-2

50683

## 20-Hour Break-In Period

**IMPORTANT:** The first 20 hours of operation is the engine break-in period. Correct break-in is essential to obtain minimum oil consumption and maximum engine performance. During this break-in period, the following rules must be observed:

- Do not operate below 1500 rpm for extended periods of time for first 10 hours. Shift into gear as soon as possible after starting and advance throttle above 1500 rpm **if conditions permit safe operation.**
- Do not operate at one speed consistently for extended periods.
- Do not exceed 3/4 throttle during first 10 hours. During next 10 hours, occasional operation at full throttle is permissible (5 minutes at a time maximum).
- Avoid full throttle acceleration from IDLE speed.
- Do not operate at full throttle until engine reaches normal operating temperature.

## After Break-in Period

To help extend the life of your MerCruiser power package, the following recommendations should be considered;

- Use a propeller that allows the engine to operate at or near the top of the maximum rpm range (See “Specifications” section) when at full throttle with a normal boat load.
- Operation at 3/4 throttle setting or lower is recommended. Refrain from prolonged operation at maximum (full throttle) rpm.

## End of First Season Checkup

At the end of the first season of operation, an Authorized MerCruiser Dealer should be contacted to discuss and/or perform various scheduled maintenance items. If you are in an area where the product is operated continuously (year-round operation), you should contact your dealer at the end of the first 100 hours of operation, or once yearly, whichever occurs first.

## Fuel

### Fuel Ratings

#### CAUTION

Use of improper gasoline can damage the engine seriously. Engine damage that results from use of improper gasoline is considered misuse of the engine and is not covered under MerCruiser Warranty.

### USA AND CANADA

Fuel having a posted pump Octane Rating of 87 (R + M) / 2 minimum. Premium gasoline [90 (R + M) / 2] is also acceptable. DO NOT use leaded gasolines.

### OUTSIDE USA AND CANADA

Fuel having a posted pump Octane Rating of 90 RON minimum. Premium gasoline (98 RON) is also acceptable. If unleaded is not available, use a major brand of leaded gasoline.

### General Information

Gasolines containing alcohol, either methyl alcohol (methanol) or ethyl alcohol (ethanol) may cause increased:

- Corrosion of metal parts.
- Deterioration of elastomer and plastic parts.
- Fuel permeation through flexible fuel lines.
- Wear and damage of internal engine parts.
- Starting and operating difficulties.