Service Manual Outline

Section 1 - Important Information

- A - General Information
- B - Maintenance
- C - Troubleshooting

Section 2 - Removal and Installation

- A - MCM Models
- B - MIE Models

Section 3 - Engine

- A - Engine Mechanical

Section 4 - Electrical System

- A - Starting System
- B - Ignition System
- C - Charging System
- D - Wiring Diagrams

Section 5 - Fuel System

- A - Fuel Delivery System

Section 6 - Cooling System

- A - All Models
- B - Seawater Cooled Models
- C - Closed Cooled Models

Section 7 - Exhaust System

- A - Manifolds and Elbows
- B - Collectors

Section 8 - Drives

- A - Velvet Drive In-Line And V-Drive Transmission
- B - Velvet Drive 5000 Series Transmission
- C - ZF/Hurth 630 And 800 Series Transmission

Section 9 - Power Steering

- A - Power Steering Pump

Important Information	1
Removal And Installation	2
Engine	3
Electrical System	4
Fuel System	5
Cooling System	6
Exhaust System	7
Drives	8
Power Steering	9

Notice

Throughout this publication, Dangers, Warnings and Cautions (accompanied by the International HAZARD Symbol ) are used to alert the mechanic to special instructions concerning a particular service or operation that may be hazardous if performed incorrectly or carelessly. **OBSERVE THEM CAREFULLY!**

These Safety Alerts alone cannot eliminate the hazards that they signal. Strict compliance to these special instructions when performing the service, plus Common Sense operation, are major accident prevention measures.

DANGER

Immediate hazards which will result in severe personal injury or death.

WARNING

Hazards or unsafe practices which could result in severe personal injury or death.

CAUTION

Hazards or unsafe practices which could result in minor personal injury or product or property damage.

Notice to Users of This Manual

This service manual has been written and published by the Service Department of Mercury Marine to aid our dealers' mechanics and company service personnel when servicing the products described herein.

It is assumed that these personnel are familiar with marine product servicing procedures. Furthermore, it is assumed that they have been trained in the recommended service procedures of Mercury MerCruiser product, including the use of mechanics' common hand tools and the special Mercury Marine or recommended tools from other suppliers.

We could not possibly know of and advise the marine trade of all conceivable procedures and of the possible hazards and/or results of each method. Therefore, anyone who uses a service procedure and/or tool, which is not recommended by the manufacturer, first must completely satisfy himself that neither his nor the products safety will be endangered.

All information, illustrations and specifications contained in this manual are based on the latest product information available at the time of publication. As required, revisions to this manual will be sent to all dealers contracted by us to sell and/or service these products.

We reserve the right to make changes to this manual without prior notification.

Refer to dealer service bulletins, operation maintenance and warranty manuals and installation manuals for other pertinent information concerning the products described in this manual.

Precautions

It should be kept in mind, while working on the product, that the electrical system and ignition system are capable of violent and damaging short circuits or severe electrical shocks. When performing any work where electrical terminals could possibly be grounded or touched by the mechanic, the battery cables should be disconnected at the battery.

Any time the intake or exhaust openings are exposed during service they should be covered to protect against accidental entrance of foreign material which could enter the cylinders and cause extensive internal damage when the engine is started.

It is important to note, during any maintenance procedure replacement fasteners must have the same measurements and strength as those removed. Numbers on the heads of the metric bolts and on the surfaces of metric nuts indicate their strength. American bolts use radial lines for this purpose, while most American nuts do not have strength markings. Mismatched or incorrect fasteners can result in damage or malfunction, or possibly personal injury. Therefore, fasteners removed should be saved for reuse in the same locations whenever possible. Where the fasteners are not satisfactory for re-use, care should be taken to select a replacement that matches the original.

Engine Mechanical Components

Many of the engine mechanical components are designed for marine applications. Unlike automotive engines, marine engines are subjected to extended periods of heavy load and wide open throttle operation and, therefore, require heavy-duty components. Special marine engine parts have design and manufacturing specifications that are required to provide long life and dependable performance. Marine engine parts also must be able to resist the corrosive action of salt or brackish water that will rust or corrode standard automotive parts within a short period of time.

Failure to use recommended Quicksilver service replacement parts can result in poor engine performance and/or durability, rapid corrosion of parts subjected to salt water and possibly complete failure of the engine.

Replacement Parts

Use of parts other than the recommended service replacement parts, will void the warranty on those parts that are damaged as a result.

WARNING

Electrical, ignition and fuel system components on Mercury MerCruiser Engines and Stern Drives are designed and manufactured to comply with U.S. Coast Guard Rules and Regulations to minimize risks of fire or explosion.

Use of replacement electrical, ignition or fuel system components, which do not comply to these rules and regulations, could result in a fire or explosion hazard and should be avoided.

When servicing the electrical, ignition and fuel systems, it is extremely important that all components are properly installed and tightened. If not, any electrical or ignition component opening would permit sparks to ignite fuel vapors from fuel system leaks, if they existed.

Models Covered in This Manual

Sterndrive (MCM)	Serial Number
5.0L MPI Alpha and Bravo	0M300000
350 MAG MPI Alpha and Bravo	
350 MAG MPI Alpha and Bravo Horizon	
MX 6.2 MPI	
MX 6.2 MPI Horizon	

Inboard and Tow Sports (MIE)	Serial Number
350 MAG MPI Inboard	0M310000
350 MAG MPI Horizon Inboard	
MX 6.2 MPI Inboard	
MX 6.2 MPI Horizon Inboard	
350 MAG MPI Tow Sports	

THIS PAGE IS INTENTIONALLY BLANK

IMPORTANT INFORMATION

Section 1A - General Information

Introduction	1A-2
How to Use This Manual	1A-2
Page Numbering	1A-2
Engine Serial Number Locations	1A-3
Mercury/Quicksilver Lubricants, Sealants And Adhesives	1A-4

IMPORTANT INFORMATION

Section 1B - Maintenance

Torque Specifications	1B-2	Closed Cooling System	1B-36
Special Tools	1B-2	Checking Coolant Level	1B-36
Lubricants / Sealants / Adhesives	1B-3	Cleaning and Inspection	1B-36
Engine And Tune-Up Specifications	1B-4	Changing Coolant	1B-36
MCM (Sterndrive) Models	1B-4	Anodes	1B-37
MIE (Tow Sports and Inboard) Models	1B-5	Propeller Shaft	1B-40
Fluid Specifications	1B-6	Power Package Surfaces	1B-41
Engines	1B-6	Painting Your Power Package	1B-41
Sterndrives	1B-6	Battery	1B-42
Transmissions	1B-7	Instruments	1B-42
Maintenance Schedules	1B-7	Gimbal Ring / Steering Connection	1B-42
Maintenance Intervals	1B-7	Changing Water Separating Fuel Filter	1B-43
Gas Sterndrive	1B-8	Steering System	1B-44
Routine Maintenance	1B-8	Remote Control	1B-44
Scheduled Maintenance	1B-9	Sterndrive Components	1B-44
Gas Inboard And Tow Sports	1B-11	Lubrication	1B-44
Routine Maintenance	1B-11	Throttle Cable	1B-44
Scheduled Maintenance	1B-12	Shift Cable and Transmission Linkage	1B-45
Crankcase Oil	1B-14	Sterndrive Components	1B-46
Overfilled Crankcase Oil	1B-15	Continuity Circuit	1B-50
Checking	1B-15	MerCathode	1B-52
Filling	1B-16	Engine Mounts	1B-52
Changing Oil and Filter	1B-17	Electrical System	1B-52
Flushing The Power Package - MCM	1B-19	Cleaning Flame Arrestor	1B-53
Sterndrive Water Pickups	1B-19	Serpentine Drive Belt	1B-54
Alternative Water Pickups	1B-21	Inboard and Tow Sports Models	1B-54
Flushing The Power Package - MIE	1B-23	Sterndrive Models	1B-55
Precautions	1B-23	Inspection	1B-55
Inboard Models	1B-23	Replacing Belt and/or Adjusting Tension	1B-56
Tow Sports Models	1B-25	Exhaust System	1B-57
Transmission Fluid	1B-27	Seawater Pump	1B-57
Checking	1B-27	Starter Motor	1B-58
Changing and Filling	1B-28	14MT	1B-58
Sterndrive Unit Oil	1B-28	Cold Weather And Extended Storage	1B-59
Checking	1B-28	Preparing Your Power Package For Storage	1B-59
Filling	1B-28	Draining Instructions	1B-61
Changing	1B-29	Identification	1B-62
Power Trim Pump Fluid	1B-31	Boat In The Water	1B-63
Checking	1B-31	Boat Out Of The Water	1B-67
Filling	1B-31	All Models	1B-70
Changing	1B-31		
Power Steering Pump Fluid	1B-32		
Checking	1B-32		
Filling and Bleeding	1B-33		
Water Inlets	1B-35		
Seawater Strainer	1B-35		

IMPORTANT INFORMATION

Section 1C - Troubleshooting

Used Spark Plug Analysis	1C-2	Engine Will Not Crank Over	1C-12
Normal Condition	1C-2	Charging System Inoperative	1C-12
Chipped Insulator	1C-3	Noisy Alternator	1C-13
Wet Fouling (Oil Deposits)	1C-3	Instrumentation Malfunction	1C-13
Cold Fouling	1C-4	Radio Noise	1C-13
Overheating	1C-4	Poor Fuel Economy	1C-14
High Speed Glazing	1C-5	Engine Runs Poorly at Idle	1C-15
Scavenger Deposits	1C-5	Engine Runs Poorly At High RPM	1C-16
Pre-Ignition Damage	1C-6	Engine Acceleration Is Poor	1C-17
Reversed Coil Polarity	1C-6	Troubleshooting with Vacuum Gauge	1C-17
Splashed Deposits	1C-7	Engine Noise	1C-18
Mechanical Damage	1C-7	Important Information	1C-18
Poor Boat Performance And/Or		Oil Pressure	1C-24
Poor Maneuverability	1C-8	Excessive Oil Consumption	1C-27
Improper Full Throttle Engine RPM	1C-10	Water In The Engine	1C-28
Engine Cranks Over But Will Not Start		Important Information	1C-28
Or Starts Hard	1C-11	Engine Overheats (Mechanical)	1C-30
Important Information	1C-11	Power Steering	1C-33
		Drain System Will Not Drain Or Drains Slowly	1C-35

REMOVAL AND INSTALLATION

Section 2A - MCM Models

Torque Specifications	2A-2	Fluid Connections	2A-18
Lubricants / Sealants / Adhesives	2A-3	Fuel	2A-18
Special Tools	2A-4	Gear Lube Monitor Hose	2A-19
Removal	2A-5	Power Steering Hoses	2A-20
Engine Installation	2A-8	Bravo Models and	
Electrical Connections	2A-13	Alpha Seawater Cooled Models	
EFI Electrical System Precautions ..	2A-13	Using Sterndrive Water Pickups	2A-21
Installing Continuity Wire	2A-14	Alpha or Bravo Models	
Instrumentation Connections	2A-14	Using Alternative Water Pickups ...	2A-21
Trim Position Sender Connections ..	2A-15	Coolant Recovery Bottle	2A-24
MerCathode Connections	2A-16	Shift Cable Installation	2A-25
Audio Warning Alarm Connections ..	2A-17	Alpha Models -	
Power Trim Pump Connections	2A-17	Drive Unit Not Installed	2A-25
		Bravo Models	2A-30
		Throttle Cable Installation	
		and Adjustment	2A-35
		Battery Connection	2A-37
		Engine Cover Installation	2A-37

REMOVAL AND INSTALLATION

Section 2B - MIE Models

Torque Specifications	2B-2	Exhaust System Hose / Tube	
Lubricants / Sealants / Adhesives	2B-2	Connections	2B-12
Removal	2B-3	Electrical Connections	2B-13
Engine Mount Pre-Adjustment	2B-6	EFI Electrical System Precautions ...	2B-13
Engine Preparation	2B-7	Instrumentation Connections	2B-13
Engine Oil Dipstick Relocation	2B-7	Fluid Connections	2B-14
Engine Installation and Initial Engine		Final Engine Alignment	2B-15
Alignment	2B-8	Engine Cover Installation	2B-19
Models With 8 Degree Down Angle		Fuel Supply Connections	2B-20
Transmissions	2B-8	Throttle Cable Installation and	
Models with V-Drive Transmissions ..	2B-10	Adjustment	2B-20
All Models	2B-11	Shift Cable Installation And Adjustment	2B-20

ENGINE

Section 3A - Engine Mechanical

Identification	3A-3	Rocker Arm / Valve Pushrod	3A-31
General Specifications	3A-4	Removal	3A-31
5.0 l (305 cid)	3A-4	Cleaning	3A-31
5.7 l (350 cid)	3A-4	Inspection	3A-31
6.2 l (377 cid)	3A-5	Installation	3A-32
Engine Specifications -		Valve Stem Oil Seal / Valve Spring -	
5.0 l (305 cid) and 5.7 l (350 cid)	3A-6	Cylinder Head Installed	3A-33
Cylinder Head	3A-6	Exploded View	3A-33
Cylinder Bore	3A-6	Removal	3A-34
Oil Pump	3A-6	Installation	3A-35
Piston Bore Clearance	3A-6	Valve Adjustment	3A-38
Piston Rings	3A-7	Engine Stopped	3A-38
Piston Pin	3A-7	Intake Manifold Assembly	3A-40
Crankshaft	3A-8	Exploded View	3A-40
Connecting Rod	3A-9	Removal	3A-41
Valve	3A-9	Cleaning	3A-43
Camshaft	3A-11	Inspection	3A-43
Timing Chain	3A-11	Upper And Lower Intake Manifolds ..	3A-43
Flywheel	3A-11	Installation	3A-43
Engine Specifications - 6.2 l (377 cid) ..	3A-12	Hydraulic Valve Lifters	3A-46
Cylinder Head	3A-12	Exploded View	3A-46
Cylinder Bore	3A-12	Special Information	3A-46
Oil Pump	3A-12	Removal	3A-47
Piston Clearance	3A-12	Cleaning	3A-48
Piston Rings	3A-13	Inspection	3A-48
Piston Pin	3A-13	Installation	3A-49
Crankshaft	3A-14	Camshaft and Camshaft Bearings	3A-50
Connecting Rod	3A-15	Measuring Camshaft Lobe Lift	3A-50
Valve	3A-15	Removal	3A-52
Camshaft	3A-17	Cleaning	3A-54
Timing Chain	3A-17	Inspection	3A-54
Flywheel	3A-17	Installation	3A-55
Torque Specifications	3A-18	Cylinder Head	3A-59
Special Tools	3A-22	Removal	3A-59
Lubricants / Sealants / Adhesives	3A-23	Disassembly	3A-60
Precautions	3A-25	Cleaning	3A-61
General Information	3A-26	Inspection	3A-62
Repair Procedures	3A-26	Repair	3A-67
Special Notice	3A-26	Reassembly	3A-72
Engine Rotation	3A-26	Installation	3A-75
Crankcase Oil Dipstick Measurements	3A-27	Oil Pan	3A-77
Engine Mounts	3A-28	Removal	3A-77
Exploded Views	3A-28	Cleaning	3A-77
Valve Cover	3A-30	Inspection	3A-78
Removal	3A-30	Installation	3A-78
Cleaning and Inspection	3A-30		
Installation	3A-30		

Section 3A - Engine Mechanical (continued)

Oil Pump	3A-81	Timing Chain And Sprockets	3A-150
Exploded View	3A-81	Removal	3A-150
Removal	3A-82	Cleaning	3A-151
Disassembly	3A-82	Inspection	3A-151
Cleaning	3A-83	Reassembly	3A-151
Inspection	3A-83	Installation	3A-152
Reassembly	3A-84	Flywheel Housing	3A-153
Installation	3A-86	Removal	3A-153
Crankshaft Balancer	3A-87	Cleaning	3A-154
Removal	3A-87	Inspection	3A-154
Cleaning	3A-87	Installation	3A-154
Inspection	3A-87	Flywheel	3A-155
Installation	3A-88	Removal	3A-155
Front Cover Oil Seal	3A-90	Cleaning and Inspection	3A-156
Oil Seal Replacement Without Removing		Installation	3A-156
Front Cover	3A-90	Rear Oil Seal	3A-158
Front Cover	3A-91	Removal	3A-158
Removal	3A-91	Cleaning	3A-159
Cleaning and Inspection	3A-92	Inspection	3A-159
Installation	3A-92	Installation	3A-159
Connecting Rod, Bearings and		Rear Oil Seal Retainer	3A-161
Piston Assembly	3A-94	Removal	3A-161
Exploded View	3A-94	Cleaning	3A-161
Removal	3A-95	Inspection	3A-161
Disassembly	3A-96	Installation	3A-162
Cleaning	3A-97	Oil Filter By-Pass Valve and	
Inspection	3A-97	Block Adapter	3A-163
Reassembly	3A-112	Exploded View	3A-163
Installation	3A-115	Removal	3A-164
Crankshaft, Main Bearings		Cleaning	3A-165
And Engine Block	3A-119	Inspection	3A-165
Exploded View	3A-119	Installation	3A-166
Removal	3A-120		
Cleaning	3A-123		
Inspection	3A-126		
Installation	3A-138		

ELECTRICAL SYSTEM

Section 4A - Starting System

Identification	4A-2	Delco 14MT Starter	4A-8
Replacement Parts Warning	4A-3	Specifications	4A-8
General Precautions	4A-3	Starter Specifications	4A-8
Typical Starting System Components	4A-4	Torque Specifications	4A-8
Positive Current Flow	4A-5	Lubricants / Sealants / Adhesives	4A-8
Battery	4A-5	Description	4A-8
Battery Cable Recommendations	4A-5	Testing	4A-9
Delco PG260F1 Starter	4A-6	Removal	4A-11
Specifications	4A-6	Solenoid Switch	4A-12
Starter Specifications	4A-6	Inspection	4A-12
Torque Specifications	4A-6	Installation	4A-13
Delco PG260L Starter	4A-7		
Specifications	4A-7		
Starter Specifications	4A-7		
Torque Specifications	4A-7		

ELECTRICAL SYSTEM

Section 4B - Ignition System

Specifications	4B-2	Ignition Coil	4B-7
Spark Plugs	4B-2	Removal	4B-7
Distributor	4B-2	Installation	4B-8
Coil	4B-2	Distributor	4B-9
Firing Order	4B-2	Removal	4B-9
Torque Specifications	4B-2	Disassembly	4B-10
Lubricants / Sealants / Adhesives	4B-3	Cleaning and Inspection	4B-12
Spark Plugs	4B-3	Reassembly	4B-12
Removal	4B-3	Installation	4B-13
Inspection	4B-3		
Replacing	4B-4		
Spark Plug Wires	4B-5		
Inspection	4B-5		
Replacing	4B-5		

ELECTRICAL SYSTEM

Section 4C - Charging System

Delco Alternator	4C-2	Troubleshooting Tests	
Identification	4C-2	(Alternator on Engine)	4C-5
Replacement Parts Warning	4C-2	Charging System	4C-6
Specifications	4C-3	Resistance	4C-7
Torque Specifications	4C-3	Circuitry	4C-9
Special Tools	4C-3	Removal	4C-11
Precautions	4C-4	Alternator	4C-11
EFI Electrical System Precautions ..	4C-4	Alternator Bracket	4C-11
Charging System Components	4C-5	Installation	4C-12
Periodic Maintenance	4C-5	Alternator Bracket	4C-12
		Alternator	4C-12
		Battery Isolator Diagram	4C-14

ELECTRICAL SYSTEM

Section 4D - Wiring Diagrams

Instrumentation	4D-2	MerCathode System Wiring Diagram ..	4D-5
Single Station Installations - Typical .	4D-2	Wiring Diagrams	4D-6
Power Trim System	4D-4		

FUEL SYSTEM

Section 5A - Fuel Delivery System

Specifications	5A-2	Electronic Control Module (ECM)	5A-18
Torque Specifications	5A-2	Removal	5A-18
Special Tools	5A-3	Cleaning and Inspection	5A-18
Lubricants / Sealants / Adhesives	5A-3	Installation	5A-18
Replacement Parts Warning	5A-3	Water Separating Fuel Filter	5A-19
Abbreviations	5A-4	Removal	5A-20
Precautions	5A-5	Installation	5A-20
Fuel Supply Connections	5A-5	Cool Fuel System	5A-20
Fuel Delivery System	5A-6	Removal	5A-20
Recommendations	5A-6	Disassembly	5A-22
Exploded Views	5A-7	Reassembly	5A-24
Fuel Rail and Injectors	5A-7	Installation	5A-28
Throttle Body	5A-8	Intake Manifold	5A-29
Cool Fuel System	5A-9	Removal	5A-29
Fuel System Flow Diagrams	5A-10	Disassembly	5A-31
Sensor Locations	5A-11	Cleaning and Inspection	5A-35
Fuel Pressure Relief Procedure	5A-13	Assembly	5A-35
Flame Arrestor	5A-13	Installation	5A-37
Removal	5A-13	Sensors	5A-41
Cleaning and Inspection	5A-13	Manifold Air Pressure / Temperature	
Installation	5A-13	(MAPT) Sensor	5A-41
Throttle Body	5A-14	Throttle Position Sensor (TPS)	5A-42
Removal	5A-14	Idle Air Control (IAC) Valve	5A-44
Cleaning and Inspection	5A-16	Knock Sensor	5A-45
Installation	5A-17	Fuel Pump Relay	5A-46
		Main Power Relay	5A-47

COOLING SYSTEM

Section 6A - All Models

Torque Specifications	6A-2	Seawater Pump	6A-12
Lubricants / Sealants / Adhesives	6A-2	Output Test	6A-12
Seawater Inlet Recommendations	6A-3	Removal	6A-14
Seacock (Seawater Inlet Valve)	6A-3	Disassembly	6A-15
Seawater Strainer	6A-3	Cleaning and Inspection	6A-16
Seawater Pickups	6A-4	Reassembly	6A-16
Through the Hull Mounted	6A-4	Installation	6A-19
Transom Mounted	6A-6	Water Circulating Pump	6A-20
Quicksilver Sea Strainer	6A-8	Removal	6A-20
Removal	6A-8	Cleaning and Inspection	6A-21
Cleaning and Inspection	6A-9	Installation	6A-22
Installation	6A-10	Water Distribution Housing	6A-23
Auxiliary Hot Water Heater Installation ..	6A-11	Removal	6A-23
Supply Hose Connection	6A-11	Cleaning And Inspection	6A-23
Return Hose Connection	6A-12	Installation	6A-23

COOLING SYSTEM

Section 6B - Seawater Cooled Models

Torque Specifications	6B-2	Water Tap Location For Shaft Log Seal .	6B-6
Lubricants / Sealants / Adhesives	6B-2	Water Flow Diagrams	6B-7
Specifications	6B-2	Seawater Cooled Models With	
Seawater Cooling System Capacity .	6B-2	An Engine Mounted Seawater Pump	6B-7
Thermostat	6B-2	Seawater Cooled Models Without	
Flushing Seawater Cooling System	6B-3	An Engine Mounted Seawater Pump	6B-8
Thermostat	6B-3		
Removal	6B-3		
Testing	6B-4		
Installation	6B-5		

COOLING SYSTEM

Section 6C - Closed Cooled Models

Torque Specifications	6C-2	Thermostat	6C-12
Lubricants / Sealants / Adhesives	6C-2	Removal	6C-12
Specifications	6C-2	Testing	6C-12
Closed Cooling System Capacity	6C-2	Installation	6C-14
Coolant Specification	6C-2	Heat Exchanger	6C-15
Thermostat	6C-2	Testing	6C-15
Pressure Cap Rating	6C-2	Removal	6C-15
Description	6C-3	Disassembly	6C-16
Coolant Recommendations	6C-3	Cleaning And Inspection	6C-16
Maintaining Coolant Level	6C-4	Repair	6C-16
Pressure Cap Maintenance	6C-5	Assembly	6C-17
Testing Closed Cooling System	6C-6	Installation	6C-18
Testing Coolant for Alkalinity	6C-6	Heat Exchanger Bracket Hardware	6C-19
Pressure Testing System	6C-7	Heat Exchanger Hose Connections	6C-20
Testing for Cylinder Head Gasket		Water Tap Location For Shaft Log Seal .	6C-21
Leak	6C-9	Closed Cooling System Water Flow	
Testing Pressure Cap	6C-10	Diagram	6C-22

EXHAUST SYSTEM

Section 7A - Manifolds, Elbows And Risers

Torque Specifications	7A-2	Cleaning and Inspection	7A-5
Lubricants / Sealants / Adhesives	7A-2	Manifold Leak Test	7A-6
Exploded View	7A-3	Installation	7A-6
Removal	7A-4		

EXHAUST SYSTEM

Section 7B - Collectors

Torque Specifications	7B-2	Cleaning and Inspection	7B-10
Lubricants / Sealants / Adhesives	7B-2	Installation	7B-11
Important Information	7B-3	Air Tube Routing	7B-12
Exhaust Y -Pipe	7B-4	Air Pump Maintenance	7B-13
Water Shutter	7B-4	Troubleshooting Silent Choice	
Through Transom Exhaust	7B-6	Exhaust Silencer System	7B-14
Water Shutter	7B-6	Exhaust Muffler Kit	7B-15
Below Swim Platform Exhaust Pipe	7B-8	Removal	7B-15
Removal	7B-8	Maintenance	7B-15
Cleaning And Inspection	7B-8	Cleaning and Inspection	7B-16
Installation	7B-8	Installation	7B-17
Silent Choice Exhaust System	7B-9		
Removal	7B-9		

DRIVES

Section 8A - Velvet Drive In-Line And V-Drive Transmission

Identification	8A-2	Removal	8A-10
Specifications	8A-3	Installation	8A-11
Operating Specifications	8A-3	Shift Lever Installation	8A-13
Ratios And Part Numbers	8A-3	Shift Control And Cables	8A-14
Fluid Specifications	8A-4	Transmission Shift Lever and Shift	
Pressure Specifications	8A-4	Cable Bracket	8A-15
Torque Specifications	8A-4	Installation and Adjustment	8A-16
Lubricants / Sealants / Adhesives	8A-5	Pressure Test	8A-20
Precautions	8A-5	Transmission Repair	8A-20
Transmission / Propeller Rotation	8A-6		
Fluid Level	8A-7		
Checking	8A-7		
Changing	8A-7		
Filling	8A-9		

DRIVES

Section 8B - Velvet Drive 5000 Series Transmission

Identification	8B-2	Removal	8B-9
Specifications	8B-3	Installation	8B-10
Ratios and Part Numbers	8B-3	Shift Lever Installation	8B-12
Fluid Specifications	8B-3	Shift Control And Cables	8B-13
Pressure Specifications	8B-4	Transmission Shift Lever and Shift	
Torque Specifications	8B-4	Cable Bracket	8B-14
Lubricants / Sealants / Adhesives	8B-4	Installation and Adjustment	8B-16
Precautions	8B-5	Pressure Test	8B-20
Transmission / Propeller Rotation	8B-6	Transmission Repair	8B-20
Fluid Level	8B-7		
Checking	8B-7		
Changing	8B-7		
Filling	8B-8		

DRIVES

Section 8C - ZF/Hurth 630 And 800 Series Transmission

Identification	8C-2	Removal	8C-9
Specifications	8C-3	Installation	8C-10
Operating Specifications	8C-3	Shift Control And Cables	8C-13
Ratios and Part Numbers	8C-3	Transmission Shift Lever and Shift	
Fluid Specifications	8C-4	Cable Bracket	8C-13
Pressure Specifications	8C-4	Installation and Adjustment	8C-15
Torque Specifications	8C-4	Pressure Test	8C-19
Special Tools	8C-4	Transmission Repair	8C-19
Lubricants / Sealants / Adhesives	8C-5		
Precautions	8C-5		
Transmission / Propeller Rotation	8C-6		
Fluid Level	8C-7		
Checking	8C-7		
Changing	8C-7		
Filling	8C-8		

POWER STEERING

Section 9A - Power Steering Pump

Torque Specifications	9A-2	Replacing Belt And/Or Adjusting Tension	9A-10
Lubricants / Sealants / Adhesives	9A-2	Filling And Bleeding	9A-10
Special Tools	9A-2	Checking Fluid Level	9A-10
Precautions	9A-3	Hydraulic Hoses And Fluid Cooler	9A-11
Power Steering Pump And		High Pressure Hose	
Components Exploded View	9A-3	(Pump-To-Control Valve)	9A-11
Power Steering Pump Pulley		Low Pressure Hose	
Replacement	9A-4	(Pump-To-Fluid Cooler)	9A-13
Removal	9A-4	Low Pressure Hose	
Installation	9A-4	(Control Valve-To-Fluid Cooler)	9A-15
Power Steering Pump	9A-5		
Removal	9A-5		
Flow Control Valve Servicing	9A-6		
Pump Shaft Oil Seal Replacement	9A-7		
Installation	9A-9		

THIS PAGE IS INTENTIONALLY BLANK

IMPORTANT INFORMATION

Section 1A - General Information



Table of Contents

Introduction	1A-2
How to Use This Manual	1A-2
Page Numbering	1A-2
Engine Serial Number Locations	1A-3
Mercury/Quicksilver Lubricants, Sealants And Adhesives	1A-4

Introduction

This comprehensive overhaul and repair manual is designed as a service guide for the models previously listed. It provides specific information, including procedures for disassembly, inspection, assembly and adjustment to enable dealers and service mechanics to repair and tune these engines.

Before attempting repairs or tune-up, it is suggested that the procedure first be read through to gain knowledge of the methods and tools used and the cautions and warnings required for safety.

How To Use This Manual

This manual is divided into sections which represent major components and systems.

Some sections are further divided into parts that more fully describe the component.

Refer to the Service Manual Outline following Models Covered In This Manual for section titles.

Page Identification

The service manual number and section title appear at the top of the page. Two number groups appear at the bottom of each page. Following is an example and a description.

Page 1A-2

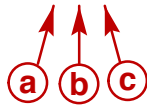

90-17431--4 FEBRUARY 1998

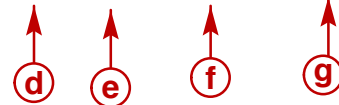

- a** - Section Number
- b** - Section Part
- c** - Page Number
- d** - Manual Number
- e** - Revision Number
- f** - Month Printed
- g** - Year Printed



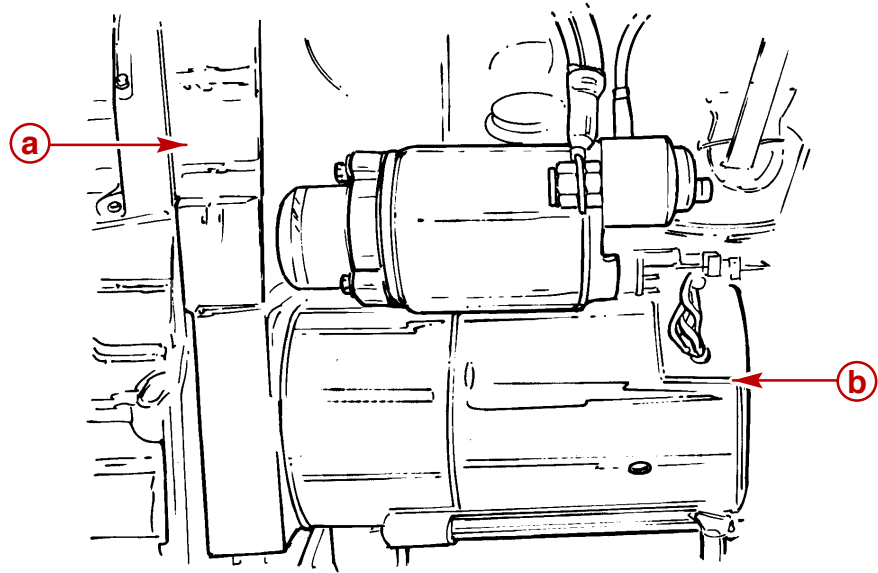







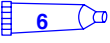

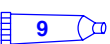
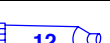

Engine Serial Number Locations

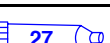

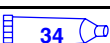
78018

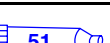
- a** - Serial Number Plate
- b** - Starter Motor

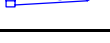
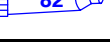
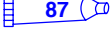
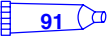
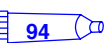
Mercury/Quicksilver Lubricants, Sealants And Adhesives

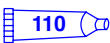
Tube Ref. #	Description	Container Size	Mercury Part Number	Quicksilver Part Number
 4	Needle Bearing Assy. Lubricant	8 oz (226.8 g) tube	N/A	92-802868A1
 6	Dielectric Grease	8 oz (226.8 g) can	N/A	92-823506-1
 7	Loctite 271 - Thread Locker	10 ml tube	N/A	92-809819
 9	Loctite 567 PST Pipe Sealant	50 ml tube	N/A	92-809822
 12	Loctite Master Gasket Kit		N/A	92-12564-2
 14	2 Cycle Premium Outboard Oil	1 US qt (0.94 L)	92-802813A1	92-802813Q1
 19	Perfect Seal	16 oz (0.45 kg) can	N/A	92-34227-1
 25	Liquid Neoprene	8 oz (226.8 g) can	N/A	92-25711-3
 27	Bellows Adhesive	1.5 oz (42.5 g) tube	N/A	92-86166Q1
 33	Loctite 680 Retaining Compound	10 ml tube	N/A	92-809833
 34	Special Lubricant 101	8 oz (226.8 g) tube	92-802865A1	92-802865Q1
 42	U-Joint and Gimbal Bearing Grease		92-802870A1	92-802870Q1
 51	Loctite 222 Thread Locker	10 ml tube	N/A	92-809818
 66	Loctite 242 Thread Locker	10 ml tube	N/A	92-809821
 79	4 Cycle 25W40 Engine Oil		92-802837A1	92-802837Q1
 82	Premium Gear Lubricant	1 US qt (0.94 L)	92-802846A1	92-802846Q1
 87	High Performance Gear Lube	1 US qt (0.94 L)	92-802854A1	92-802854Q1
 91	Engine Coupler Spline Grease	14 oz (0.39 kg) cartridge	92-802869A1	92-802869Q1
 94	Anti-Corrosion Grease	8 oz (226.8 g) tube	92-802867A1	92-802867Q1
 95	2-4-C with Teflon	8 oz (226.8 g) tube	92-802859A1	92-802859Q1
 110	4 Stroke 10W30 Outboard Oil	1 US qt (0.94 L)	92-802833A1	92-802833Q1
 114	Power Trim & Steering Fluid	8 oz (226.8 g)	92-802880A1	92-802880Q1