

Workshop Manual

"LK" Models

Electrical & Ignition

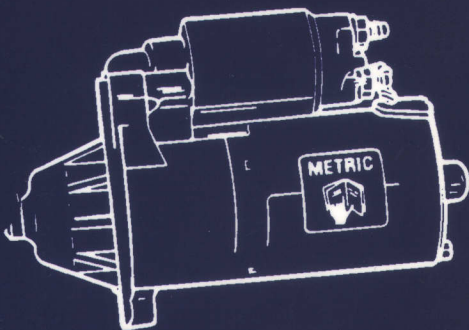
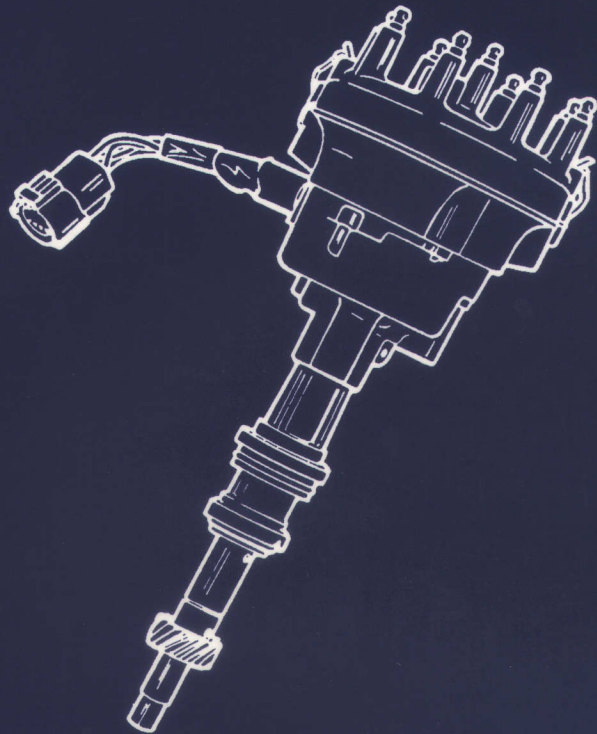
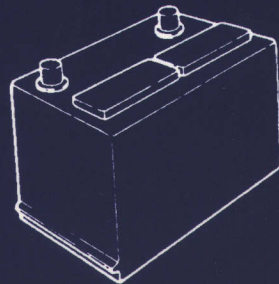
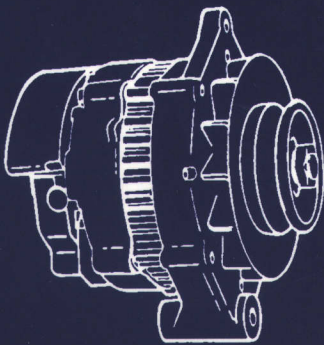

Safety Warning

This Workshop Manual will alert you to certain procedures that must be done very carefully. If you ignore this information, you could...

- Injure yourself or people around you
- Injure the boat operator, boat passengers, or people around the boat
- Damage the Volvo Penta product or its systems

Understand the following symbols before proceeding:

 Safety Warning	Alerts you to the possibility of danger and identifies information that will help prevent injuries.
Note	Identifies information that will help prevent damage to machinery.
Important	Appears next to information that controls correct assembly and operation of the product.

This Workshop Manual is written for qualified, factory trained service technicians familiar with the use of Volvo Penta special tools.

This Workshop Manual tells you how to correctly maintain and service Volvo Penta products and systems. When correctly serviced, the Volvo Penta product will be reliable and safe to operate.

When Volvo Penta special tools are called for, use them. Where mentioned, the tools are required to perform the service procedure.

If you use service procedures or service tools that are not recommended in this manual, **YOU ALONE** must decide if your actions might injure people or damage the Volvo Penta product.

General Information	1
Cranking System	2
Charging System	3
Trim/Tilt system - Electrical	4
<i>Delco EST</i> Ignition system	5
<i>Prestolite BID</i> Ignition System	6
7.4GL Ignition system	7
GM EFI Electrical System	8
Electrical Wiring Diagrams	9
Safety	S

This workshop manual is one of a set of eight that covers Volvo Penta sterndrive models. All eight books can be ordered as a set from Volvo Penta Parts. Order P/N 7797360-0.

Individual workshop manuals covering these models are also available. Order the following part numbers from *Volvo Penta Parts*.

- ***P/N 7797361-8 Engine Components***

Includes information on Engine service and troubleshooting; Engine removal and installation; Steering systems; Throttle and Shift Control systems; and Cooling systems.

- ***P/N 7797362-6 Electrical & Ignition System***

Includes service and troubleshooting information on Cranking systems; Charging systems; Trim/Tilt electrical systems; Ignition systems; and Engine and Instrument wiring diagrams.

- ***P/N 7797363-4 Fuel System***

Includes service and troubleshooting information on all carburetor, MFI and TBI fuel systems and related components.

- ***P/N 7797364-2 EFI Diagnostic Manual GM***

Contains troubleshooting procedures for all Electronic Fuel Injected GM models and related components.

- ***P/N 7797365-9 PJX WaterJet***

Contains service information for repair and overhaul of the waterjet system.

- ***P/N 7797366-7 DPX - Workshop Manual***

Includes specific information for repair and overhaul of the DPX Sterndrive and Xact™ steering systems.

- ***P/N 7797367-5 SX and DP-S Sterndrives and Transom Shield***

Includes information on Transom Shield, Upper Gear Unit and Lower Gear Unit service; Drive Unit removal and installation; Propellers; and Trim/Tilt hydraulic operation.

- ***P/N 7797368-3 SP and DP Workshop Manual***

Includes Upper Gear Unit and Lower Gear Unit overhaul procedures, installation and removal.

This Volvo Penta Workshop Manual Covers The Following Volvo Penta "LK" Models

Engine

3.0 LITER		4.3 LITER		7.4 LITER	
30GSMLKD	3868646	43GLPLKD	3868618	74GLPLKD	3868626
30GSPLKD	3868647	43GSPLKD	3868619	74GiPLKDCE	3868627
		43GiPLKDCE	3868620	74GSiPLKD	3868742
		5.7 LITER		8.2 LITER	
		57GLPLKD	3868621	82GSiPLKD	3868743
		57GLPLKR	3868699		
		57GSPLKD	3868598		
		57GLiPLKDCE	3868732		
		57GiPLKDCE	3868623		
		57GSiPLKD	3868624		
		57GSiCPLKD	3868686		

Transom Shield

SX-C1	3868404
SX-CLT1	3868432
SX-C1AC	3868515
SX-C2AC	3868820

Stern Drive

SX-C1	1.43:1	3868392	DP-S	2.30:1	3868163	DPX-S1	1.59:1	3868637
SX-C1	1.51:1	3868393	DP-S	1.95:1	3868164	DPX-S1	1.68:1	3868638
SX-C1	1.60:1	3868394	DP-S	1.78:1	3868165	DPX-S1	1.78:1	3868639
SX-C1	1.66:1	3868395	DP-S	1.68:1	3868166			
SX-CT1	1.97:1	3868397	DP-S1	2:30:1	3868601			
SX-RT1	1.66:1	3868398	DP-S1	1.95:1	3868602			
SX-RT2	1.66:1	3868587	DP-S1	1.78:1	3868603			
SX-C2	1.41:1	3868581	DP-S1	1.68:1	3868604			
SX-C2	1.51:1	3868582						
SX-C2	1.60:1	3868583						
SX-C2	1.66:1	3868584						
SX-C1	1.85:1	3868465						
SX-RT1	2.18:1	3868333						
SX-RT2	2.18:1	3868588						

Jet Drive

PJX-C	3868694
PJX-C1	3868694

Volvo Penta Model Identification

Note All sterndrive systems must be matched for either single or dual engine installations. Failure to properly match engine, transom bracket and sterndrive will result in poor boat performance, and risk or damage to the engine and or drive because of incorrect drive gear ratio.

The model identification is located on the engine valve cover, and **MUST** correspond with the transom bracket and sterndrive numbers as listed in this document.

- Engine Model Number **1** **2** **3**
- Transom Bracket Model Number **4**
- Sterndrive Model Number **5**

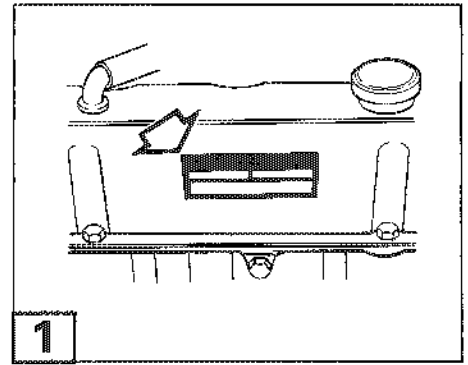

DR1145

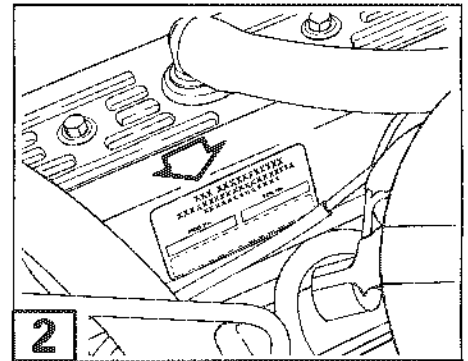

DR4282

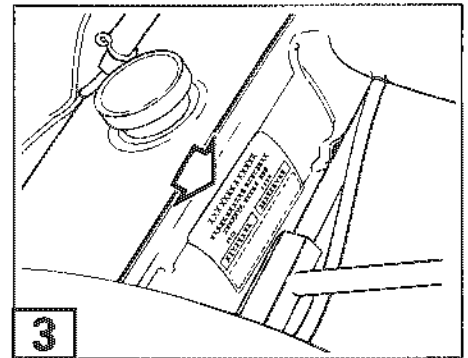

DR4944

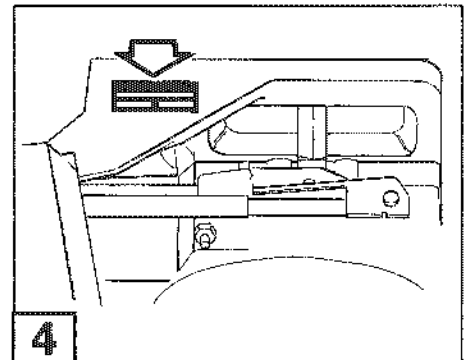

DR2058

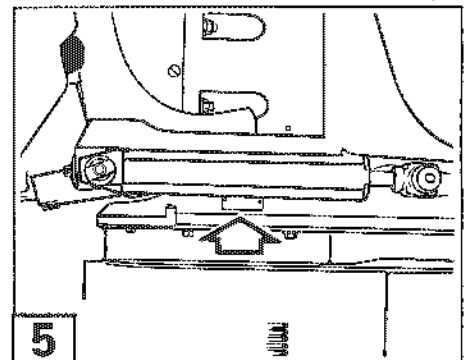

DR4967

Elect/eng

Section 1

General Information

Table of Contents

Battery and Cables	1-5
Circuit Protection	1-9
Circuit Protectors and Locations.	1-10
Connector Service	
Amphenol	1-16
Packard	1-18
Conversion Charts	
Drill	1-28
Metric	1-27
Ignition Switch	1-15
Introduction	1-2
Oil and Water Sending Units	1-11
Periodic Maintenance Chart	1-30
Relays	1-8
Solenoids	1-7
Spark Plugs and Leads	1-13
Symbols	1-29
Torque Specifications, General.....	1-30
Troubleshooting	
System Isolation	1-19
Engine Troubleshooting Guides.....	1-20
Tachometer	1-15
Tuning the Engine.....	1-4

Safety Warning

Before working on any part of the electrical system, read the section called Safety at the end of this manual.

The original mounting, support and routing of electrical system parts conform with U.S. Coast Guard requirements. It is important to maintain the original mounting, support and routing after servicing the electrical system to prevent possible fire and explosion in boat's engine compartment.

Do not substitute automotive parts. *Volvo Penta* marine components meet U.S. Coast Guard regulations for external ignition proof operation and marine use. *Volvo Penta* marine components are specially designed not to cause ignition of fuel vapors in the bilge or engine compartment. The use of automotive parts can result in fire and explosion.

Introduction

This service manual covers Volvo Penta Sterndrive models. It is divided into sections concerning various systems and assemblies. Refer to the Contents to locate the section covering the system or assembly requiring service. Each section title page has an additional listing that will describe the section's contents in more detail. Be sure to read the Safety Section at the end of this manual, and pay special attention to all safety warnings as they appear throughout the text. Since models are subject to change at any time, some photos may not depict actual product.

Good Service Practice

Service required for Volvo Penta Sterndrives is generally one of three kinds:

- **Normal care and maintenance** - which includes putting a new stern drive into operation, storing engines, lubrication, and care under special operating conditions such as salt water and cold weather.
- **Operating malfunctions** - due to improper engine or drive mounting, propeller condition or size, boat condition, or the malfunction of some part of the engine. This includes engine servicing procedures to keep the engine in prime operating condition.
- **Complete disassembly and overhaul** - such as major service or rebuilding a unit.

It is important to determine before disassembly just what the trouble is and how to correct it quickly, with minimum expense to the owner.

When repairing an assembly, the most reliable way to ensure a good job is to do a complete overhaul on that assembly, rather than just to replace the bad part. Wear not readily apparent on other parts could cause malfunction soon after the repair job. Repair kits and seal kits contain all the parts needed to ensure a complete repair, to eliminate guesswork, and to save time.

Repair time can also be minimized by the use of special tools. Volvo Penta special tools are designed to perform service procedures unique to the product that cannot be completed using tools from other sources. They also speed repair work to help achieve service flat rate times. In some cases, the use of substitute tools can damage the part.

Note Do not operate engine out of water even momentarily. If operated in test tank, use proper test wheel. Failure to do so can damage water pump, overheat engine, or allow excessive engine RPM.

Preparation for Service

Proper preparation is extremely helpful for efficient service work. A clean work area at the start of each job will minimize tools and parts becoming misplaced. Clean an engine that is excessively dirty before work starts. Cleaning will occasionally uncover trouble sources. Obtain tools, instruments and parts needed for the job before work is started. Interrupting a job to locate special tools or repair kits is a needless delay.

 Use proper lifting and handling equipment. **Working on stern drives without proper equipment can cause damage and personal injury.**

Always use clean fresh fuel when testing engines. Troubles can often be traced to the use of old or dirty fuel.

Service Policy

Whether within or following the warranty period, Volvo Penta has a constant interest in their products.

It is a Volvo Penta policy to provide dealers with service knowledge so they can give professional service demanded by today's consumer. The Volvo Penta Training Centers, frequent mailing of Service Bulletins, Letters and Promotions, Special Tools and this Service Manual represent our continuing efforts to assist dealers in giving consumers the best and most prompt service possible. This Service Manual covers all phases of servicing Volvo Penta Sterndrives. If a service question does not appear to be answered in this manual, you are invited to write to the Volvo Penta Service Department for additional help. Always be sure to give complete information, including engine model number and serial number.

Be sure that you are familiar with the Volvo Penta Warranty. If you have any questions, write the Volvo Penta Service Department. If other than genuine Volvo Penta replacement components or parts are used, Volvo Penta may refuse subsequent warranty claims involving that engine.

When a brand-name product or specific tool is called for, another item may be used. However, the substitute must have equivalent characteristics, including type, strength, and material. You must determine if incorrect substitution could result in product malfunction and personal injury to anyone. To avoid hazards, equivalent products which are used must meet all current U.S. Coast Guard Safety Regulations and ABYC standards.



Replacement Parts

 When replacement parts are required, always use genuine Volvo Penta parts, or parts with equivalent characteristics, including type, strength, and material. Failure to do so may result in product malfunction and possible injury to the operator and/or passengers.

Parts Catalogs

Parts Catalogs contain exploded views showing the correct assembly of all parts, as well as a complete listing of the parts for replacement. These catalogs are available from Volvo Penta Parts. Individual purchasers of Parts Catalogs must order Parts Catalogs through an authorized dealer.

Special Service Tools

Volvo Penta has specially designed tools to simplify some of the disassembly and assembly operations. These tools are illustrated in this Service Manual, in many cases in actual use. All Volvo Penta special tools can be ordered from Volvo Penta Parts. Individual purchasers of Service Manuals must order Special Tools through an authorized dealer.

Product References, Illustrations & Specifications

Volvo Penta of the Americas reserves the right to make changes at anytime, without notice, in specifications and models and also to discontinue models. The right is also reserved to change any specifications or parts at any time without incurring any obligation to equip same on models manufactured prior to date of such change. All information, illustrations and specifications contained in this manual are based on the latest product information available at the time of printing. The right is reserved to make changes at anytime without notice.

All photographs and illustrations used in this manual may not depict actual models or equipment, but are intended as representative views for reference only. The continuing accuracy of this manual cannot be guaranteed.

Tuning The Engine

The purpose of an engine tune-up is to restore power and performance that has been lost through wear, corrosion or deterioration of one or more parts or components. In the normal operation of an engine, these changes can take place gradually at a number of points, so that it is seldom advisable to attempt an improvement in performance by correction of one or two items only. Time will be saved and more lasting results will be obtained by following a definite and thorough procedure of analysis and correction of all items affecting power and performance. Refer to the **Engine Service Manual** for all tune-up specifications.



Battery and Cables

Special Tools Required: Battery Hydrometer

The primary function of the battery is to provide power to operate the starter motor. The battery also supplies power to operate the lights and other electrical equipment which may be used when the engine is not running. On battery ignition systems, the battery must supply the ignition current during the starting period and during the time that the alternator is not producing a sufficient charge to meet operating requirements.

Battery Requirements

The boat should be equipped with a 12 volt battery capable of handling all normal electrical needs. **All GL and GS Models (except 7.4 GL):** We recommend a 360 amp cold cranking rating at 0° F (-18° C), 115 minutes reserve capacity rating at 80° F (27° C) as a minimum. **All Gi, GSi and 7.4 GL Models:** We recommend a 650 amp cold cranking rating of 0° F (-18° C), 165 minutes reserve capacity rating at 80° F (27° C) as a minimum. A maintenance free battery is acceptable as long as it meets the minimum battery requirements.

Battery Maintenance

There are two things which must be done periodically in order to obtain long life from a battery.

1. The electrolyte must be kept above the plates and separators at all times. The liquid level should be brought up to the level specified by the battery manufacturer. Acid should never be added except when it is definitely known that some has been lost by spilling, and then only by an experienced battery man.

⚠ Battery electrolyte is a corrosive acid and should be handled with care. If electrolyte is spilled or splashed on any part of the body, immediately flush the exposed area with liberal amounts of water and obtain medical aid as soon as possible.

- 1** 2. Be sure that the battery is kept nearly at full charge at all times. The state of charge should be checked at frequent intervals by making specific gravity readings with a battery hydrometer. It is suggested that gravity readings and replacement of evaporated water be made every two weeks. Should the gravity fall more than 0.040 specific gravity below a fully charged gravity reading, remove the battery and have it charged.

Note Full charge specific gravity is 1.260 at 80° F (27° C).

⚠ Do not use a jumper cable and a booster battery to start engine. Remove battery from boat and recharge. Fumes vented during charging battery can lead to an explosion.

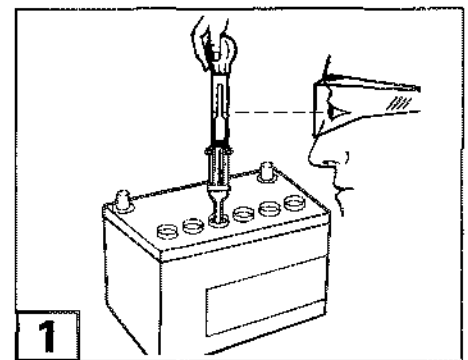

Good Battery Servicing Includes the Following Nine Points:

1. Protect boat against acid damage.
2. Clean battery.
3. Inspect cables.
4. Clean terminals.
5. Inspect hold-downs.
6. Inspect casing for leaks.
7. Make hydrometer test.
8. Remove battery from boat for tests. Recharge battery if less than 3/4 charged. Make load test.
9. Add water.

If battery is not in a good state of charge or if it uses an excessive amount of water, check the charging system.

Clean the battery and terminals with a solution of baking soda and water. This will neutralize the acid on the battery. After washing with this solution, flush top of battery with clear water. Care must be taken when washing the battery so that the baking soda and water solution does not enter the battery cells.

Cable Requirements

The battery should be mounted as close to the engine as practical to cut down on battery cable lengths. Follow the recommendations below.

All Carbureted Models

- 0-10 Feet 1 Gauge
- 10-15 Feet 2/0 Gauge
- 15-20 Feet 3/0 Gauge

All EFI Models

- 0-10 Feet 0 Gauge
- 10-15 Feet 2/0 Gauge
- 15-20 Feet 4/0 Gauge

Note These specifications do not apply to aluminum battery cables. Volvo Penta does not recommend the use of aluminum battery cables.

 **To prevent possible explosion or fire, do not substitute automotive parts for the following marine components: starter, alternator, distributor and related ignition parts, spark plug leads, solenoids, carburetor (and related parts), fuel pump or fuel filter canister. These components have been specifically designed not to emit fuel vapors or to cause ignition of fuel vapors in the bilge.**



Solenoids

Special Service Tools Required: Test Light or Continuity Meter and Carbon Pile

The purpose of the solenoid assembly is to perform mechanical jobs electromagnetically. In the case of the solenoid used with the starter, this job consists of completing the heavy electrical circuit between the battery and the motor.

1 The solenoid is a completely sealed unit which consists of a plunger (A) and contact disk assembly (B), a coil winding (C), a contact disk return spring (D), and four terminals which protrude from the solenoid body. The two larger terminals (E) are the battery and motor terminals, while the smaller ones (F) are the switch control terminal, and terminal for sending battery voltage to the ignition system during engine cranking. Grounding is by an external ground wire in the engine harness, and internally (through bracket).

Note Recoat all electrical connections after reassembly with Black Neoprene Dip.

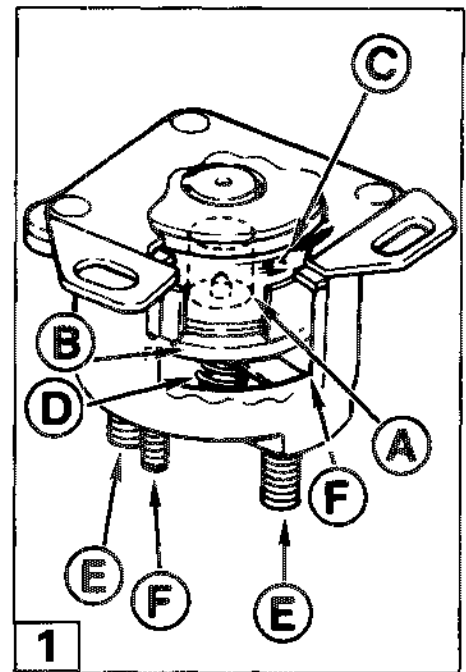

DR3196

In operation, when the ignition switch is closed, an electric current flows through the coil winding, causing the plunger and contact disk to be drawn inward. When drawn inward, the contact disk completes the circuit between the battery, motor and ignition terminals, allowing the battery current to flow.

A return spring is located just below the contact disk. When the electrical circuit as described above is completed, the spring is compressed by the magnetic pull on the plunger and contact disk. When the electrical circuit is broken (ignition switch released), the magnetic pull on the plunger and contact disk drops to zero. At this time, the compressed return spring breaks the circuit by pushing the contact disk away from the motor and battery studs of the solenoid.

Inspection Procedure

The solenoid used with the starter motor has proven to be trouble free under normal operating conditions. No periodic service is required other than a check to ensure that all connections are clean and tight.

Test Procedure

Being a completely sealed unit, repair or troubleshooting of detail parts is impractical. If a solenoid is suspected of being inoperative, it should be tested as follows.

Note Ensure solenoid has a good ground. Grounding is done by a ground wire in the engine wiring harness and through the base.

1 1. Connect a continuity light or ohmmeter (A), set to high ohms, to the two large terminals (B) of the solenoid.

1 2. Connect a carbon pile (C) in series with a battery (D) and reduce the voltage to less than six volts. Connect battery leads to the one small terminal of the solenoid and the base.

3. Increase the voltage until the continuity meter or test light shows a completed circuit. Stop and note the voltage reading - it should be between six and eight volts. If the solenoid requires more than eight volts to complete the circuit it should be replaced since, in actual use, it may not perform satisfactorily.

Service and Repair Procedure

None - replace a malfunctioning unit.

Relays

Special Service Tools Required: Ohmmeter or Test Light

The purpose of the relay assembly is to use a low amperage electrical circuit to control a high amperage circuit. In the case of a relay used in a starting circuit, the low amperage circuit from the key switch will control the high amperage circuit from the battery to the starter motor.

Inspection Procedure

The relays used in stern drive electrical circuits have proven to be trouble free under normal operating conditions. No periodic service is required. To prevent corrosion, all terminals of the relay and socket should be covered with Terminal Grease.

Relay Ohmmeter Tests

Note Throughout this section two symbols are used to interpret electrical troubleshooting results.

2 This symbol indicates continuity or very low resistance.

3 This symbol indicates no continuity or very high resistance (∞).

Note To avoid damaging components or troubleshooting equipment, disconnect the battery cables from the battery and remove the relays before proceeding.

1. Use a continuity light or ohmmeter calibrated on appropriate scale to test continuity.

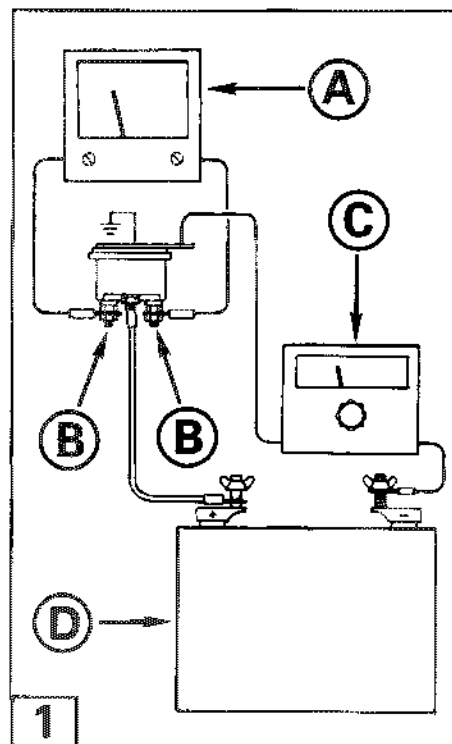

DR3202

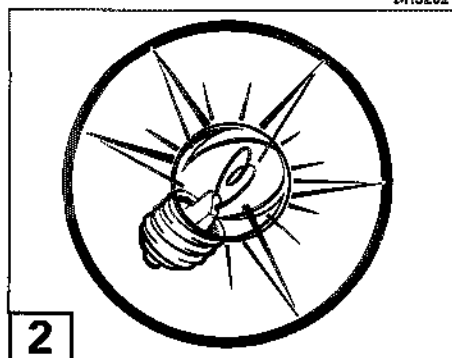

DR2065

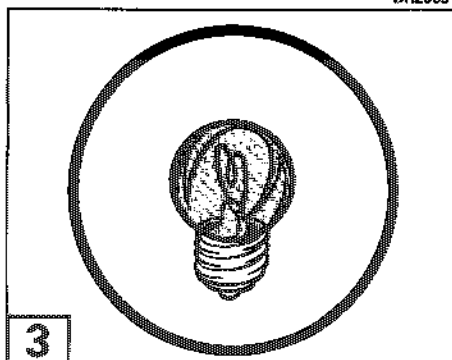

DR2065

4 2. Connect meter leads to relay terminals 87a and 30.

- The meter must show **continuity**.

5 3. Connect meter leads to relay terminals 87 and 30.

- The meter must show **no continuity**.

6 4. Calibrate an ohmmeter on appropriate scale and connect the leads to relay terminals 85 and 86.

- The meter must show 70 - 100 ohms.

7 5. Connect meter leads to relay terminals 87 and 30. Connect a 12 volt source to relay terminals 85 and 86.

- The meter must show **continuity**.

8 6. Connect meter leads to relay terminals 87a and 30. Connect a 12 volt source to relay terminals 85 and 86.

- The meter must show **no continuity**.

7. Replace relay if your test results vary.

Circuit Protection

⚠ Do not attempt to connect or disconnect any part of the electrical circuit while the engine is running.

When installing additional electrical accessories always use individual fused circuits. Power takeoff should be made at a terminal strip powered by auxiliary accessory wire and protected by a 30 amp (maximum) fuse.

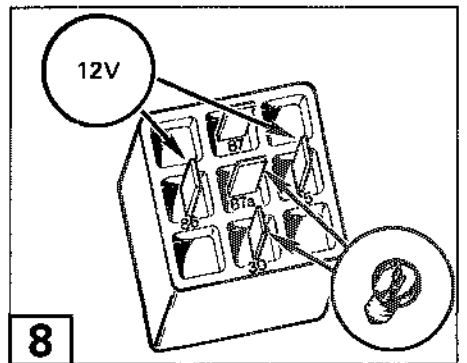
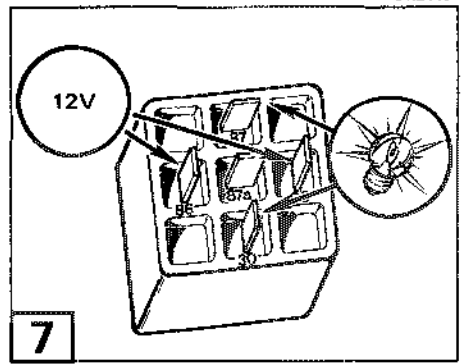
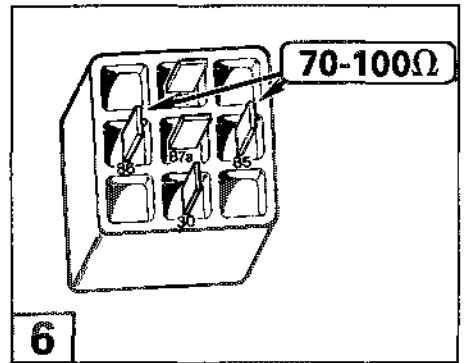
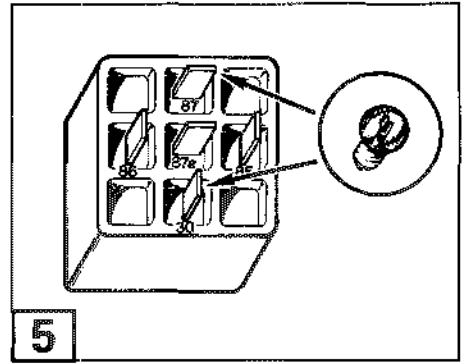
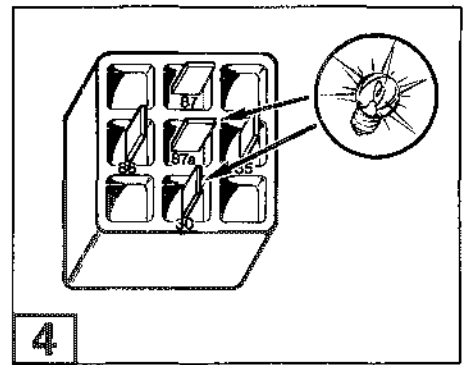

Circuit Protectors and Locations

10 Amp Circuit Breaker*

Protects trim switch. Located on trim/tilt pump.

SFE 20 Amp Fuse*

Protects ignition switch. Located under dash.

12.5 Amp Circuit Breaker¹

Protects ignition module. Located at front of starboard high-rise exhaust elbow.

12.5 Amp Circuit Breaker²

Protects fuel pump. Located at starboard front of engine.

12.5 Amp Circuit Breaker³

Protects ignition/injector relay and ECM. Located at front of starboard high-rise exhaust elbow.

20 Amp Circuit Breaker³

Protects fuel pumps. Located at port front of engine.

50 Amp Circuit Breaker *

Protects trim/tilt motor. Located at front of starboard high-rise exhaust elbow.

50 Amp Circuit Breaker !

Protects main harness. Located at front of starboard high-rise exhaust elbow.

60 Amp Circuit Breaker³

Protects main harness. Located at front of starboard high-rise exhaust elbow.

* All Models

¹ 7.4 GL Models Only

² 4.3 GL, GS Models Only

³ All Gi and GSi Models Only

! Carbureted Models Only

Oil and Water Sending Units

Special Tools Required: Ohmmeter

Inspection Procedure

Check wiring and connections between senders and gauges. Check to see that senders are operating properly. Inspect orifice in oil pressure sender for blockage.

Test Procedure - Gauge Sending Units

Oil Pressure Sender: To check oil gauge senders, start engine and run up from slow to fast. Observe gauge. If reading is unsatisfactory, check sender with an ohmmeter:

- 0 PSI . . . 227-257 ohms
- 40 PSI . . . 92-114 ohms
- 80 PSI . . . 21.5-49.5 ohms

Replace sender with a new one if it fails the ohmmeter checks. Retest; if reading is still unsatisfactory, problem may be in gauge, engine lubrication system or excessive bearing wear. Refer to appropriate **Engine Section**, paragraph **Oil Pump Service**.

To check gauge, disconnect wire at sender, turn ignition switch on, and momentarily ground sender wire. Gauge needle will peg at high side of scale if gauge is operating properly.

Water Temperature Sender: To check water temperature senders, remove sender from engine. Connect sender to a digital ohmmeter. Immerse sender in a container of oil with a cooking thermometer. Heat oil over a flameless source. Observe meter and thermometer. Meter should indicate:

- 448 ohms \pm 10% at 100° F (38° C)
- 128 ohms \pm 7.5% at 160° F (71° C)
- 46.6 ohms \pm 5% at 220° F (105° C)

Test Procedures - Audible Warning Switches (if equipped)

Oil Pressure Switch: The oil pressure audible warning switch is calibrated to make or break contact at 4 ± 2 PSI ($27,6 \pm 13,8$ kPa). Use an ohmmeter to make the following continuity checks. Replace the switch if it fails either of these tests.

1. With the engine off and the switch wire disconnected, there should be a full continuity (zero) reading between the switch terminal and engine block.
2. With the engine running and switch wire disconnected, there should be no continuity (infinity) reading between the switch terminal and engine block.

Water Temperature Switch: The water temperature audible warning switch is calibrated to make or break contact at $200^\circ \pm 5^\circ$ F ($93^\circ \pm 5^\circ$ C). Attach an ohmmeter to the switch and make the following check. Replace the switch if it fails this test.

1. Immerse switch in a container of oil. Heat oil over a flameless source and check temperature with a cooking thermometer.
2. Below the make/break temperature, the ohmmeter should show a no continuity (infinity) reading. Above the make/break temperature, the ohmmeter should show a full continuity (zero) reading.

Test Procedure - Audible Warning Horn (if equipped)

Note Under normal conditions, horn will sound when ignition is turned on. Horn will continue to sound until engine is started and oil pressure exceeds 4 ± 2 PSI ($27,6 \pm 13,8$ kPa).

The dash mounted audible warning horn can be tested as follows. Replace the horn if it fails this test.

1. Turn ignition switch to the ON position. Do not start engine.
2. If horn does not sound, disconnect the lead at the water temperature audible warning switch, and momentarily touch lead terminal to engine block. If audible warning horn does not sound, horn is defective, or wiring of switch-horn-ignition switch circuit has lost continuity.
3. Disconnect the lead at the oil pressure audible warning switch, and momentarily touch lead terminal to engine block. If audible warning horn does not sound, horn is defective, or wiring of switch-horn-ignition switch circuit has lost continuity.

Spark Plugs and Leads

Removal and Inspection

1. To disconnect wires, twist and pull only on boot because pulling on wire may cause separation of the core of the wire. Remove spark plugs using a $\frac{5}{8}$ in. spark plug socket or a $\frac{5}{8}$ in. box wrench. Use care to avoid cracking the spark plug insulators.

2. Carefully inspect the insulators and electrodes of all spark plugs. Replace any spark plug which has a cracked or broken insulator or which has loose electrodes. If the insulator is worn away around the center electrode, or the electrodes are burned or worn, the spark plug is worn out and should be discarded. Spark plugs which are in good condition, except for carbon or oxide deposits, should be thoroughly cleaned and gapped.

3. The spark plug wires are a special resistance type. The core is carbon impregnated linen. This type wire is superior to copper core wire in its resistance to cross-fire; however, it is more easily damaged than copper core. For this reason, care must be taken so that the spark plug wires are removed by pulling on the spark plug boots rather than on the wire insulation. If the wire is stretched, the core may be broken with no evidence of damage on the outer insulation. If the core is broken, it will cause misfiring. In the case of wire damage, it is necessary to replace the complete wire assembly since a satisfactory repair cannot be made.

4. Use an ohmmeter to test ignition leads for excessive high resistance or an open circuit. Proper resistance is 3,000-7,000 ohms per foot.

 5. Clean ignition wires with a cloth moistened in kerosene, and wipe dry. Bend wires to check for brittle, cracked or loose insulation. **Defective insulation will permit misfiring, cross-firing, or spark to ground, therefore defective wires must be replaced.**

6. If the wires are in good condition, clean any terminals that are corroded and replace any that are broken or distorted. Replace any wires with broken or deteriorated cable nipples or spark plug boots.

Spark Plug Cleaning

Spark plugs which have carbon or oxide deposits should be cleaned in a blast type spark plug cleaner. Scraping with a pointed tool will not properly remove the deposits and may damage the insulator. If spark plugs have a wet or oily deposit, dip them in a degreasing solvent and dry thoroughly with compressed air. Oily plugs will cause the cleaning compound to pack in the shell.



Carefully follow the instructions of the manufacturer of the cleaner being used. Clean each plug until the interior of shell and entire insulator is cleaned. Avoid excessive blasting.

1. Examine interior of plug in good light. Remove any cleaning compound with compressed air. If traces of carbon or oxide remain in plug, finish the cleaning with a light blasting operation. Clean firing surfaces of center and side electrodes with several strokes of a fine cut file.

2. When spark plugs have been thoroughly cleaned, carefully inspect them for cracks or other defects which may not have been visible before cleaning.

Adjust Spark Plug Gap

Use a round wire feeler gauge to check the gap between the spark plug electrodes. Flat feeler gauges will not give a correct measurement if the electrodes are worn. Adjust gap by bending the side electrode only. Bending the center electrode will crack the insulator. Setting the spark plug gap to any other specification in an attempt to improve idle or affect engine performance is not recommended.

Installation of Spark Plugs and Wires

- 3.0 GS Models **1**
- V-6 Models **2**
- V-8 Models **3**

For proper engine performance it is very important that the correct spark plugs be used. When installing spark plugs, make sure that the threads in the cylinder head and all surfaces on plugs and in cylinder heads are clean. Tighten spark plugs the specified amount. All engines use tapered seat plugs without gaskets.

⚠ Do not operate engine if spark plug boots or high tension leads are torn or cracked. This condition can allow external sparks which could ignite any fuel vapors in the engine compartment.

Spark plug wires must be arranged between the distributor cap and spark plugs in the order of firing sequence. If spark plug wires are not correctly installed, misfiring or cross-firing will result.

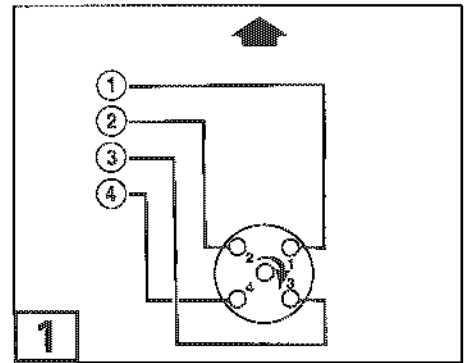

DR2451

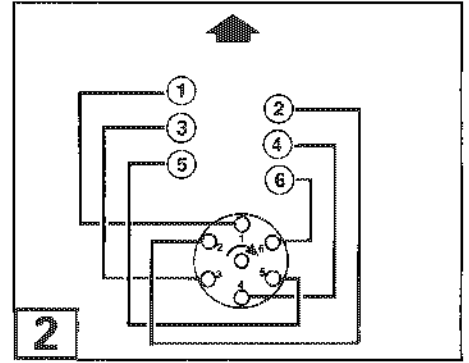

DR2448

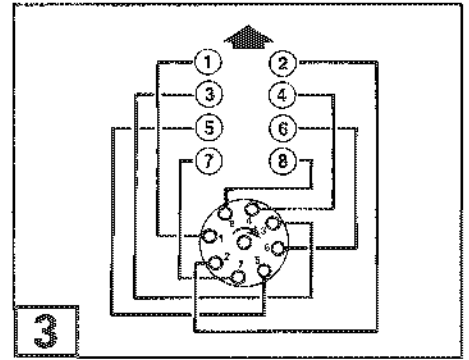

DR2453

