

HINSHI-H9019

SERVICE MANUAL

MARINE DIESEL ENGINE

4LHA-ST (Z) E

2000. 3. 10

FORWARD

This service manual has been compiled for engineers engaged in sales service, inspection and maintenance. Accordingly, descriptions of the construction and functions of the engine are emphasized in this manual while items which should already be common knowledge are omitted.

One characteristic of a marine diesel engine is that its performance in a vessel is governed by its applicability to the vessel's hull construction and its steering system.

Engine installation, fitting out and propeller selection have a substantial effect on the performance of the engine and the vessel. Moreover, when the engine runs unevenly or when trouble occurs, it is essential to check a wide range of operating conditions—such as installation on the hull and suitability of the ship's piping and propeller—and not just the engine itself. To get maximum performance from this engine, you should completely understand its functions, construction and capabilities, as well as proper use and servicing.

Use this manual as a handy reference in daily inspection and maintenance, and as a text for engineering guidance.

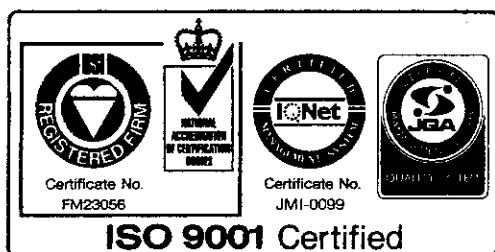

These products have been developed, designed and manufactured in the facilities certified by the Standards for Quality systems of ISO 9001.

Model 4LHA-STE

CHAPTER 0 FOR SAFETY

1. FOR SAFE SERVICING.....	0-1
2. PRECAUTION FOR SAFE SERVICING.....	0-2
(A) Service Shop (Place).....	0-2
(B) Working Wear.....	0-3
(C) Tools to Be Used.....	0-3
(D) Use of Genuine Parts, Oil and Grease.....	0-3
(E) Bolt and Nut Tightening Torques.....	0-3
(F) Electrical Parts.....	0-4
(G) Waste Treatment.....	0-4
(H) Handling the Product.....	0-5

CHAPTER 1 GENERAL

1. Exterior Views.....	1-1
2. Specifications.....	1-2
3. Service Standards.....	1-3
4. Performance Curves.....	1-5
5. Dimensions.....	1-6
6. Piping Diagrams.....	1-7
7. Electrical Diagrams.....	1-8

CHAPTER 2 BASIC ENGINE

1. Disassembly and Reassembly Tools.....	2-1
2. Cylinder Block.....	2-9
3. Cylinder Liners.....	2-12
4. Cylinder Head.....	2-14
5. Piston and Piston Pins.....	2-21
6. Connecting Rod.....	2-25
7. Crankshaft and Main Bearing.....	2-28
8. Camshaft and Tappets.....	2-32
9. Timing Gear.....	2-35
10. Flywheel.....	2-36

CHAPTER 3 FUEL INJECTION EQUIPMENT

3-1. DISTRIBUTOR TYPE

1. Fuel Supply System.....	3-1-1
2. Bleeding and Checking Injection Timing.....	3-1-2
3. Fuel Injection Pump Outline.....	3-1-4
4. Fuel System.....	3-1-5
5. Injection Pump Construction and Operation.....	3-1-6
6. Governing Mechanism.....	3-1-16
7. Timer Construction and Operation.....	3-1-38
8. Magnet Valve.....	3-1-43
9. Pump Reassembly, Adjustment and Inspection.....	3-1-44
10. Test Bench Adjustment of VE Pump.....	3-1-52
11. Troubleshooting.....	3-1-55
12. Fuel Injection Nozzle.....	3-1-59
13. Fuel Filter.....	3-1-63

3-2. YPES-AL TYPE

1. Fuel Supply System.....	3-2-1
2. Disassembly, Reassembly and Inspection of Governor.....	3-2-15
3. Disassembly, Reassembly and Inspection of Fuel Injection Pump.....	3-2-21
4. Adjustment of Fuel Injection and Governor.....	3-2-31
5. Automatic Advancing Timer.....	3-2-38
6. Fuel Feed Pump.....	3-2-40
7. Fuel Injection Nozzle.....	3-2-43
8. Troubleshooting.....	3-2-48
9. Tools.....	3-2-50
10. Fuel Injection Pump Specifications.....	3-2-53
11. Service Data.....	3-2-54

CHAPTER 4 INTAKE AND EXHAUST SYSTEM

1. Intake and Exhaust System.....	4-1
2. Intake Silencer.....	4-2
3. Intake Manifold.....	4-3
4. Turbocharger.....	4-4
5. Mixing Elbow.....	4-26
6. Breather.....	4-27

CHAPTER 5 LUBRICATION SYSTEM

1. Lubrication System.....	5-1
2. Lube Oil Pump.....	5-3
3. Lube Oil Filter.....	5-6
4. Oil Pressure Control Valve.....	5-8
5. Lube Oil Cooler.....	5-9
6. Piston Cooling Nozzle.....	5-10
7. Rotary Waste Oil Pump (Optional).....	5-11

CHAPTER 6 COOLING WATER SYSTEM

1. Cooling Water System.....	6-1
2. Sea Water Pump.....	6-4
3. Fresh Water Pump.....	6-7
4. Heat Exchanger.....	6-10
5. Pressure Cap and Sub Tank.....	6-12
6. Thermostat.....	6-14
7. Kingston Cock (Optional).....	6-16
8. Sea Water Filter (Optional).....	6-17
9. Bilge Pump and Bilge Strainer (Optional).....	6-18

CHAPTER 7 REDUCTION AND REVERSING GEAR

7-1. Marine gear model KM5A

1. Construction.....	7-1-1
2. Shifting Device.....	7-1-5
3. Inspection and Servicing.....	7-1-10
4. Special Tools.....	7-1-20
5. Disassembly.....	7-1-21
6. Reassembly.....	7-1-29

7-2. Marine gear model HSW630A1

1. Construction.....	7-2-1
2. Shifting Device.....	7-2-2
3. Inspection and Servicing.....	7-2-6
4. Disassembly.....	7-2-9
5. Reassembly.....	7-2-23

CHAPTER 8 REMOTE CONTROL (OPTIONAL)

1. Remote Control System.....	8-1
2. Remote Control Installation.....	8-2
3. Remote Control Inspection.....	8-5
4. Remote Control Adjustment.....	8-6

CHAPTER 9 ELECTRICAL SYSTEM

1. System Diagram.....	9-1
2. Battery.....	9-3
3. Starter Motor.....	9-7
4. Alternator.....	9-17
5. Instrument Panel.....	9-35
6. Warning Devices.....	9-37
7. Tachometer.....	9-40

CHAPTER 0
FOR SAFETY

1. FOR SAFE SERVICING.....	0-1
2. PRECAUTION FOR SAFE SERVICING.....	0-2
(A) Service Shop (Place).....	0-2
(B) Working Wear.....	0-3
(C) Tools to Be Used.....	0-3
(D) Use of Genuine Parts, Oil and Grease.....	0-3
(E) Bolt and Nut Tightening Torques.....	0-3
(F) Electrical Parts.....	0-4
(G) Waste Treatment.....	0-4
(H) Handling the Product.....	0-5

1. For Safe Servicing

- Most accidents are caused by failing to observe basic safety rules and precautions. To prevent accidents, it is important to recognize the signs of approaching problems, and eliminate the problems in the early stage before they can cause accidents.

Please read this manual carefully before starting repairs or maintenance to fully understand safety precautions and appropriate inspection and maintenance procedures. Attempting a repair or maintenance job without sufficient knowledge may cause an unexpected accident.

- It is impossible to cover every possible danger in repair or maintenance in the manual. Sufficient consideration for safety is required in addition to the matters marked  CAUTION. Especially for safety precautions in a repair or maintenance job not described in this manual, receive instructions from a knowledgeable leader.

- Safety marks used in this manual and their meanings are as follows:



DANGER indicates an imminently hazardous situation which, if not avoided, will result in death or serious injury.



WARNING indicates a potentially hazardous situation which, if not avoided, could result in death or serious injury.



CAUTION indicates a potentially hazardous situation which, if not avoided, may result in minor or moderate injury.

- Any matter marked [NOTICE] in this manual is especially important in servicing. If not observed, the product performance and quality may not be guaranteed.

2. Precaution For Safe Servicing

(A) Service Shop (place)

WARNING

● Place allowing sufficient ventilation

Jobs such as engine running, part welding and polishing the paint with sandpaper should be done in a well-ventilated place.

[Failure to Observe]

Very dangerous for human body due to the possibility of inhaling poisonous gas or dust.



CAUTION

● Sufficiently wide and flat place

The floor space of the service shop for inspection and maintenance should be sufficiently wide and flat without any holes.

[Failure to Observe]

An accident such as a violent fall may be caused.

CAUTION

● Clean, orderly arranged place

No dust, mud, oil or parts should be left on the floor surface.

[Failure to Observe]

An unexpected accident may be caused.

CAUTION

● Bright, safety illuminated place

The working place should be illuminated sufficiently and safely.

For a job in a dark place where it is difficult to see, use a portable safety lamp.

The bulb should be covered with a wire cage for protection.

[Failure to Observe]

The bulb may be broken accidentally causing ignition of leaking oil.



CAUTION

● Place equipped with a fire extinguisher

Keep a first aid kit and fire extinguisher close at hand in preparation for fire emergencies.



(B) Working Wear

▲ CAUTION

● **Wears for safe operation**



Wear a helmet, working clothes, safety shoes and other safety protectors suited to the job. It is especially important to wear well-fitting work clothes.

[Failure to Observe]

A serious accident such as trapping by a machine may occur.

(C) Tools to be Used

▲ WARNING

● **Appropriate holding and lifting**

Never operate when the engine is supported with blocks or wooden pieces or only with a jack.

To lift and hold the engine, always use a crane with a sufficient allowance in limit load or a rigid jack.

[Failure to Observe]

A serious accident may occur.

▲ WARNING

● **Use of appropriate tools**

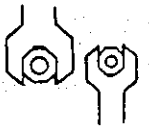

Use tools appropriate for the jobs to be done. Use a correctly sized tool for loosening or tightening a machine part.

[Failure to Observe]

A serious injury or engine damage may occur.

(D) Use of Genuine Parts, Oil and Grease

▲ CAUTION

● **Always use genuine parts.**



[Failure to Observe]

Shortening of engine life or an unexpected accident may arise.

(E) Bolt and Nut Tightening Torque

▲ WARNING

● **Always tighten to the specified torque if designated in the manual.**

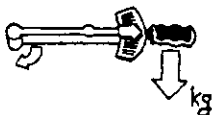

[Failure to Observe]

Loosening or falling may cause parts damage or injury.

(F) Electrical Parts

⚠ WARNING

● Harness short-circuit

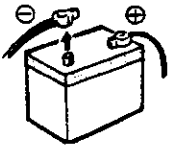

Disconnect the battery negative (-) terminal before starting the service job.

[Failure to Observe]

Short-circuiting of a harness may occur to start a fire.

⚠ WARNING

● Battery charging



Since flammable gas is generated during battery charging, keep anything which could cause a fire away from the battery.

[Failure to Observe]

Explosions may occur.

⚠ WARNING

● Battery electrolyte



Since the electrolyte is diluted sulfuric acid, do not let it be splashed onto the clothes or skin.

[Failure to Observe]

The clothes or skin may be burnt.

(G) Waste Treatment

⚠ CAUTION

Observe the following instructions with regard to waste disposal. Negligence of each instruction will cause environmental pollution.

- Waste fluids such as engine oil and cooling water shall be discharged into a container without spillage onto the ground.
- Do not let waste fluids be discharged into the sewerage, a river or the sea.
- Harmful wastes such as oil, fuel, solvents, filter elements and battery shall be treated according to the respective laws and regulations. Ask a qualified collecting company for example.

(H) Handling the Product

▲ WARNING

● **Supplying the Fuel**



When supplying the fuel, always keep any fire source like a cigarette or match away.

[Otherwise]

A fire or explosion may arise.

▲ WARNING

● **Pay attention to hot portions.**



Do not touch the engine during running or immediately after it is stopped.

[Failure to Observe]

Scalding may be caused by a high temperature.

▲ WARNING

● **Pay attention to rotating parts.**



Never allow clothes or a tool too close to the rotating part during engine running.

[Failure to Observe]

Injury may be caused by entrapping.

CHAPTER 1

GENERAL

1. Exterior Views.....	1-1
2. Specifications.....	1-2
3. Service Standards.....	1-3
4. Performance Curves.....	1-5
5. Dimensions.....	1-6
6. Piping Diagrams.....	1-7
7. Electrical Diagrams.....	1-8

1. Exterior Views

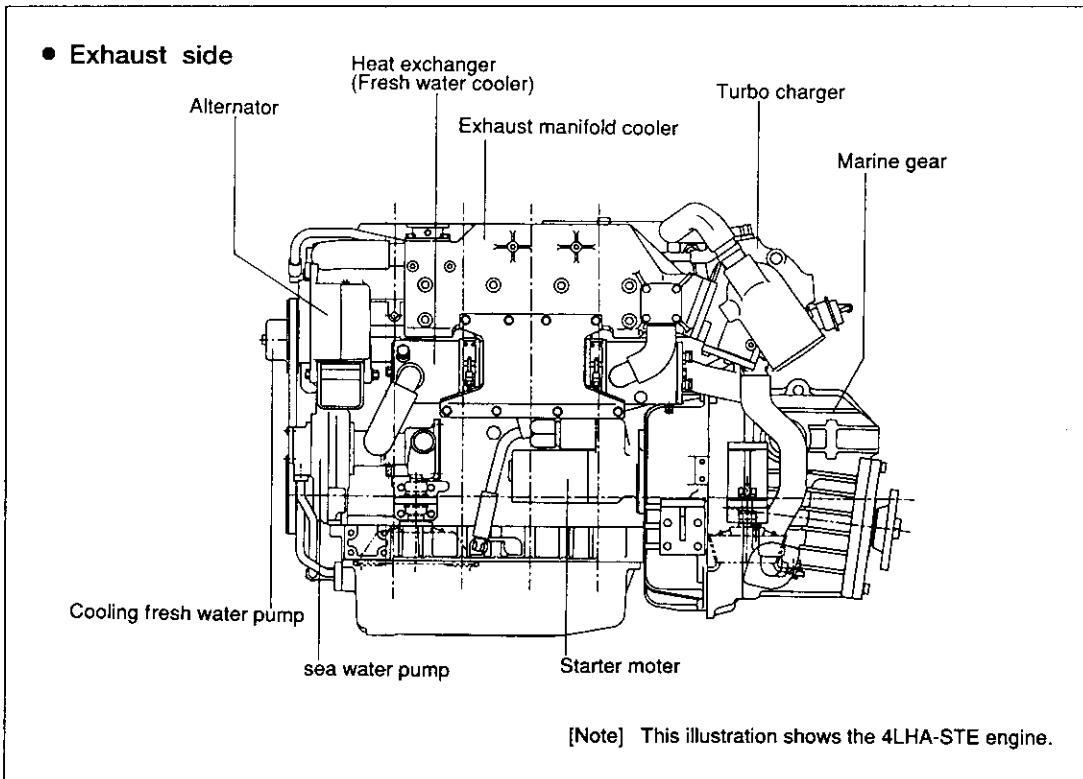
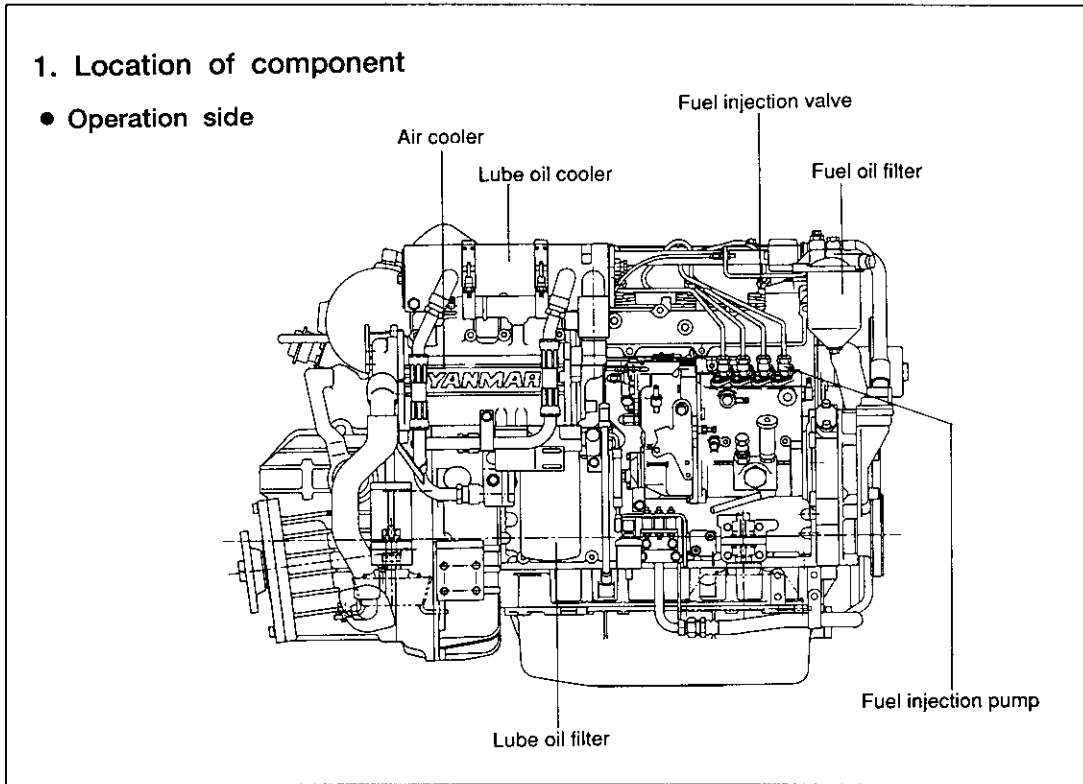

● Operation side

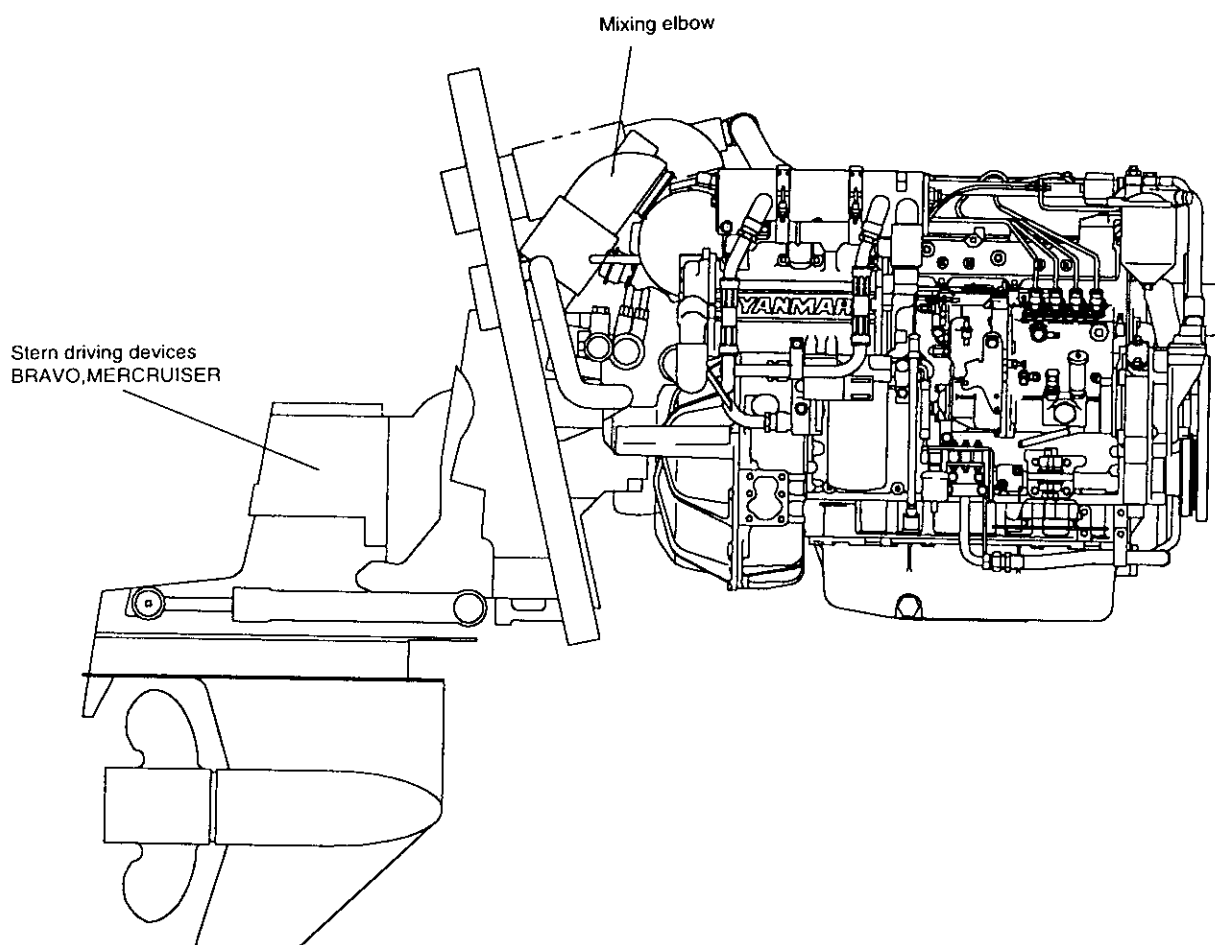

[Note] This illustration shows the
4LHA STZE engine.
(Engine parts are the same)
with 4LHA-STE

2. Specifications

Engine Model			4LHA-STZE	4LHA-STE
Type			Vertical 4-cycle water cooled diesel engine	
Combustions system			Direct injection	
Aspiration			Turbocharger with air cooler	
Number of cylinders			4	
Bore×stroke		mm (in.)	100×110(3.94×4.33)	
Displacement		ℓ (cu.in.)	3.455(210.82)	
One hour rating output (DIN6270B)	Output /crankshaft speed	kW/rpm (HP/rpm)	169 / 3300 (230 / 3300)	
	Brake mean effective pressure	kg/cm ² (lb/in ²)	18.2 (258.44)	
	Piston speed	m/sec(ft/sec)	12.10(39.70)	
Continuous rating output (DIN6270A)	Output /crankshaft speed	kW/rpm (HP/rpm)	140 / 3100 (190 / 3100)	
	Brake mean effective pressure	kg/cm ² (lb/in ²)	16.0 (227.2)	
	Piston speed	m/sec(ft/sec)	11.0(36.09)	
Compression ratio			15.2	
Fire order			180° 180° 180° 180° 1 - 3 - 4 - 2 - 1	
Fuel injection pump			Inline type, YPES-4AL	
Fuel injection timing (b.T.D.C)		degree	13° ± 1°	
Fuel injection pressure		kg/cm ² (lb/in ²)	270 $\begin{smallmatrix} +10 \\ -0 \end{smallmatrix}$ (3840.3 +142.2) -0	
Fuel injection nozzles			Hole type model YDLLA-PL	
Direction of rotation	Crankshaft		Counter-clockwise viewed from stem	
	Propeller shaft		Clockwise or counter clockwise	
Power take off			Full power flywheel side	
Cooling system			Fresh water : Centrifugal pump Sea-water : Rubber impeller pump	
Lubrication system			Forced lubrication with trochoid pump (2pump type)	
Starting system	Starting motor		DC 12V,2.5kW	
	AC generator		12V,55A	
Turbo-charger	Type		RHC61W (IHI make)	
	cooling system		Water cooling	
Air cooler System		Type	Sea-water cooled, plate fin type	
Lubricating oil capacity min./max.		ℓ (quart)	5/13(5.29/13.74)	
Cooling water capacity (Fresh water)	Fresh water tank		ℓ (quart)	
	Sub tank		ℓ (quart)	
Engine lube oil requirment			A.P.I CD Class	
Fuel recomended			Diesel fuel Cetane value :over 45	
Fresh water capacity		ℓ (quart)	Engine:15 Sub tank:0.8	
Idle speed Low/High		rpm	750/3700	

Engine Model		4LHA-STZE			4LHA-STE	
Marine gear system	Model	MERCUSER			HURTH-HSW630A1	
		Bravo 1	Bravo 2	Bravo 3		
	Reduction(Forward/Reverse)		1.36/1.36	1.50/1.50	1.36/1.36	1.22/1.21
			1.50/1.50	1.65/1.65	1.50/1.50	1.56/1.58
			1.65/1.65	1.81/1.81	1.65/1.65	2.04/2.10
	Lube oil requirment	Quick silver high-performance gear lube			ATF II -D	
Lubricating oil capacity min/max	ℓ (quart)	2.0(2.11)	3.0(3.17)	2.0(2.11)	-/3.0(-/3.17)	
Clutch Weight	kg(lb)	88(184)	94(207)	98(216)	44(97)	
Dimensions	Overall length	mm(in.)	1039(40.9)		1059(41.7)	
	Overall width	mm(in.)	714(28.1)		686(27.0)	
	Overall height	mm(in.)	782(30.8)		741(29.2)	
Engine weight with clutch(dry)	kg(lb)	473(1043)	479(1056)	483(1065)	410(904)	

3. Service Standards

		4LHA-STZE·4LHA-STE
Normal Lub. Oil press. At Max. output	Kgf/cm ²	3.5-4.5
Valve clearance in/Ex.	mm	0.1/0.5
Fuel injection timing	deg.	b.T.D.C.14
Fuel injection pressure	Kgf/cm ²	260-270

Tightening torque of bolts and nuts

Unit:kg5 · m

	Bolt & Nut size	Tightening Torque	Wrench
		4LHA-STZE·4LHA-STE	
Cylinder head bolt	M13×1.5	1st:11	17mm
		2nd:17	
		3rd:19	
Connecting rod bolt	M11×1.0	11.5-12.5	17mm
Main bearing cap bolt	M14×1.5	19-21	19mm
Crank shaft V-pulley clamp bolt	M14×1.5	11-13	—
Flywheel clamp bolt	M14×1.5	19-21	—
Fuel injection nozzle clamp nut	M6×1.0	0.6-0.7	—
Fuel injection driving gear, clamp nut	M14×1.5	—	—
	M18×1.5	12-14	

4. Performance Curve

4LHA-STE

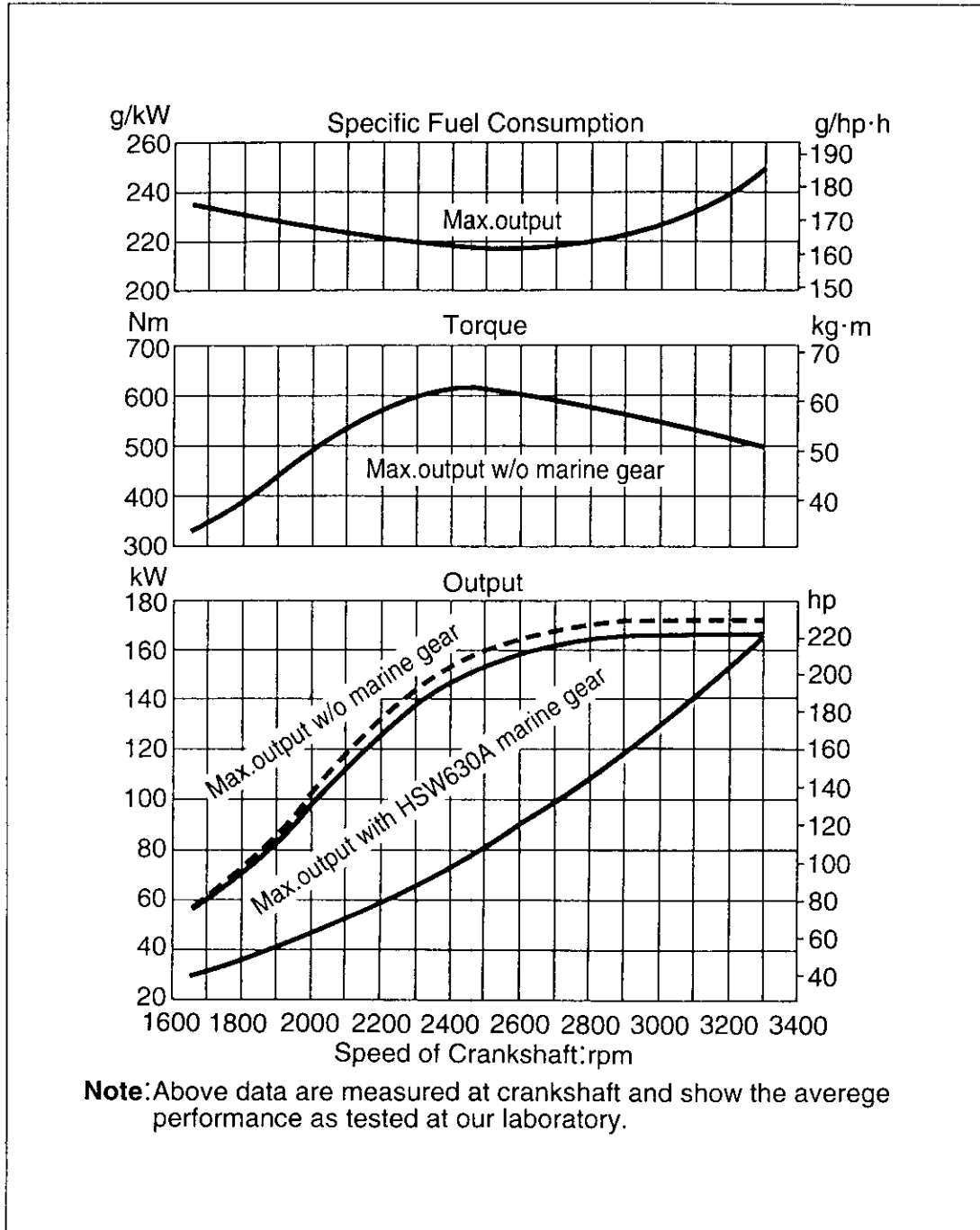

4LHA-STZE

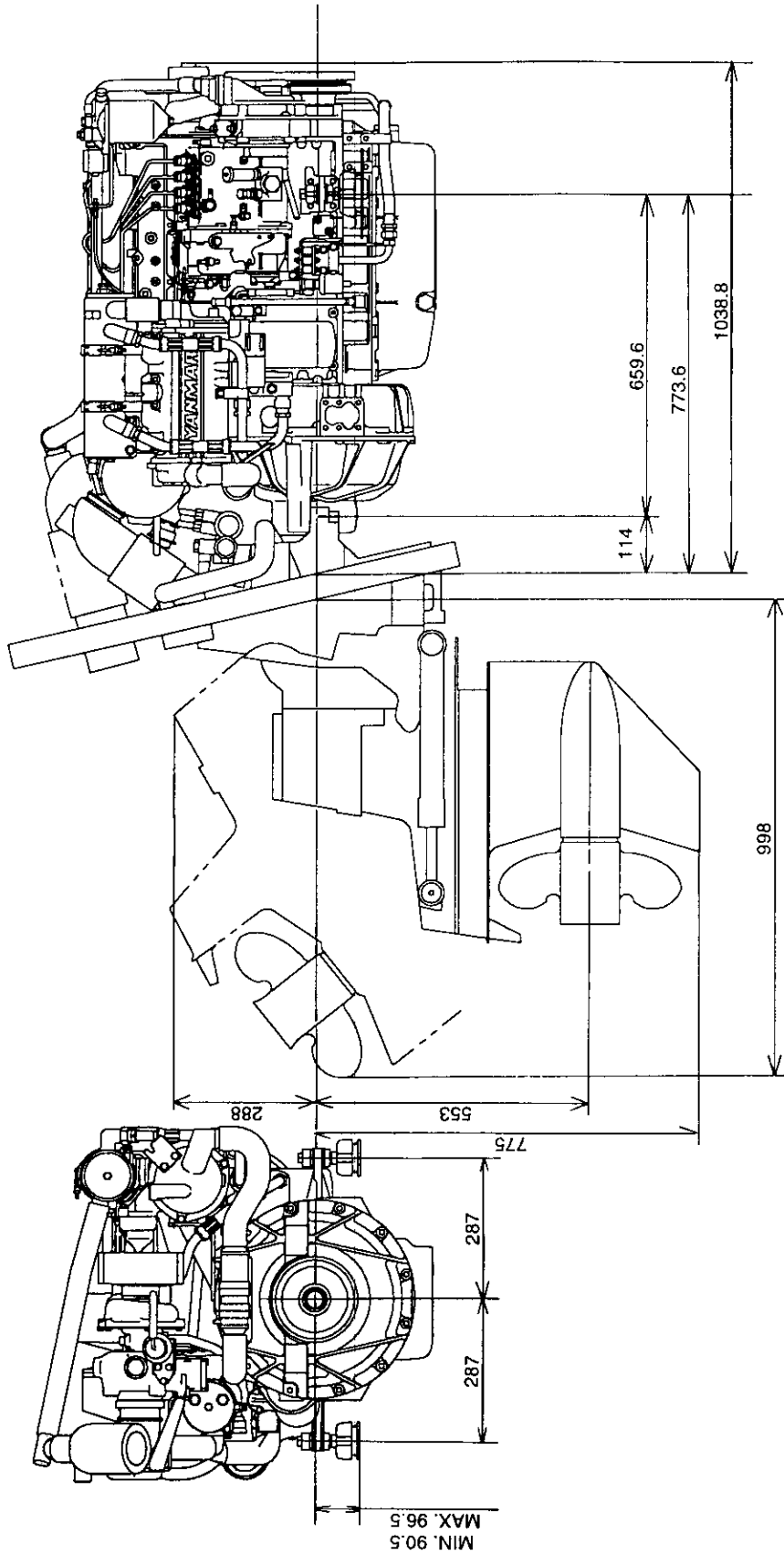

[NOTE] Dimensions of the engine are the same with 4LHA-STE

6. Piping Diagrams

4LHA-STE

MARKS OF PIPING	NAME
	(UNION) SCREW JOINT
	FLANGE JOINT
	EYE JOINT
	INSERTION JOINT
	DRILL HOLE
	COOLING FRESH WATER PIPING
	COOLING SEA WATER PIPING
	LUB. OIL PIPING
	FUEL OIL PIPING

