

**YANMAR®**

M2215-04E140

---

**YANMAR®**

---

**SERVICE MANUAL**

---

**SAIL DRIVE UNIT**

---

**SD40/SD40-4T**

**SD50/SD50-4T**

---

**YANMAR CO.,LTD.**



# CONTENTS

1 General .....	1
1.1 Specifications .....	1
1.2 Exterior view .....	2
1.3 Sectional view .....	3
1.4 Criteria for replacing parts .....	4
1.5 Route of cooling water and lubricating oil .....	5
1.6 Lubricating oil .....	6
1.7 Disassembly and reassembly .....	7
1.8 Special tools .....	14
1.9 Notes on disassembly, inspection and reassembly .....	19
2 Disassembly .....	20
2.1 Disassembling the upper case .....	20
2.1.1 Removal of the unit .....	20
2.1.2 Disassembling the unit .....	27
2.2 Disassembling the lower case .....	32
2.2.1 Removal of unit .....	32
3 Reassembly .....	38
3.1 Reassembling the bearing for lower case .....	38
3.1.1 Needle bearing .....	38
3.1.2 Taper roller bearing outer race .....	38
3.2 Reassembling the bearings of shaft .....	39
3.2.1 Propeller shaft .....	39
3.2.2 Drive shaft .....	39
4 Shim adjustment (Gear backlash adjustment) .....	40
4.1 Location of adjustment shims .....	40
4.2 Measurement of the dimensions of the cases .....	41
4.2.1 Upper case .....	41
4.2.2 Lower case .....	41
4.3 Shim selection method for the clutch shaft .....	42
4.3.1 Measurement of the dimensions (L1, L2, L3) of the gear .....	42
4.3.2 Calculation of the shim thickness .....	43
4.4 Shim selection method for the pinion shaft .....	44
4.4.1 Measurement of the pinion dimensions .....	44
4.4.2 Calculation of the shim thickness .....	44
4.5 Shim selection method for the drive shaft .....	45
4.5.1 Measurement of the dimensions (M1) of the pinion .....	45
4.5.2 Calculation of the shim thickness .....	45

4.6 Shim selection method for the propeller shaft .....	46
4.6.1 Measurement of the dimensions (M3) of the gear .....	46
4.6.2 Calculation of the shim thickness .....	46
5 Adjustment of bearing assembly gap .....	47
5.1 Upper gear bearing .....	47
5.1.1 Measurement of the dimension (L6) of the bearing .....	47
5.1.2 Calculation of the shim thickness .....	47
5.2 Pinion shaft bearing .....	48
5.2.1 Measurement of the dimension (L4) of the bearing .....	48
5.2.2 Calculation of the shim thickness .....	48
5.3 Pinion drive shaft bearing .....	49
5.3.1 Measurement of the dimension (M2) of the bearing .....	49
5.3.2 Calculation of the shim thickness .....	49
5.4 Propeller shaft bearing .....	50
5.4.1 Measurement of the dimension (M4) of the bearing .....	50
5.4.2 Calculation of the shim thickness .....	50
6 Adjustment of the gear backlash .....	51
6.1 Upper gear .....	51
6.2 Lower gear .....	52
7 Adjustment of the gear dye pattern .....	53
7.1 Upper gear .....	53
7.2 Propeller shaft .....	54
8 Adjustment of the shift lever .....	55
8.1 Measurement of the dimensions (H, A) .....	55
8.1.1 Shift Lever bolt .....	55
8.1.2 Shifter pin position .....	55
8.2 Calculation of the shim thickness .....	56
8.3 Caution of reassembly .....	56
9 Tightening torque for nuts and bolts .....	57

# FOR SAFETY

## 1. SAFETY LABELS

- Most accidents are caused by negligence of basic safety rules and precautions. For accident prevention, it is important to avoid such causes before development to accidents.  
Please read this manual carefully before starting repair or maintenance to fully understand safety precautions and appropriate inspection and maintenance procedures.  
Attempting at a repair or maintenance job without sufficient knowledge may cause an unexpected accident.
- It is impossible to cover every possible danger in repair or maintenance in the manual. Sufficient consideration for safety is required in addition to the matters marked  . Especially for safety precautions in a repair or maintenance job not described in this manual, receive instructions from a knowledgeable leader.
- Safety marks used in this manual and their meanings are as follows:



**DANGER**-indicates an imminent hazardous situation which, if not avoided, WILL result in death or serious injury.



**WARNING**-indicates a potentially hazardous situation which, if not avoided, COULD result in death or serious injury.



**CAUTION**-indicates a potentially hazardous situation which, if not avoided, may result in minor or moderate injury.

- **NOTICE** - indicates that if not observed, the product performance or quality may not be guaranteed.

## 2. Safety Precautions

### (1) SERVICE AREA

#### **WARNING**



- **Sufficient Ventilation**

Inhalation of exhaust fumes and dust particles may be hazardous to ones health. Running engines welding, sanding, painting, and polishing tasks should be only done in well ventilated areas.

#### **CAUTION**

- **Safe / Adequate Work Area**

The service area should be clean, spacious, level and free from holes in the floor, to prevent "slip" or "trip and fall" type accidents.

#### **CAUTION**

- **Clean, orderly arranged place**

No dust, mud, oil or parts should be left on the floor surface.  
[Failure to Observe]  
An unexpected accident may be caused.

#### **CAUTION**



- **Bright, Safely Illuminated Area**

The work area should be well lit or illuminated in a safe manner. For work in enclosed or dark areas, a "drop cord" should be utilized. The drop cord must have a wire cage to prevent bulb breakage and possible ignition of flammable substances.

#### **CAUTION**



- **Safety Equipment**

Fire extinguisher(s), first aid kit and eye wash / shower station should be close at hand (or easily accessible) in case of an emergency.

## (2) WORK - WEAR (GARMENTS)

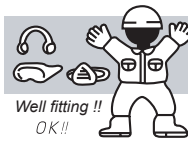

### • Safe Work Clothing

Appropriate safety wear (gloves, special shoes/boots, eye/ear protection, head gear, harness', clothing, etc.) should be used/worn to match the task at hand. Avoid wearing jewelry, unbuttoned cuffs, ties or loose fitting clothes around moving machinery. A serious accident may occur if caught in moving/rotating machinery.

## (3) TOOLS



### • Appropriate Lifting / Holding

When lifting an engine, use only a lifting device (crane, jack, etc.) with sufficient lifting capacity. Do not overload the device. Use only a chain, cable, or lifting strap as an attaching device. Do not use rope, serious injury may result.

To hold or support an engine, secure the engine to a support stand, test bed or test cart designed to carry the weight of the engine. Do not overload this device, serious injury may result.

Never run an engine without being properly secured to an engine support stand, test bed or test cart, serious injury may result.

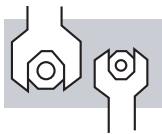

### • Appropriate Tools

Always use tools that are designed for the task at hand. Incorrect usage of tools may result in damage to the engine and or serious personal injury.

## (4) GENUINE PARTS and MATERIALS



### • Genuine Parts

Always use genuine YANMAR parts or YANMAR recommended parts and goods. Damage to the engine, shortened engine life and or personal injury may result.

## (5) FASTENER TORQUE

### WARNING

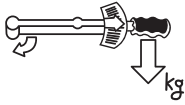

#### • Torquing Fasteners

Always follow the torque values and procedures as designated in the service manual. Incorrect values, procedures and or tools may cause damage to the engine and or personal injury.

## (6) Electrical

### WARNING

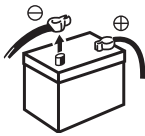

#### • Short Circuits

Always disconnect the (-) Negative battery cable before working on the electrical system. An accidental "short circuit" may cause damage, fire and or personal injury. Remember to connect the (-) Negative battery cable (back onto the battery) LAST

### WARNING



#### • Charging Batteries

Charging wet celled batteries produces hydrogen gas. Hydrogen gas is extremely explosive. Keep sparks, open flame and any other form of ignition away. Explosion may occur causing severe personal injury.

### WARNING



#### • Battery Electrolyte

Batteries contain sulfuric acid. Do NOT allow it to come in contact with clothing, skin and or eyes, severe burns will result.

## (7) WASTE MANAGEMENT

### CAUTION

Observe the following instructions with regard to hazardous waste disposal. Negligence of these will have a serious impact on environmental pollution concerns.

- 1) Waste fluids such as lube oil, fuel and coolant shall be carefully put into separate sealed containers and disposed of properly.
- 2) Do NOT dispose of waste materials irresponsibly by dumping them into the sewer, overland or into natural waterways.
- 3) Waste materials such as oil, fuel, coolant, solvents, filter elements and batteries, must be disposed of properly according to local ordinances. Consult the local authorities or reclamation facility.



## (8) FURTHER PRECAUTIONS

### **WARNING**



#### • Fueling / Refueling

Keep sparks, open flames or any other form of ignition (match, cigarette, etc.) away when fueling/refueling the unit. Fire and or an explosion may result.

### **WARNING**



#### • Hot Surfaces.

Do NOT touch the engine (or any of its components) during running or shortly after shutting it down. Scalding / serious burns may result. Allow the engine to cool down before attempting to approach the unit.

### **WARNING**



#### • Rotating Parts

Be careful around moving/rotating parts. Loose clothing, jewelry, ties or tools may become entangled causing damage to the engine and or severe personal injury.

### **WARNING**



#### • Preventing burns from scalding

- 1) Never open the filler cap shortly after shutting the engine down. Steam and hot water will spurt out and seriously burn you. Allow the engine to cool down before attempt to open the filler cap.
- 2) Securely tighten the filler cap after checking the cooling water. Steam can spurt out during engine running, if tightening loose.

### **CAUTION**

#### • Safety Label Check

Pay attention to the product safety label.

A safety label (caution plate) is affixed on the product for calling special attention to safety.

If it is missing or illegible, always affix a new one.

### 3. Precautions for Service Work

#### (1) Precautions for Safety

Read the safety precautions given at the beginning of this manual carefully and always mind safety in work.

#### (2) Preparation for Service Work

Preparation is necessary for accurate, efficient service work. Check the customer ledger file for the history of the engine.

- Preceding service date
- Period/operation hours after preceding service
- Problems and actions in preceding service
- Replacement parts expected to be required for service
- Recording form/check sheet required for service

#### (3) Preparation before Disassembly

- Prepare general tools, special service tools, measuring instruments, oil, grease, non-reusable parts, and parts expected to be required for replacement.
- When disassembling complicated portions, put match-marks and other marks at places not adversely affecting the function for easy reassembly.

#### (4) Precautions in Disassembly

- Each time a parts is removed, check the part installed state, deformation, damage, roughening, surface defect, etc.
- Arrange the removed parts orderly with clear distinction between those to be replaced and those to be used again.
- Parts to be used again shall be washed and cleaned sufficiently.
- Select especially clean locations and use clean tools for disassembly of hydraulic units such as the fuel injection pump.

#### (5) Precautions for Inspection and Measurement

Inspect and measure parts to be used again as required to determine whether they are reusable or not.

#### (6) Precautions for Reassembly

- Reassemble correct parts in correct order according to the specified standards (tightening torques, and adjustment standards). Apply oil important bolts and nuts before tightening when specified.
- Always use genuine parts for replacement.
- Always use new oil seals, O-rings, packing and cotter pins.
- Apply sealant to packing depending on the place where they are used. Apply of grease to sliding contact portions, and apply grease to oil seal lips.

#### (7) Precautions for Adjustment and Check

Use measuring instruments for adjustment to the specified service standards.

# 1 General

## 1.1 Specifications

Item		Unit	Contents				
Model			SD40-3, SD50-3	SD40-4, SD50-4	SD40-4T, SD50-4T		
Clutch system			Cone clutch				
Reduction gear system			Bevel gear				
Direction of rotation	Input shaft		Counter-clockwise viewed from stern				
	Propeller shaft		Counter-clockwise or clockwise viewed from stern				
Reduction ratio	Ahead		2.32				
	Astern		2.32				
Lubrication system			Splash lubrication				
Lub.oil capacity		L	2.2 (SD40 old type 1.8)				
Dry mass		kg	39			41	
Applicable eng.	Model		3JH3CE	3JH4CE	4JH3CE	4JH4CE	4JH3-TCE
	Output (DIN6270B)	kW (PS)	29.4(40)/3800	29.4(40)/3000	41.2(56)/3800	40.5(55)/3000	55.2(75)/3800
Allowable torque		N•m (kgf•m)	129(13.1)			140(14.3)	
Allowable speed at Input shaft		min <sup>-1</sup> (rpm)	4000				
Lube oil			API service grade GL4 or higher,SAE80W-90 or 90(High performance gear lube, as shown on the right, is also acceptable.)			Quicksilver high performance gear lube.	
Max. propeller dia.		mm (inch)	457(18)				
Mounting size			SAE #5			SAE #4	
Sealing method for bottom of ship			Double				
Engine installation direction			180° Acceptable				

Quicksilver<sup>®</sup> is registered trademark of Brunswick Corporation.

## 1.2 Exterior view

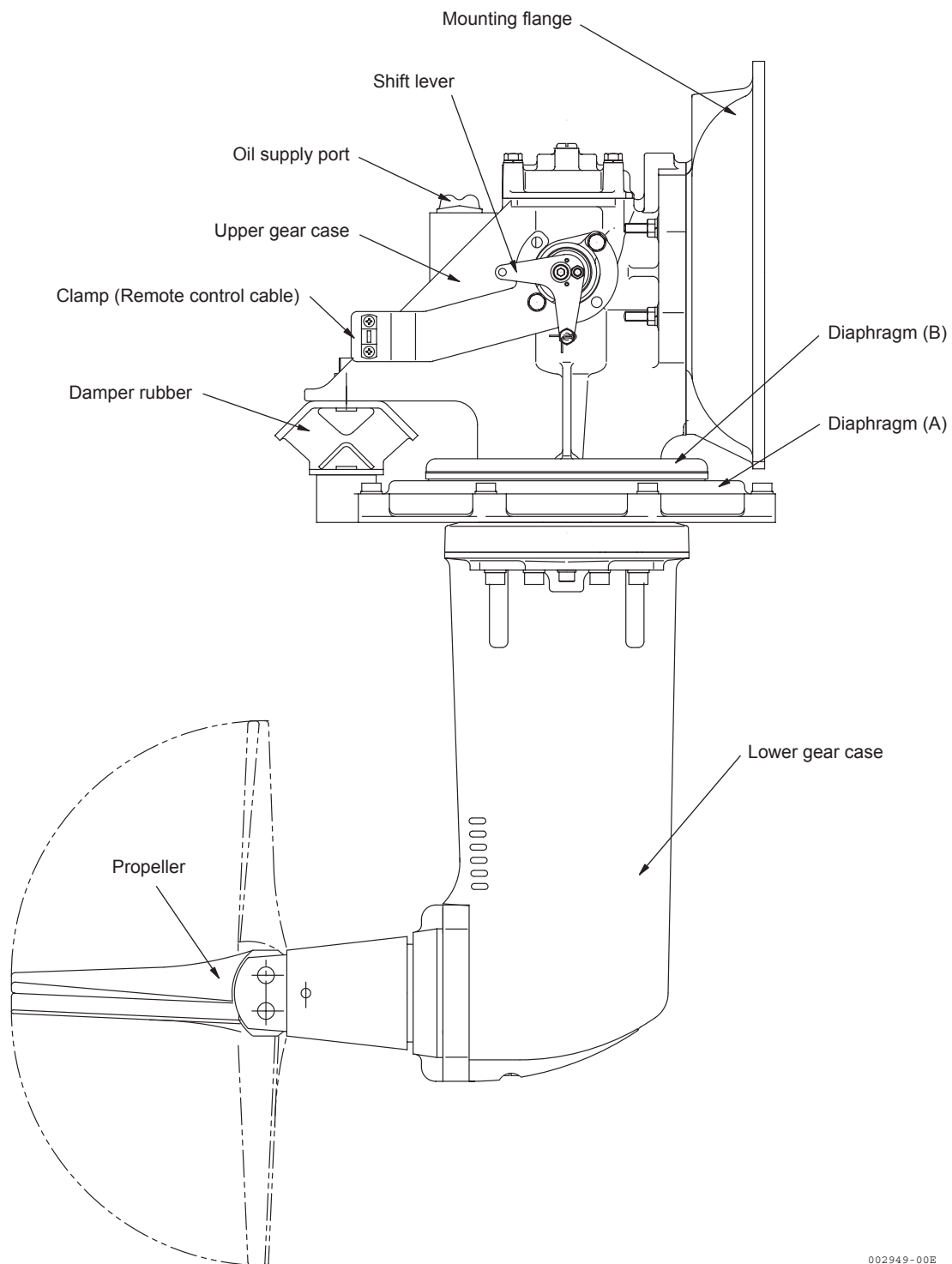

### 1.3 Sectional view

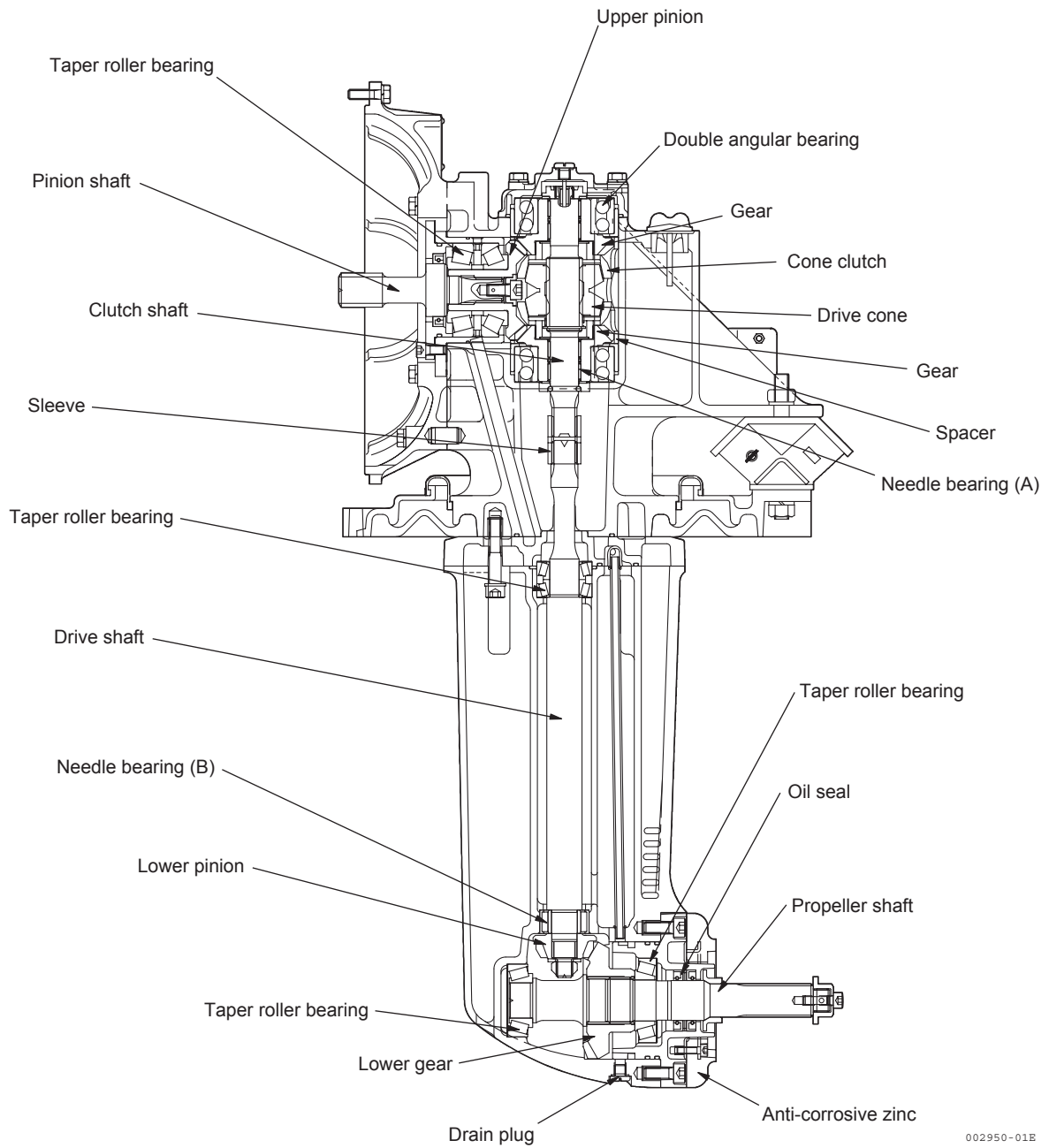

## 1.4 Criteria for replacing parts

		Criteria for replacement	
		Standard value	Standard service life
Bearing	Needle bearing (A) (K24 x 28 x 17)	Evidence of needle flaking or loss	Every 1500 hours
	Needle bearing (B)		
Anti-corrosive zinc		Weight : $\leq 400$ g (with plug)	A half year or less than 1/2 of its original size
Oil seals		1) Lip hardening or hair cracks 2) Disassembly	Every 1000 hours or 2 years
O-ring		Disassembly	
Diaphragms (A) & (B)		Hair cracks	2 years
Steel band		Disassembly	

### 1.5 Route of cooling water and lubricating oil

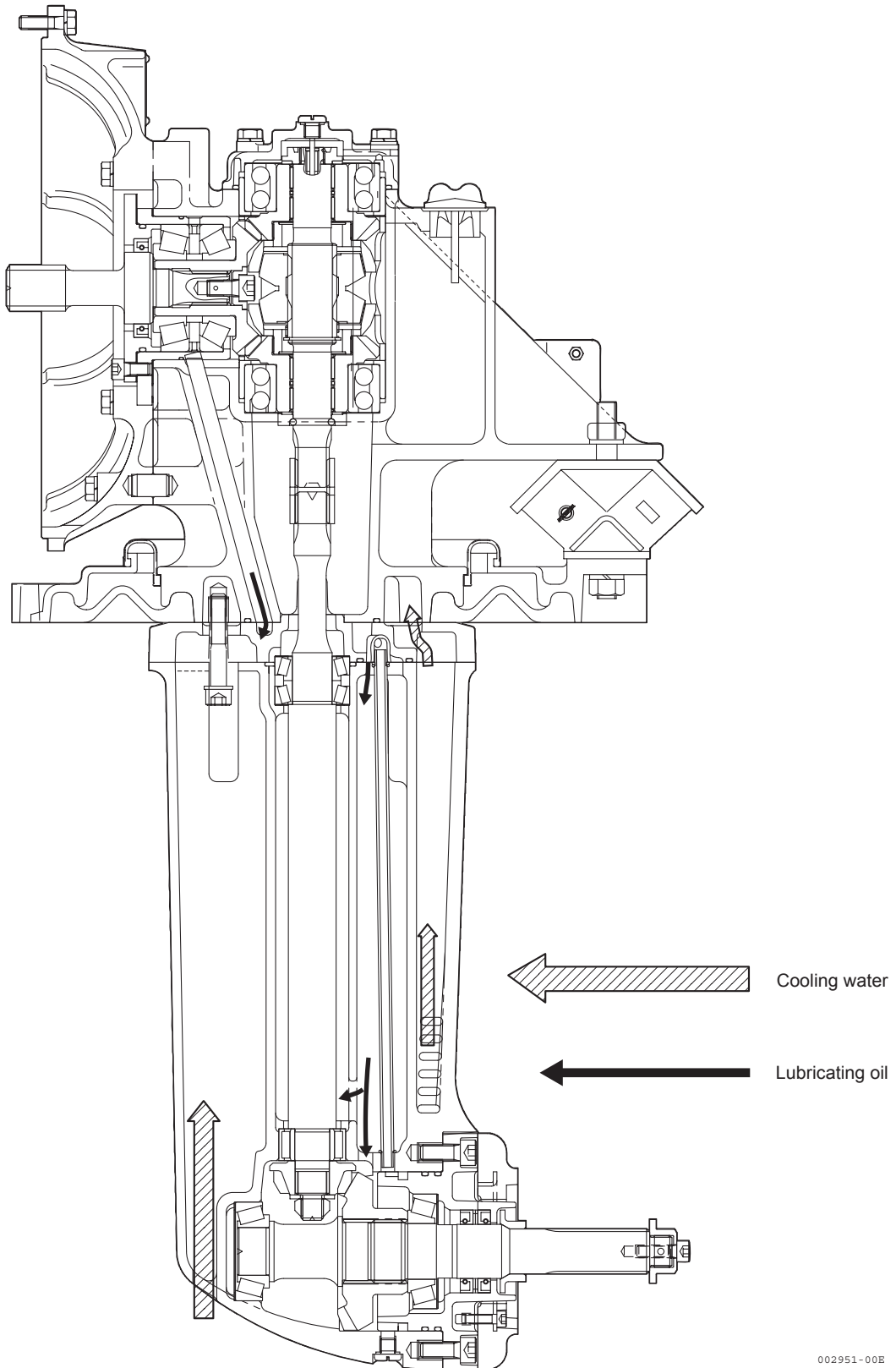

## 1.6 Lubricating oil

### (1) Choice of lube oil

The selection of lube oil is very important to a Sail-drive. If an unsuitable oil is used, or oil change is neglected, it may result in damage and a shorter Sail-drive life. When selecting the lube oil, it must be one of the following.

### (2) Kind of lube oil

See 1.2 specifications.

### (3) Lube oil viscosity

The viscosity of the lube oil greatly influences Sail-drive performance.

SD40, SD50			
Supplier	Brand name	API service	SAE No.
SHELL	Shell Spilax oil EP 90	GL-4	90
SHELL	Shell Spilax oil HD 90	GL-5	90
CALTEX	Multipurpose thuban EP	GL-4, GL-5	90
MOBIL	Mobilub HD 80W-90	GL-5	80W-90
ESSO	Esso gear oil GP 90	GL-4	90
ESSO	Esso gear oil GP 90	GL-5	90
SD40-4T, SD50-4T			
Quicksilver <sup>®</sup>	High performance gear lube		

Quicksilver<sup>®</sup> is registered trademark of Brunswick Corporation.





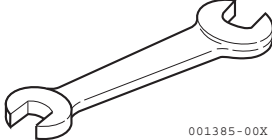
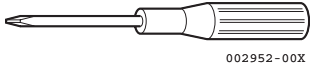
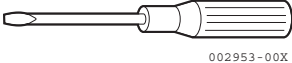
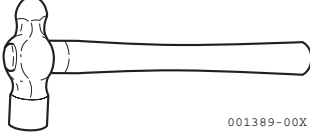
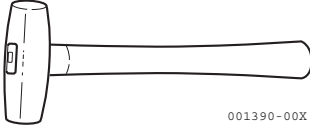
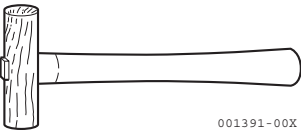

## 1.7 Disassembly and reassembly

The following tools are necessary when disassembling and reassembling the sail drive unit. These tools must be used according to disassembly process and location.

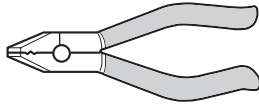
### General hand tools

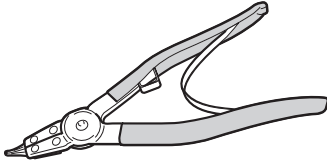
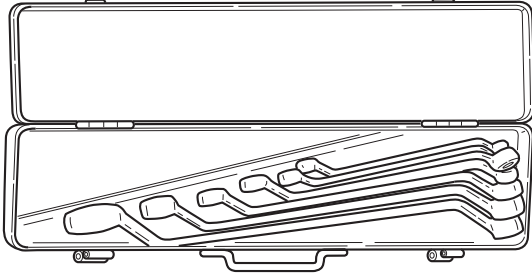
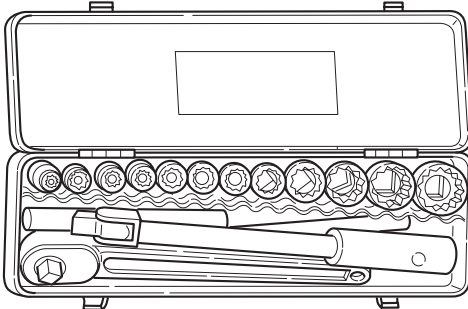
Name	Illustration	Remarks
Spanner		10 x 13 12 x 14 17 x 19 21 x 23 21 x 24
Screwdriver for + (Cross recessed head) screws		
Screwdriver for – (Philips head) screws		
Steel hammer		
Copper hammer		
Mallet		

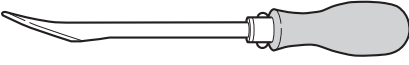
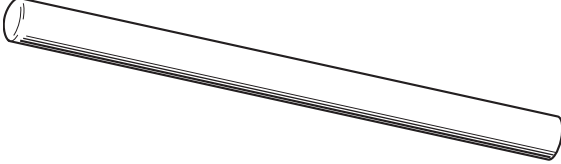
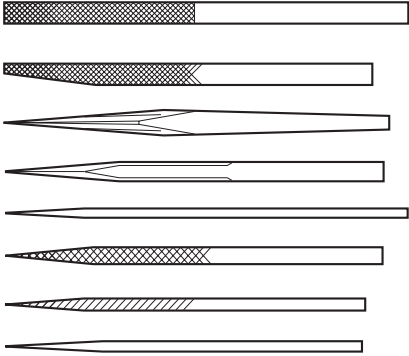
Name	Illustration	Remarks
Nipper	 <p data-bbox="890 421 975 439">001392-00X</p>	
Plier	 <p data-bbox="900 613 984 631">001393-00X</p>	
Starting plier	 <p data-bbox="927 893 1011 911">003262-00X</p>	
Offset wrench	 <p data-bbox="1027 1350 1112 1368">001394-00X</p>	1set
Box spanner	 <p data-bbox="1002 1888 1086 1906">001395-00X</p>	1set

Name	Illustration	Remarks
Scrapper	 <p>001396-00X</p>	
Lead rod	 <p>001397-00X</p>	
File	 <p>001398-00X</p>	1set
Rod spanner for hexagon socket head screws (L-type)	 <p>001399-00X</p>	5 mm 6 mm 8 mm
Rod spanner for hexagon socket head screws (Straight type)	 <p>002954-00X</p>	5 mm 6 mm 8 mm

**Measuring instruments**

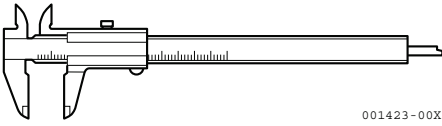
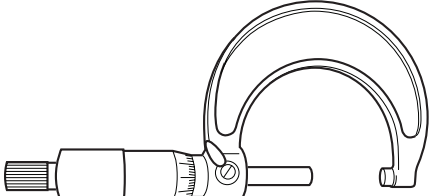
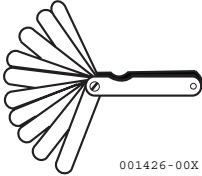
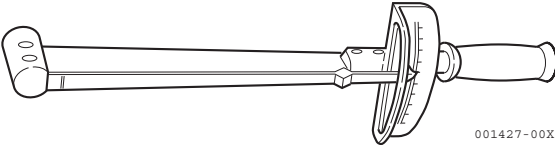
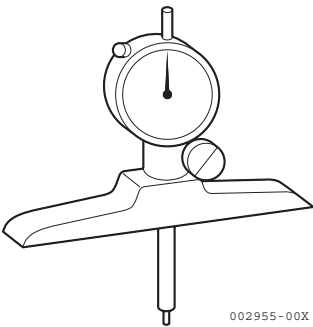
Name	Illustration	Accuracy & range	Ref.
Vernier calipers	 <p>001423-00X</p>	1/20 mm, 0-150 mm	
Micrometer	 <p>001424-00X</p>	1/100 mm, 0-25 mm, 25-50 mm, 100-125 mm	
Thickness gauge	 <p>001426-00X</p>	0.05-2 mm	
Torque wrench	 <p>001427-00X</p>	0-147 N-m (0-15 kgf-m)	
Dial depth gauge	 <p>002955-00X</p>	1/100 mm, 0-150 mm	8.1.2