

F225A
FL225A

SERVICE MANUAL

290435

69J-28197-3D-11

NOTICE

This manual has been prepared by Yamaha primarily for use by Yamaha dealers and their trained mechanics when performing maintenance procedures and repairs to Yamaha equipment. It has been written to suit the needs of persons who have a basic understanding of the mechanical and electrical concepts and procedures inherent in the work, for without such knowledge attempted repairs or service to the equipment could render it unsafe or unfit for use.

Because Yamaha has a policy of continuously improving its products, models may differ in detail from the descriptions and illustrations given in this publication. Use only the latest edition of this manual. Authorized Yamaha dealers are notified periodically of modifications and significant changes in specifications and procedures, and these are incorporated in successive editions of this manual.

Microsoft and Windows are registered trademarks of Microsoft Corporation.

Important information

Particularly important information is distinguished in this manual by the following notations:

 The Safety Alert Symbol means ATTENTION! BECOME ALERT! YOUR SAFETY IS INVOLVED!

WARNING

Failure to follow WARNING instructions could result in severe injury or death to the machine operator, a bystander, or a person inspecting or repairing the outboard motor.

CAUTION:









A CAUTION indicates special precautions that must be taken to avoid damage to the outboard motor.

NOTE:

A NOTE provides key information to make procedures easier or clearer.

**F225A, FL225A
SERVICE MANUAL
©2001 by Yamaha Motor Co., Ltd.
1st Edition, June 2001
All rights reserved.
Any reprinting or unauthorized use
without the written permission of
Yamaha Motor Co., Ltd.
is expressly prohibited.
Printed in the Netherlands**

Contents

General information		1
	GEN INFO	
Specifications		2
	SPEC	
Periodic checks and adjustments		3
	CHK ADJ	
Fuel system		4
	FUEL	
Power unit		5
	POWR	
Lower unit		6
	LOWR	
Bracket unit		7
	BRKT	
Electrical systems		8
	ELEC	
Troubleshooting		9
	TRBL SHTG	
Index		

General information

How to use this manual	1-1
Manual format.....	1-1
Symbols.....	1-2
Safety while working	1-3
Fire prevention.....	1-3
Ventilation.....	1-3
Self-protection	1-3
Parts, lubricants, and sealants	1-3
Good working practices	1-4
Disassembly and assembly	1-4
Identification	1-5
Applicable models	1-5
Serial number	1-5
Features and benefits	1-6
Newly developed V6 4-stroke engine	1-6
Valve train system	1-9
Intake system	1-11
Exhaust system	1-11
Fuel system	1-13
PTT (Power trim and tilt) unit.....	1-17
Technical tips	1-18
Fuel injection control.....	1-18
Fail-safe function table	1-20
PTT (Power trim and tilt) unit.....	1-21
Cooling system	1-26
Lubrication system.....	1-26
Propeller selection	1-27
Propeller size	1-27
Selection.....	1-27

Predelivery checks	1-28
Checking the fuel system	1-28
Checking the gear oil	1-28
Checking the engine oil	1-28
Checking the battery.....	1-28
Checking the outboard motor mounting height.....	1-29
Checking the remote control cables	1-29
Checking the steering wheel	1-30
Checking the gearshift and throttle operation.....	1-30
Checking the tilt system.....	1-30
Checking the engine start switch and engine stop switch/ engine shut-off switch	1-30
Checking the cooling water pilot hole	1-31
Test run	1-31
Break-in	1-31
After test run	1-31



How to use this manual

Manual format

The format of this manual has been designed to make service procedures clear and easy to understand. Use the information below as a guide for effective and quality service.

- ① Parts are shown and detailed in an exploded diagram and are listed in the components list.
- ② Tightening torque specifications are provided in the exploded diagrams and after a numbered step with tightening instructions.
- ③ Symbols are used to indicate important aspects of a procedure, such as the grade of lubricant and lubrication point.
- ④ The components list consist of parts and part quantities, as well as bolt, screw, O-ring, and hose dimensions.
- ⑤ Service points regarding removal, checking, and installation are shown in individual illustrations to explain the relevant procedure.

NOTE:

For troubleshooting procedures, see Chapter 9, "Troubleshooting."

POWER Power unit

Cylinder head

1st 23 N·m (2.3 kgf·m, 17 ft·lb)
2nd 47 N·m (4.7 kgf·m, 34 ft·lb)

18 N·m (1.8 kgf·m, 13 ft·lb)

1st 6 N·m (0.6 kgf·m, 4.3 ft·lb)
2nd 12 N·m (1.2 kgf·m, 8.7 ft·lb)

5-25 62Y5A11

Cylinder head

No.	Part name	Q'ty	Remarks
1	Cylinder head	1	
2	Oil pump	1	
3	Cylinder head cover	1	
4	Bolt	7	M6 × 20 mm
5	Cylinder head cover gasket	1	Not reusable
6	Bolt	10	M9 × 95 mm
7	Spark plug	4	
8	Bolt	5	M6 × 25 mm
9	Dowel pin	2	
10	Cylinder head gasket	1	Not reusable
11	Grommet	4	
12	Anode	4	
13	Cover	4	

④

POWER Power unit

Removing the timing belt and sprockets

1. Set the cylinder #1 piston position to TDC of the compression stroke by aligning the "1" mark ② on the driven sprocket with the "▲" mark ③ on the cylinder head.

CAUTION:
Do not turn the drive sprocket counterclockwise, otherwise the valve system may be damaged.

2. Remove the breather hose and loosen the drive sprocket nut ①.

3. Remove the tensioner ④ and timing belt ⑤ from the driven sprocket side.

4. Loosen the driven sprocket bolt ⑥ and remove the driven sprocket ⑦.

NOTE:
Do not turn the camshaft when loosening the driven sprocket bolt.

⑤ Flywheel holder: 90890-06522

5. Remove the nut ①, retaining plates ⑧, drive sprocket ⑨, and Woodruff key ⑩.

5-21 62Y5A11

Symbols

The symbols below are designed to indicate the content of a chapter.

General information

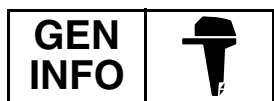

Fuel system

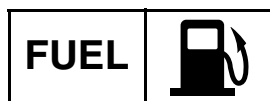

Bracket unit

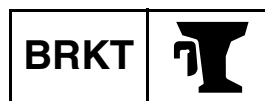

Specifications



Power unit



Electrical systems

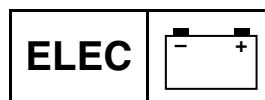

Periodic checks and adjustments



Lower unit

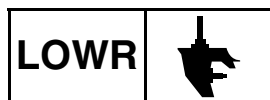

Troubleshooting



Symbols ① to ⑥ indicate specific data.

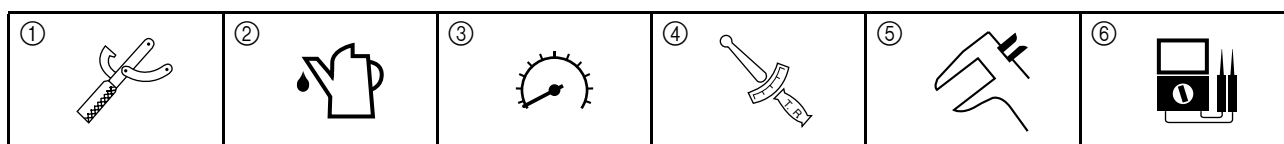

- ① Special tool
- ② Specified oil or fluid
- ③ Specified engine speed
- ④ Specified tightening torque
- ⑤ Specified measurement
- ⑥ Specified electrical value (resistance, voltage, electric current)

Symbols ⑦ to ⑪ in an exploded diagram indicate the grade of lubricant and the lubrication point.

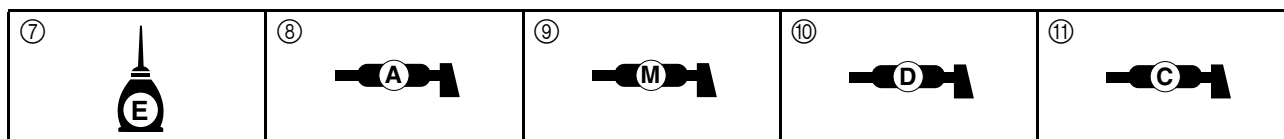

- ⑦ Apply Yamaha 4-stroke motor oil
- ⑧ Apply water resistant grease (Yamaha grease A)
- ⑨ Apply molybdenum disulfide grease
- ⑩ Apply corrosion resistant grease (Yamaha grease D)
- ⑪ Apply low temperature resistant grease (Yamaha grease C)

Symbols ⑫ to ⑰ in an exploded diagram indicate the type of sealant or locking agent and the application point.

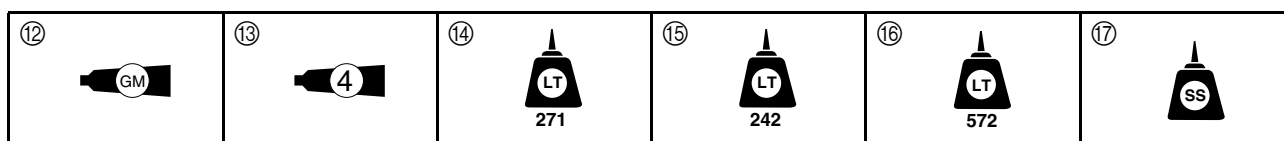

- ⑫ Apply Gasket Maker®
- ⑬ Apply Yamabond No. 4
- ⑭ Apply LOCTITE® No. 271 (Red)
- ⑮ Apply LOCTITE® No. 242 (Blue)
- ⑯ Apply LOCTITE® No. 572
- ⑰ Apply silicon sealant



Safety while working

To prevent an accident or injury and to ensure quality service, follow the safety procedures provided below.

Fire prevention

Gasoline is highly flammable. Keep gasoline and all flammable products away from heat, sparks, and open flames.

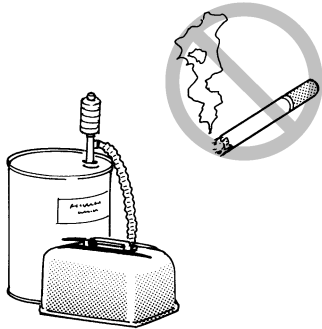

S69J1010

Ventilation

Gasoline vapor and exhaust gas are heavier than air and extremely poisonous. If inhaled in large quantities they may cause loss of consciousness and death within a short time. When test running an engine indoors (e.g., in a water tank) be sure to do so where adequate ventilation can be maintained.

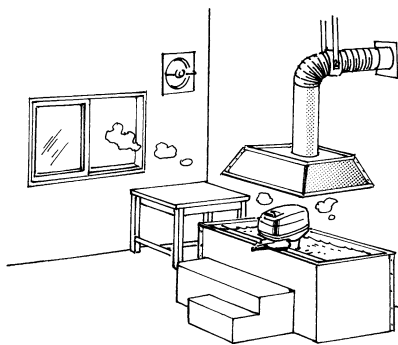

S69J1020

Self-protection

Protect your eyes by wearing safety glasses or safety goggles during all operations involving drilling and grinding, or when using an air compressor.

Protect your hands and feet by wearing protective gloves and safety shoes when necessary.

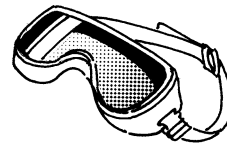

S69J1030

Parts, lubricants, and sealants

Use only genuine Yamaha parts, lubricants, and sealants or those recommended by Yamaha, when servicing or repairing the outboard motor.

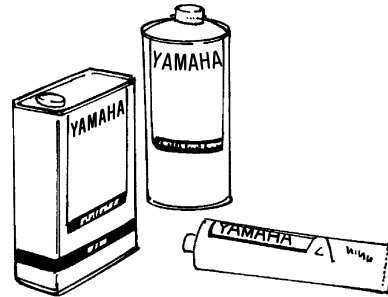

S69J1040

Under normal conditions, the lubricants mentioned in this manual should not harm or be hazardous to your skin. However, you should follow these precautions to minimize any risk when working with lubricants.

1. Maintain good standards of personal and industrial hygiene.
2. Change and wash clothing as soon as possible if soiled with lubricants.
3. Avoid contact with skin. Do not, for example, place a soiled rag in your pocket.
4. Wash hands and any other part of the body thoroughly with soap and hot water after contact with a lubricant or lubricant soiled clothing has been made.
5. To protect your skin, apply a protective cream to your hands before working on the outboard motor.

6. Keep a supply of clean, lint-free cloths for wiping up spills, etc.

Good working practices

Special tools

Use the recommended special tools to protect parts from damage. Use the right tool in the right manner—do not improvise.

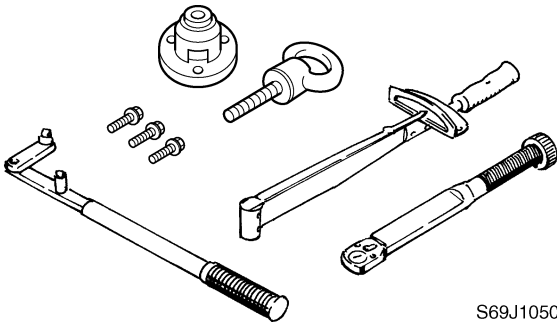

S69J1050

Tightening torques

Follow the tightening torque specifications provided throughout the manual. When tightening nuts, bolts, and screws, tighten the large sizes first, and tighten fasteners starting in the center and moving outward.

Non-reusable parts

Always use new gaskets, seals, O-rings, cotter pins, circlips, etc., when installing or assembling parts.

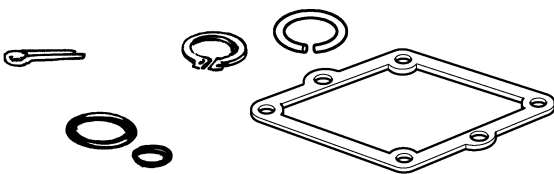

S69J1060

Disassembly and assembly

1. Use compressed air to remove dust and dirt during disassembly.
2. Apply engine oil to the contact surfaces of moving parts before assembly.

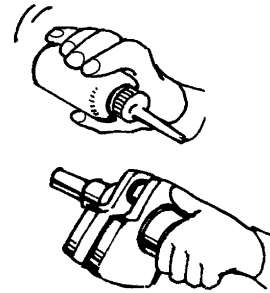

S69J1070

3. Install bearings with the manufacture identification mark in the direction indicated in the installation procedure. In addition, be sure to lubricate the bearings liberally.
4. Apply a thin coat of water-resistant grease to the lip and periphery of an oil seal before installation.
5. Check that moving parts operate normally after assembly.



Identification

Applicable models

This manual covers the following models.

Applicable models
F225AET, FL225AET

Serial number

The outboard motor serial number is stamped on a label attached to the port clamp bracket.

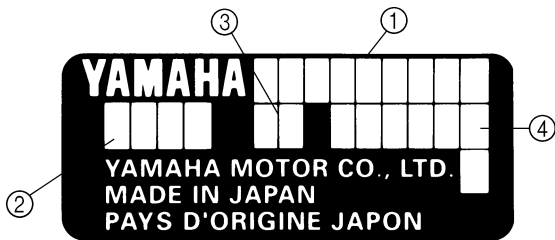
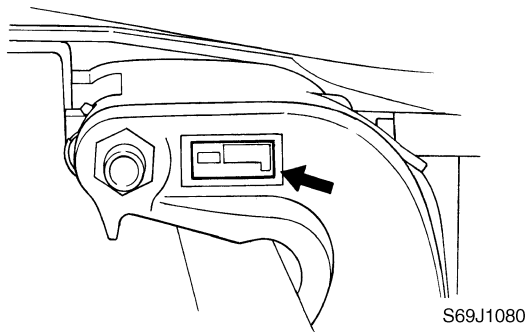

- ① Model name
- ② Approved model code
- ③ Transom height
- ④ Serial number

Model name	Approved model code	Starting serial No.
F225AET	69J	X: 000101–
		U: 150101–
FL225AET	69K	X: 000101–
		U: 100101–