

PREFACE

This manual covers the construction, function and servicing procedures of the Honda BF15D, BF20D Outboard Motors.

All information contained in this manual is based on the latest product information available at the time of printing. We reserve the right to make changes at anytime without notice.

No part of this publication may be reproduced, stored in a retrieval system, or transmitted, in any form, by any means, electronic, mechanical, photocopying, recording, or otherwise, without prior written permission of the publisher. This includes text, figures, and tables.

As you read this manual, you will find information that is preceded by a **NOTICE** symbol. The purpose of this message is to help prevent damage to the outboard motor, other property, or the environment.

SAFETY MESSAGES

Your safety, and the safety of others, are very important. To help you make informed decisions, we have provided safety messages and other safety information throughout this manual. Of course, it is not practical or possible to warn you about all the hazards associated with servicing these outboard motors. You must use your own good judgment.

You will find important safety information in a variety of forms, including:

- **Safety Messages** -- preceded by a safety alert **⚠** symbol and one of three signal words, **DANGER**, **WARNING**, or **CAUTION**.

These signal words mean:

⚠ DANGER You **WILL** be **KILLED** or **SERIOUSLY HURT** if you don't follow instructions.

⚠ WARNING You **CAN** be **KILLED** or **SERIOUSLY HURT** if you don't follow instructions.

⚠ CAUTION You **CAN** be **HURT** if you don't follow instructions.

- **Instructions** -- how to service this outboard motor correctly and safely.

Honda Motor Co., Ltd
Service Publication Office

CONTENTS

SPECIFICATIONS	1
SERVICE INFORMATION	2
MAINTENANCE	3
PROPELLER/GEAR CASE/EXTENSION CASE	4
ENGINE COVERS	5
FUEL SYSTEM	6
RECOIL STARTER	7
ENGINE REMOVAL/INSTALLATION	8
FLYWHEEL/TIMING BELT	9
CYLINDER HEAD/VALVES/OIL PUMP	10
CRANKCASE/CRANKSHAFT/PISTON	11
OIL CASE/STERN BRACKET/SWIVEL CASE	12
SHIFT MECHANISM	13
STEERING ROD/REMOTE CONTROL BOX	14
TILLER HANDLE	15
ELECTRICAL EQUIPMENT	16
WIRING DIAGRAMS	17

1. SPECIFICATIONS	1-1	10. CYLINDER HEAD/VALVES/OIL PUMP	10-1
1. SPECIFICATIONS	1-1	1. CYLINDER HEAD REMOVAL	10-2
2. DIMENSIONAL DRAWINGS	1-4	2. OIL PUMP	10-5
2. SERVICE INFORMATION	2-1	3. CYLINDER HEAD DISASSEMBLY	10-8
1. THE IMPORTANCE OF PROPER SERVICING	2-1	4. VALVE SEAT REFACING	10-14
2. IMPORTANT SAFETY PRECAUTIONS	2-1	5. CYLINDER HEAD ASSEMBLY	10-16
3. SYMBOLS USED IN THIS MANUAL	2-2	6. CYLINDER HEAD INSTALLATION	10-18
4. SERIAL NUMBER LOCATIONS	2-2	11. CRANKCASE/CRANKSHAFT/PISTON	11-1
5. MAINTENANCE STANDARDS	2-3	1. THERMOSTAT/WATER JACKET	11-2
6. TORQUE VALUES	2-6	2. OIL STRAINER	11-8
7. SPECIAL TOOLS	2-9	3. PISTON	11-9
8. TROUBLESHOOTING	2-11	4. CRANKSHAFT/CYLINDER BLOCK	11-15
9. CABLE & HARNESS ROUTING	2-29	12. OIL CASE/STERN BRACKET/SWIVEL CASE	12-1
10. LUBRICATION POINTS	2-41	1. OIL CASE	12-2
3. MAINTENANCE	3-1	2. FRICTION ADJUST LEVER	12-4
1. MAINTENANCE SCHEDULE	3-1	3. MOUNT FRAME	12-6
2. ENGINE OIL	3-2	4. STERN BRACKET	12-7
3. OIL FILTER CARTRIDGE	3-3	5. SWIVEL CASE	12-11
4. GEAR CASE OIL	3-5	13. SHIFT LINKAGE	13-1
5. SPARK PLUG	3-6	1. SHIFT ARM/THROTTLE ARM	13-2
6. VALVE CLEARANCE	3-8	2. SHIFT LEVER	13-3
7. CARBURETOR	3-10	3. SHIFT SHAFT	13-4
8. FUEL FILTER	3-11	14. STEERING ROD/REMOTE CONTROL BOX	14-1
9. FUEL TANK STRAINER	3-12	1. STEERING ROD	14-1
10. FUEL TUBES	3-12	2. REMOTE CONTROL CABLE	14-2
11. THROTTLE LINKAGE	3-13	3. CONTROL BOX WIRE HARNESS	14-4
12. TIMING BELT	3-15	4. REMOTE CONTROL BOX	14-5
13. CRANKCASE BREATHER	3-19	15. TILLER HANDLE	15-1
14. EXHAUST EMISSION (Bodensee model)	3-19	1. TILLER HANDLE	15-2
4. PROPELLER/GEAR CASE/EXTENSION CASE	4-1	2. TILLER HANDLE BRACKET	15-6
1. PROPELLER	4-2	3. THROTTLE GRIP	15-7
2. PROPELLER SHAFT HOLDER	4-3	4. STARTER SWITCH	15-11
3. GEAR CASE ASSEMBLY	4-9	5. EMERGENCY STOP SWITCH	15-12
4. WATER PUMP	4-11	16. ELECTRICAL EQUIPMENT	16-1
5. VERTICAL SHAFT/BEVEL GEAR	4-15	1. STARTER MOTOR	16-1
6. WATER PUMP HOUSING	4-21	2. STARTER CABLE (Type with 12A charge coil)	16-13
7. GEAR CASE/ANODE/WATER SCREEN	4-27	3. CHARGE WIRE (Type with 6A charge coil)	16-17
8. EXTENSION CASE	4-28	4. NEUTRAL SWITCH/INDICATOR	16-20
9. EXHAUST CHAMBER COVER	4-31	5. IGNITION CONTROL MODULE	16-22
5. ENGINE COVERS	5-1	6. CONNECTOR BRACKET A	16-24
1. ENGINE COVER	5-1	7. IGNITION COIL	16-27
2. LEFT ENGINE UNDER COVER	5-2	8. REGULATOR/RECTIFIER	16-29
3. RIGHT ENGINE UNDER COVER	5-3	17. WIRING DIAGRAMS	17-1
6. FUEL SYSTEM	6-1		
1. SILENCER/CARBURETOR	6-2		
2. CHOKE CABLE	6-17		
3. FUEL PUMP/FUEL FILTER	6-18		
4. FUEL TANK	6-21		
7. RECOIL STARTER	7-1		
1. NEUTRAL START CABLE	7-1		
2. RECOIL STARTER	7-2		
3. STARTER CASE B	7-10		
8. ENGINE REMOVAL/INSTALLATION	8-1		
1. ENGINE REMOVAL	8-1		
2. ENGINE INSTALLATION	8-6		
9. FLYWHEEL/TIMING BELT	9-1		
1. FLYWHEEL/COILS	9-2		
2. TIMING BELT/PULLEYS	9-8		

1. SPECIFICATIONS	2. DIMENSIONAL DRAWINGS
-------------------	-------------------------

1. SPECIFICATIONS

DIMENSIONS AND WEIGHTS

BF15D

Model	BF15D					
Description Code	BALJ					
Type	SH	SHS	SR	LH	LHS	LR
Overall length	650 mm (25.6 in)		640 mm (25.2 in)	650 mm (25.6 in)		640 mm (25.2 in)
Overall width	350 mm (13.8 in)					
Overall height	1,110 mm (43.7 in)			1,240 mm (48.8 in)		
Dry weight (With propeller mounted)	46.5 kg (103 lb)	50.0 kg (110 lb)	50.5 kg (111 lb)	49.5 kg (109 lb)	53.0 kg (117 lb)	52.0 kg (115 lb)
Operating weight	47.9 kg (106 lb)	51.4 kg (113 lb)	51.9 kg (114 lb)	50.9 kg (112 lb)	54.4 kg (120 lb)	53.4 kg (118 lb)
Transom height	433 mm (17.0 in)			563 mm (22.2 in)		
Transom angle	5 stage adjustment (4° , 8° , 12° , 16° , 20°)					
Tilting angle	71°		72°			
Swivel angle	45° right and left					

BF20D

Model	BF20D					
Description Code	BAMJ					
Type	SH	SHS	SR	LH	LHS	LR
Overall length	650 mm (25.6 in)		640 mm (25.2 in)	650 mm (25.6 in)		640 mm (25.2 in)
Overall width	350 mm (13.8 in)					
Overall height	1,110 mm (43.7 in)			1,240 mm (48.8 in)		
Dry weight	46.5 kg (103 lb)	50.0 kg (110 lb)	50.5 kg (111 lb)	49.5 kg (109 lb)	53.0 kg (117 lb)	52.0 kg (115 lb)
Operating weight	47.9 kg (106 lb)	51.4 kg (113 lb)	51.9 kg (114 lb)	50.9 kg (112 lb)	54.4 kg (120 lb)	53.4 kg (118 lb)
Transom height	433 mm (17.0 in)			563 mm (22.2 in)		
Transom angle	5 stage adjustment (4° , 8° , 12° , 16° , 20°)					
Tilting angle	71°		72°			
Swivel angle	45° right and left					

ENGINE

Model	BF15D	BF20D
Type	Water cooled 4-stroke, overhead valve, vertical twin	
Displacement	350 cm ³ (21.5 cu. in)	
Bore x stroke	59 x 64 mm (2.3 x 2.5 in)	
Rated horsepower	11.0 kW (15 PS) at 5,000 min ⁻¹ (rpm)	14.7 kW (20 PS) at 5,500 min ⁻¹ (rpm)
Maximum torque	25.2 N·m (2.6 kgf·m, 18.8 lbf·ft) at 3,500 min ⁻¹ (rpm)	25.8 N·m (2.6 kgf·m, 18.8 lbf·ft) at 5,000 min ⁻¹ (rpm)
Compression ratio	9.2: 1	
Fuel consumption	313 g (11.0 oz.)/kWh	337 g (11.9 oz.)/kWh
Cooling system	Forced water circulation by impeller pump with thermostat	
Ignition system	CDI	
Ignition timing	0° ± 2° B.T.D.C.	
Spark plug	CR5EH-9 (NGK), U16FER9 (DENSO)	
Carburetor	Horizontal butterfly valve type single carburetor	
Lubricating system	Forced lubrication by trochoid pump	
Oil capacity	1.0 ℓ (1.06 US qt, 0.88 Imp qt) at oil change 1.3 ℓ (1.37 US qt, 1.14 Imp qt) with oil filter replacement	
Recommended oil	SAE 10W-30, API Service classification SG/SH/SJ	
Starting system	SH, LH Type: Recoil starter SHS, SR, LHS, LR Type: Electric starter and recoil starter	
Stopping system	Ignition primary circuit ground	
Fuel used	Automotive unleaded gasoline (minimum 86 pump octane)	
Fuel tank capacity	Steel tank: 13 ℓ (3.43 US gal, 2.86 Imp gal) Plastic tank: 12 ℓ (3.17 US gal, 2.64 Imp gal)	
Fuel pump	Mechanical plunger type	
Exhaust system	Under water type	

LOWER UNIT

Model	BF15D, BF20D	
Clutch	Dog clutch (Forward-neutral-reverse)	
Gear ratio	0.48 (13/27)	
Reduction type	Spiral bevel gear	
Gear case oil capacity	0.285 ℓ (0.27 US qt, 0.23 Imp qt)	
Propeller	Number of blades	4
	Diameter	235 mm (9-1/4 in)
	Pitch	203 mm (8.0 in)
	Rotating direction	Clockwise (viewed from rear)

BF15D·BF20D

Types of Honda BF15D/BF20D Outboard Motors

It may be necessary to refer to this chart for reference purposes when reading this manual.

Model	Type	Shaft length	Tiller handle	Remote control	Electric starter	Recoil starter	Charge coil	Starting enrichment system
BF15D/ BF20D	SH	S	●			●	6A	Manual
	SHS	S	●		●	●	12A	Automatic
	SR	S		●	●	●	12A	Automatic
	LH	L	●			●	6A	Manual
	LHS	L	●			●	12A	Automatic
	LR	L			●	●	12A	Automatic

S: Short shaft L: Long shaft

2. DEMENSIONAL DRAWINGS

• Tiller Handle Type

[1] Type	H	T	θ
S	1,110 (43.7)	433 (17.0)	71°
L	1,240 (48.8)	563 (22.2)	72°

Unit: mm (in)

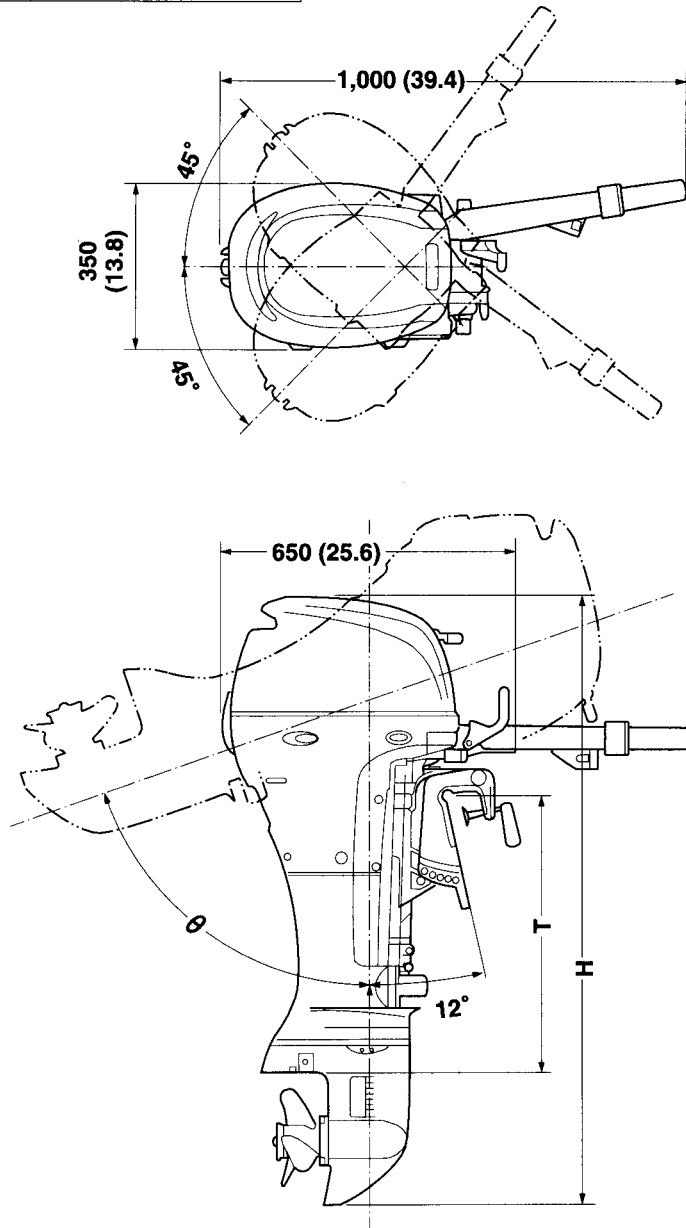

• Remote Control Type

[1] Type	H	T
S	1,110 (43.7)	433 (17.0)
L	1,240 (48.8)	563 (22.2)

Unit: mm (in)

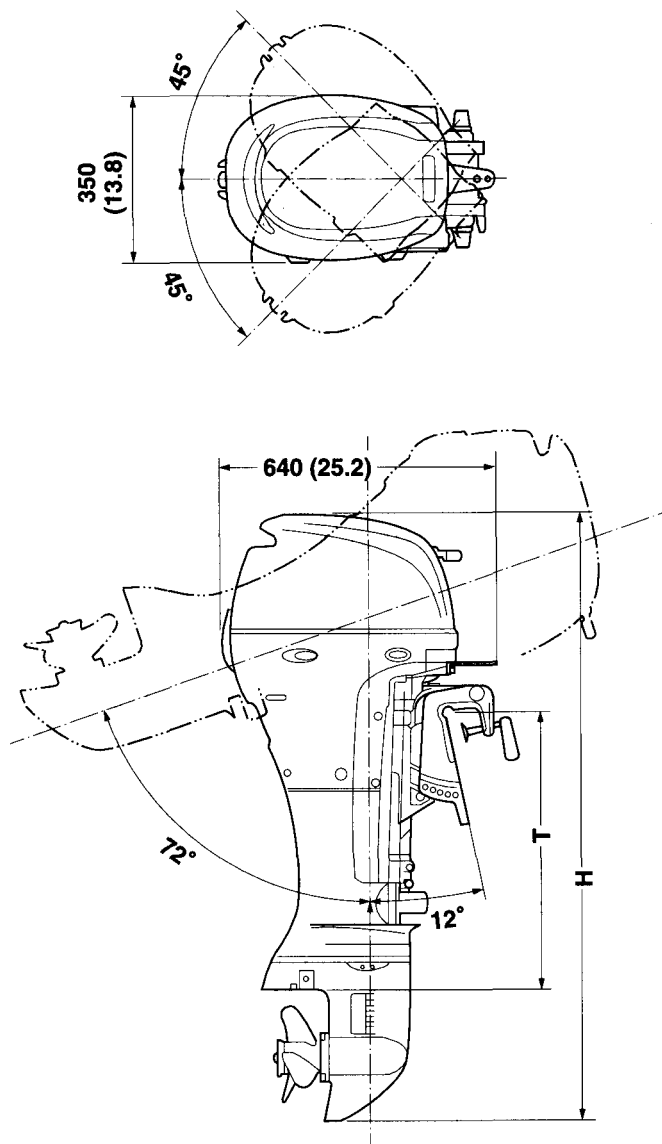

• Propeller Shaft Detail

Unit: mm (in)

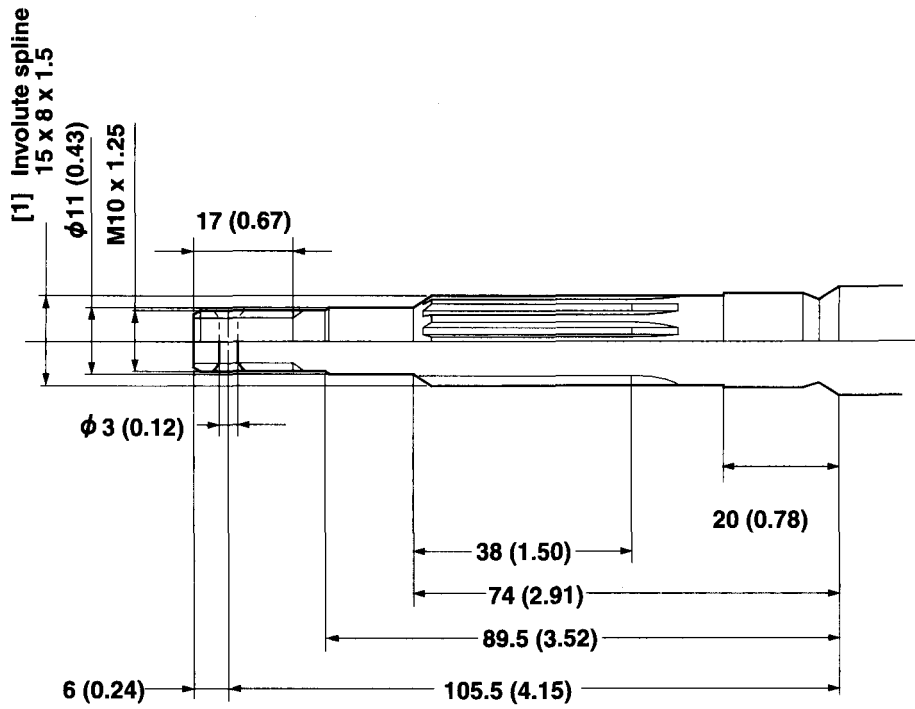

- | | |
|---------------------------------------|----------------------------|
| 1. THE IMPORTANCE OF PROPER SERVICING | 6. TORQUE VALUES |
| 2. IMPORTANT SAFETY PRECAUTIONS | 7. SPECIAL TOOLS |
| 3. SYMBOLS USED IN THIS MANUAL | 8. TROUBLESHOOTING |
| 4. SERIAL NUMBER LOCATIONS | 9. CABLE & HARNESS ROUTING |
| 5. MAINTENANCE STANDARDS | 10. LUBRICATION POINTS |

1. THE IMPORTANCE OF PROPER SERVICING

Proper servicing is essential to the safety of the operator and the reliability of the engine. Any error or oversight made by the technician while servicing can easily result in faulty operation, damage to the engine or injury to the operator.

⚠ CAUTION

Improper servicing can cause an unsafe condition that can lead to serious injury or death.

Follow the procedures and precautions in this shop manual carefully.

Some of the most important precautions are given below. However, we cannot warn you of every conceivable hazard that can arise in performing maintenance or repairs. Only you can decide whether or not you should perform a given task.

⚠ WARNING

Failure to follow maintenance instructions and precautions can cause you to be seriously hurt or killed.

Follow the procedures and precautions in this shop manual carefully.

2. IMPORTANT SAFETY PRECAUTIONS

Make sure you have a clear understanding of all basic shop safety practices and that you are wearing appropriate clothing and using safety equipment. When performing any service task, be especially careful of the following:

- Read all of the instructions before you begin, and make sure you have the tools, the replacement or repair parts, and the skills required to perform the tasks safely and completely.
- Protect your eyes by using proper safety glasses, goggles, or face shields any time you hammer, drill, grind, or work around pressurized air or liquids, and springs or other stored-energy components. If there is any doubt, put on eye protection.
- Use other protective wear when necessary, for example gloves or safety shoes. Handling hot or sharp parts can cause severe burns or cuts. Before you grab something that looks like it can hurt you, stop and put on gloves.
- Protect yourself and others whenever you have engine-powered equipment up in the air. Any time you lift an outboard motor with a hoist, make sure that the hoist hook is securely attached to the outboard motor.

Make sure the engine is off before you begin any servicing procedures, unless the instruction tells you to do otherwise. This will help eliminate several potential hazards:

- Carbon monoxide poisoning from engine exhaust. Be sure there is adequate ventilation whenever you run the engine.
- Burns from hot parts. Let the engine and exhaust system cool before working in those areas.
- Injury from moving parts. If the instruction tells you to run the engine, be sure your hands, fingers, and clothing are out of the way.

Gasoline vapors and hydrogen gasses from batteries are explosive. To reduce the possibility of a fire or explosion, be careful when working around gasoline or battery.

- Use only a nonflammable solvent, not gasoline, to clean parts.
- Never drain or store gasoline in an open container.
- Keep all cigarettes, sparks, and flames away from all fuel-related parts.

3. SYMBOLS USED IN THIS MANUAL

As you read this manual, you may find the following symbols with the instructions.



: A special tool is required to perform the procedure.



: Apply grease.



: Apply oil.



: Indicates the diameter, length, and quantity of metric flange bolt used.



: Indicates the reference page.

4. SERIAL NUMBER LOCATIONS

The engine serial number is located on the cylinder block and the frame serial number is located on the stern bracket. Always refer to these numbers when making technical inquiries or ordering parts in order to obtain the correct parts for the outboard motor being serviced.

FRAME SERIAL NUMBER

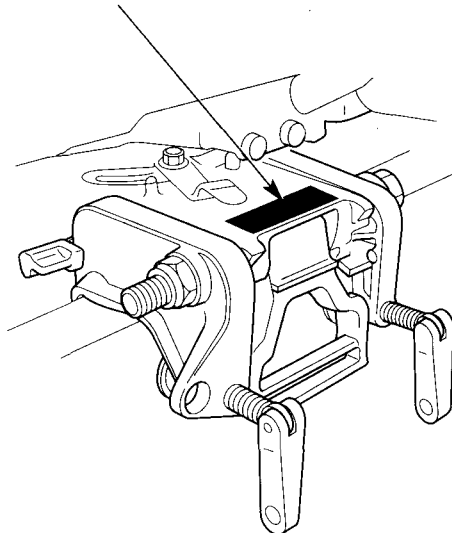

ENGINE SERIAL NUMBER

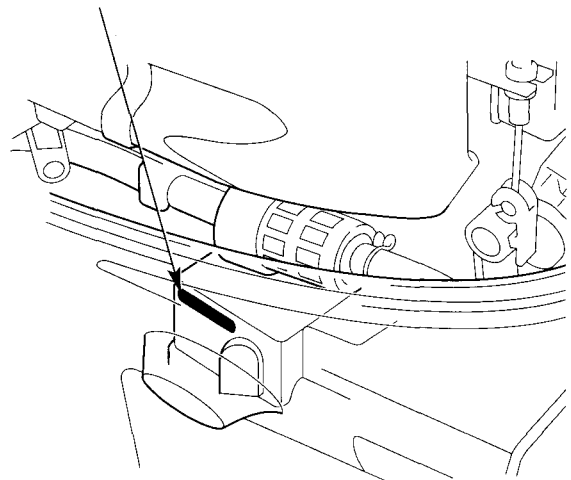

5. MAINTENANCE STANDARDS

• ENGINE

Part	Item	Standard	Service limit	
Engine	Idle speed (in neutral)	900 ± 50 min ⁻¹ (rpm)	—	
	Recommended full throttle rpm	BF15D	4,500 – 5,500 min ⁻¹ (rpm)	—
		BF20D	5,000 – 6,000 min ⁻¹ (rpm)	—
	Cylinder compression	1,370 ± 98 kPa (14.0 ± 1.0 kgf/cm ² , 199 ± 14 psi) at 600 min ⁻¹ (rpm)	—	
Cylinder heads	Warpage	0.05 mm (0.002 in) max.	0.08 mm (0.003 in)	
	Valve seat width	IN/EX 0.9 – 1.1 mm (0.035 – 0.043 in)	2.0 mm (0.08 in)	
	Camshaft journal I.D.	No. 1 20.000 – 20.021 mm (0.7874 – 0.7882 in)	20.05 mm (0.789 in)	
Valves	Clearance	IN	0.15 – 0.19 mm (0.006 – 0.007 in)	—
		EX	0.21 – 0.25 mm (0.008 – 0.010 in)	—
	Stem O.D.	IN	4.975 – 4.990 mm (0.1959 – 0.1965 in)	4.95 mm (0.195 in)
		EX	4.955 – 4.970 mm (0.1951 – 0.1957 in)	4.93 mm (0.194 in)
Valve guides	Guide I.D.	IN/EX 5.000 – 5.012 mm (0.1969 – 0.1973 in)	5.04 mm (0.198 in)	
	Stem-to-guide clearance	IN	0.010 – 0.037 mm (0.0004 – 0.0015 in)	0.07 mm (0.003 in)
		EX	0.030 – 0.067 mm (0.0012 – 0.0026 in)	0.12 mm (0.005 in)
Valve springs	Free length	33.28 mm (1.310 in)	32.0 mm (1.26 in)	
Rocker arms, rocker arm shaft	Shaft O.D.	12.962 – 12.980 mm (0.5103 – 0.5110 in)	12.92 mm (0.509 in)	
	Arm I.D.	13.000 – 13.018 mm (0.5118 – 0.5125 in)	13.04 mm (0.513 in)	
	Shaft-to-rocker arm clearance	0.020 – 0.056 mm (0.0008 – 0.0022 in)	0.07 mm (0.003 in)	
Camshaft	Camshaft axial play	0.05 – 0.30 mm (0.002 – 0.012 in)	0.4 mm (0.016 in)	
	Cam height (IN/EX)	BF15D	23.725 – 23.885 mm (0.9341 – 0.94041 in)	23.103 mm (0.9010 in)
		BF20D	24.976 – 25.136 mm (0.9833 – 0.9896 in)	24.493 mm (0.9643 in)
	Journal O.D.	No. 1	19.959 – 19.980 mm (0.7858 – 0.7866 in)	19.93 mm (0.785 in)
		Oil pump	15.966 – 15.984 mm (0.6286 – 0.6293 in)	15.94 mm (0.628 in)
Journal-to-shaft clearance	No. 1	0.020 – 0.062 mm (0.0008 – 0.0024 in)	0.08 mm (0.003 in)	
Oil pump	Rotor tip clearance	0.15 mm (0.006 in) max.	0.20 mm (0.008 in)	
	Outer rotor-to-body clearance	0.15 – 0.21 mm (0.006 – 0.008 in)	0.26 mm (0.010 in)	
	Rotor-to-pump body side clearance	0.04 – 0.09 mm (0.002 – 0.004 in)	0.12 mm (0.005 in)	
	Pump body I.D.	40.71 – 40.74 mm (1.603 – 1.604 in)	40.76 mm (1.605 in)	
	Pump body depth	12.04 – 12.07 mm (0.474 – 0.475 in)	12.11 mm (0.477 in)	
	Outer rotor height	11.98 – 12.00 mm (0.4717 – 0.4724 in)	11.96 mm (0.471 in)	
	Camshaft journal I.D.	16.000 – 16.018 mm (0.6299 – 0.6306 in)	16.05 mm (0.632 in)	
	Pump body-to-camshaft clearance	0.016 – 0.052 mm (0.0006 – 0.0020 in)	0.07 mm (0.003 in)	
	Pump body O.D.	30.950 – 30.975 mm (1.2186 – 1.2195 in)	—	
Fuel pump	Pump arm I.D.	13.000 – 13.080 mm (0.5118 – 0.5150 in)	13.10 mm (0.516 in)	
	Shaft-to-pump arm clearance	0.020 – 0.118 mm (0.0008 – 0.0046 in)	0.13 mm (0.005 in)	
Cylinders	Sleeve I.D.	59.000 – 59.015 mm (2.3228 – 2.3234 in)	59.055 mm (2.3250 in)	
	Warpage	0.07 mm (0.003 in) max.	0.10 mm (0.004 in)	

BF15D-BF20D

ENGINE (continued)

Part	Item		Standard	Service limit
Pistons	Skirt O.D.		58.970 – 58.990 mm (2.3216 – 2.3224 in)	58.92 mm (2.320 in)
	Piston-to-cylinder clearance		0.010 – 0.045 mm (0.0004 – 0.0015 in)	0.10 mm (0.004 in)
	Piston pin bore I.D.		16.002 – 16.008 mm (0.6300 – 0.6302 in)	16.02 mm (0.638 in)
Piston pins	Piston pin O.D.		15.994 – 16.000 mm (0.6297 - 0.6299 in)	15.97 mm (0.629 in)
	Piston-to-piston pin clearance		0.002 – 0.014 mm (0.0001 – 0.0006 in)	0.04 mm (0.002 in)
Piston rings	Side clearance	Top/second	0.025 – 0.055 mm (0.0010 – 0.0022 in)	0.10 mm (0.004 in)
		Oil	0.055 – 0.140 mm (0.0022 – 0.0055 in)	0.20 mm (0.008 in)
	End gap	Top	0.15 – 0.30 mm (0.006 – 0.012 in)	0.50 mm (0.020 in)
		Second	0.35 – 0.50 mm (0.014 – 0.020 in)	0.70 mm (0.028 in)
		Oil	0.20 – 0.80 mm (0.008 – 0.031 in)	1.0 mm (0.04 in)
	Thickness	Top/second	1.175 – 1.190 mm (0.0463 – 0.0469 in)	1.08 mm (0.043 in)
Oil (side rail)		2.380 – 2.450 mm (0.0937 – 0.0965 in)	2.28 mm (0.090 in)	
Connecting rods	Small end I.D.		16.007 – 16.022 mm (0.6302 – 0.6308 in)	16.05 mm (0.632 in)
	Big end I.D.		32.020 – 32.033 mm (1.2606 – 1.2611 in)	32.06 mm (1.262 in)
	Big end oil clearance		0.020 – 0.044 mm (0.0008 – 0.0017 in)	0.06 mm (0.002 in)
	Big end side clearance		0.1 – 0.4 mm (0.004 - 0.016 in)	0.5 mm (0.02 in)
Crankshaft	Main journal O.D.		35.979 – 35.990 mm (1.4165 – 1.4169 in)	35.96 mm (1.416 in)
	Crank pin O.D.		31.989 – 32.000 mm (1.2594 – 1.2598 in)	31.96 mm (1.258 in)
	Main journal oil clearance		0.018 – 0.042 mm (0.0007 - 0.0017 in)	0.06 mm (0.002 in)
	Side clearance		0.1 – 0.4 mm (0.004 – 0.016 in)	0.55 mm (0.022 in)
Carburetor	Main jet	BF15D	Except Bodensee type: #102 Bodensee type: #102	—
		BF20D	Except Bodensee type: #125 Bodensee type: #115	—
	Pilot screw opening		See pages 6-9 and 10.	—
	Float height		13.7 mm (0.54 in)	—

• ELECTRICAL

Part	Item		Standard	Service limit
Spark plug	Gap		0.8 – 0.9 mm (0.031 – 0.035 in)	—
Ignition coil	Primary coil resistance		0.8 – 1.0 Ω	—
	Secondary coil resistance (with plug caps)		23.0 – 34.8 kΩ	—
Starter Motor	Brush length		10 mm (0.4 in)	6 mm (0.23 in)
	Mica depth		—	0.2 mm (0.01 in)
Charge coil	Resistance	12A charge coil	0.2 – 0.3 Ω	—
		6A charge coil	0.23 – 0.29 Ω	—
Exciter coil	Resistance	Electric starter type	5.0 – 7.4 Ω	—
		Recoil starter type	6.1 – 7.5 Ω	—
Pulse generator	Resistance		351 – 429 Ω	—
SE thermal valve heater coil	Resistance		1.2 – 1.8 Ω	—

• LOWER UNIT

Part	Item		Standard	Service limit
Propeller shaft	Shaft O.D.	Forward gear area	16.973 – 16.984 mm (0.6682 – 0.6687 in)	16.95 mm (0.667 in)
Forward gear	I.D.		17.000 – 17.018 mm (0.6693 – 0.6700 in)	17.04 mm (0.671 in)
Vertical shaft	Shaft O.D.		14.989 – 15.000 mm (0.5901 – 0.5906 in)	14.97 mm (0.589 in)

6. TORQUE VALUES

• Engine

Item	Thread dia. x pitch	Torque		
		N•m	kgf•m	lbf•ft
Crankcase cover bolts	M6 x 1.0	14	1.4	10
Oil pressure switch	PT1/8 (Apply sealant to the threads)	8	0.8	6
Oil drain bolt	M8 x 1.25	6	0.6	4
Oil filter cartridge	M20 x 1.5	12	1.2	9
Spark plugs	M10 x 1.0	12	1.2	9
Cylinder head bolts (L=83 mm)	M8 x 1.25 (Apply oil to threads)	26	2.7	20
Cylinder head bolts (L=40 mm)	M8 x 1.25	24	2.4	17
Valve adjusting lock nuts	M5 x 0.5	8	0.8	5.8
Connecting rod bolts	M6 x 1.0	12	1.2	9
Timing belt driven pulley bolt	M6 x 1.0	16	1.6	12
Recoil starter pulley bolts	M6 x 1.0	11	1.1	8
Flywheel nut	M16 x 1.5 (Apply oil to the thread)	132	13.5	98
Timing belt drive pulley lock nut	M30 x 1.0 (Apply oil to the thread)	69	7.0	51
Oil pump cover bolts	M5 x 0.8	5	0.5	3.6
Oil pump bolts	M6 x 1.0	11	1.1	8
Silencer bolts	M6 x 1.0	9	0.9	6.5
Silencer cover bolt	M6 x 1.0	10	1.0	7
Oil case bolts	M8 x 1.25	24	2.4	17
Thermo sensor	M12 x 1.5	18	1.8	13
Exhaust chamber cover bolts	M6 x 1.0	11	1.1	8

• Gear Case

Item	Thread dia. x pitch	Torque		
		N•m	kgf•m	lbf•ft
Gear case bolts	M6 x 1.0	12	1.2	9
Propeller 10 mm crown head nut	M10 x 1.25	See page 4-2		
Propeller shaft holder bolts	M6 x 1.0	12	1.2	9
Oil level bolt	M8 x 1.25	3.5	0.36	2.6
Oil drain bolt	M8 x 1.25	3.5	0.36	2.6
Water pump housing bolts	M6 x 1.0	12	1.2	9
Impeller housing bolts	M6 x 1.0	11	1.1	8
Water screen nuts	M5 x 0.8	1	0.1	0.7
Anode metal nut	M6 x 1.0	10	1.0	7
Shift rod B lock nut	M6 x 1.0	10	1.0	7

BF15D·BF20D

• Cover

Item	Thread dia. x pitch	Torque		
		N·m	kgf·m	lbf·ft
Left engine under cover screw	M5 x 0.8	4.5	0.46	3.3
Right engine under cover screw	M5 x 0.8	4.5	0.46	3.3

• Extension Case/Mount Rubber

Item	Thread dia. x pitch	Torque		
		N·m	kgf·m	lbf·ft
Extension case bolts	M8 x 1.25	24	2.4	17
Upper mount rubber stay bolt	M6 x 1.0	12	1.2	9
Lower mount rubber bolts	M8 x 1.25	22	2.2	16
Lower mount rubber cover bolts	M6 x 1.0	12	1.2	9
Upper mount rubber bolt	M10 x 1.25	38	3.9	28
Steering friction lever lock nut	M8 x 0.75	2.5	0.25	1.8

• Stern Bracket

Item	Thread dia. x pitch	Torque		
		N·m	kgf·m	lbf·ft
Tilting bolt lock nut (Tiller handle S type)	M8 x 1.25	24	2.4	17
Tilting shaft nut (Except tiller handle S type)	7/8-14UNF	17	1.7	13
Stern bracket nut (Except tiller handle S type)	M8 x 1.25	21	2.1	15

• Tiller Handle

Item	Thread dia. x pitch	Torque		
		N·m	kgf·m	lbf·ft
Tiller handle bracket bolts	M10 x 1.25	33	3.4	25
Tiller handle pivot nut	M8 x 1.25	8	0.8	6
Throttle cable set plate screws	4 mm screw	1.5	0.15	1.1
Shift lever pivot bolt	M6 x 1.0	12	1.2	9
Emergency stop switch nut	M16 x 1.0	1.5	0.15	1.1
Reverse lock bolt	M6 x 1.0	12	1.2	9
Throttle cable lock nut	M6 x 1.0	4.5	0.45	3.3
Starter switch nut	M16 x 1.0	1.5	0.15	1.1

• Frame/Electrical Equipment

Item	Thread dia. x pitch	Torque		
		N•m	kgf•m	lbf•ft
Shift rod B lock nut	M6 x 1.0	10	1.0	7
Fuel connector B bolt	M6 x 1.0	12	1.2	9
Choke cable nut	M11 x 1.25	2.5	0.25	1.8
SE valve nut	M12 x 1.0	2	0.2	1.4
Neutral switch nut	M20 x 1.0	2.5	0.25	1.8
Neutral start cable nut	M6 x 1.0	3.5	0.36	2.6
Starter magnetic switch bolts	M6 x 1.0	7	0.7	5
Starter cord terminal nut	M6 x 1.0	6.5	0.65	4.7
Starter cord self-locking nut	M6 x 1.0	5.5	0.55	4.0
Starter cable terminal nut	M6 x 1.0	5.5	0.55	4.0

• Use standard torque values of fastener that are not listed in this table below.

STANDARD TORQUE

Item	Thread dia. x pitch	Torque		
		N•m	kgf•m	lbf•ft
Screw	4 mm	2	0.2	1.4
	5 mm	4.2	0.43	3.1
	6 mm	9	0.9	6.5
Hex. bolt and nut	5 mm	5.2	0.53	3.8
	6 mm	10	1.0	7
	8 mm	21.5	2.19	15.8
	10 mm	34	3.5	26
	12 mm	54	5.5	40
Flange bolt and nut	6 mm	12	1.2	9
	8 mm	26.5	2.7	20
	10 mm	39	4.0	29
	12 mm	59	6.0	43
SH (small head flange) bolt	6 mm	10	1.0	7
CT (self tapping) bolt	5 mm	5.5	0.56	4.0
	6 mm	12	1.2	9

7. SPECIAL TOOLS

No.	Tool name	Tool number	Application
1	Float level gauge	07401-0010000	Carburetor float level inspection
2	Oil pressure gauge attachment	07406-0030000	Oil pressure inspection
3	Oil pressure gauge set	07506-3000000	Oil pressure inspection
4	Remover weight	07741-0010201	Bearing or bearing outer race removal
5	Attachment, 32 x 35 mm	07746-0010100	Needle bearing installation
	Attachment, 42 x 47 mm	07746-0010300	6005 ball bearing installation Taper roller bearing outer race installation
	Attachment, 24 x 26 mm	07746-0010700	Propeller shaft water seal installation
	Attachment, 22 x 24 mm	07746-0010800	Propeller shaft needle bearing removal Water pump water seal installation
6	Pilot, 15 mm	07746-0040300	Water pump needle bearing installation Water pump water seal installation
	Pilot, 17 mm	07746-0040400	Needle bearing installation Propeller shaft water seal installation
	Pilot, 25 mm	07746-0040600	6005 ball bearing installation Taper roller bearing outer race installation
7	Driver	07749-0010000	Bearing, oil seal or water seal installation (driver for No. 5 and 6)
8	Valve spring compressor	07757-0010000	Valve cotter removal/installation
9	Valve seat cutter, 45° 27.5 mm	07780-0010200	Intake valve seat reconditioning
	Valve seat cutter, 45° 22 mm	07780-0010701	Exhaust valve seat reconditioning
10	Valve seat cutter, 32° 25 mm	07780-0012000	Exhaust valve seat reconditioning
	Valve seat cutter, 32° 30 mm	07780-0012200	Intake valve seat reconditioning
11	Valve seat cutter, 60° 22 mm	07780-0014202	Exhaust valve seat reconditioning
	Valve seat cutter, 60° 26 mm	07780-0014500	Intake valve seat reconditioning
12	Cutter holder 5.0 mm	07781-0010400	Valve seat reconditioning

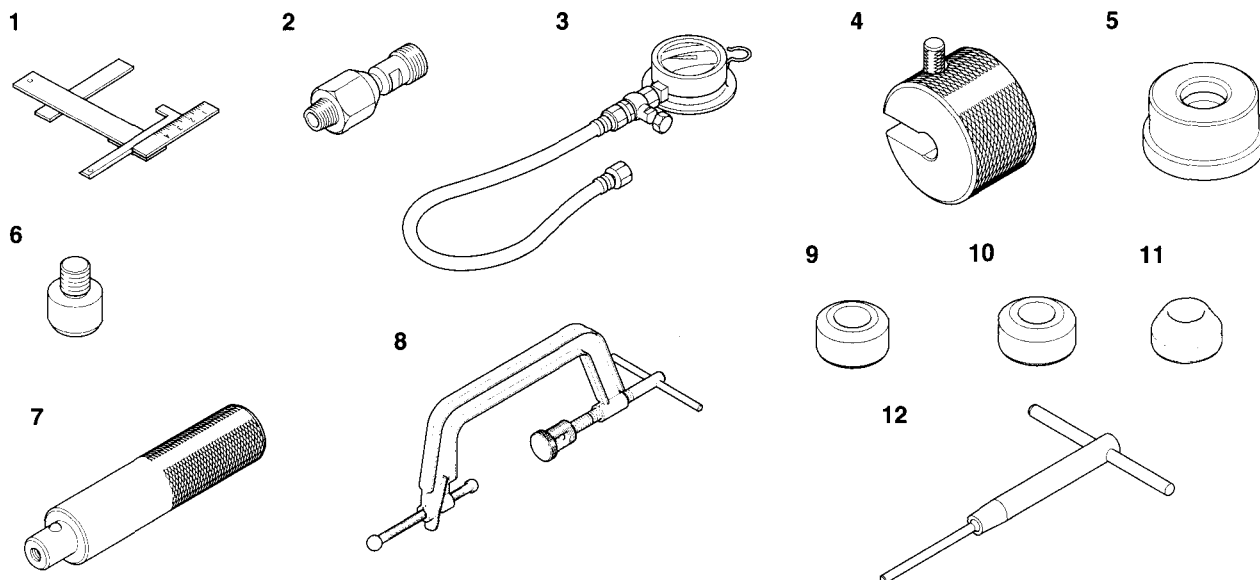

No.	Tool name	Tool number	Application
13	Valve adjusting wrench 3 mm	07908-KE90200	Valve clearance adjustment
14	Crankshaft holder, 26 mm	07923-ZA00100	Crankshaft holding
15	Bearing remover handle	07936-3710100	Taper roller bearing outer race removal
16	Bearing remover, 15 mm	07936-KC10500	Needle bearing removal
17	Bearing remover, 25 mm	07936-ZV10100	Bearing removal
18	Driver handle, 325 mm	07946-MJ00100	Needle bearing removal/installation
	Driver handle, 280 mm	07949-3710001	Needle bearing removal/installation
	Driver handle, 370 mm	07VMF-KZ30200	Needle bearing removal
19	Valve guide reamer, 5.0 mm	07984-MA60001	Valve guide reaming
20	Oil filter wrench	07HAA-PJ70100	Oil filter removal
21	Bearing race puller	07LPC-ZV30100	Taper roller bearing outer race removal
22	Puller jaw, 25 mm	07WPC-ZW50100	Taper roller bearing outer race removal
23	Driver 14.5 x 18.5 mm	07ZPF-ZW90300	Needle bearing installation
24	Installer shaft	07VMF-KZ30200	Needle bearing removal
25	Bearing installer	070PD-ZY10100	Needle bearing removal

13

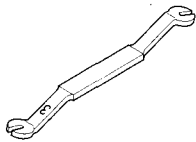

14



15

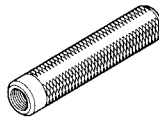

16

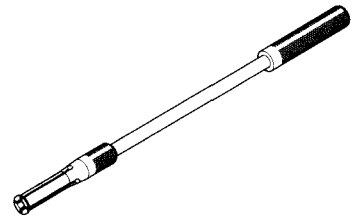

17

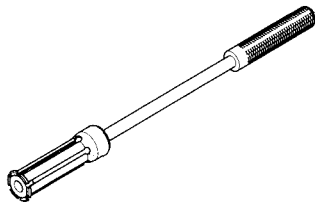

18

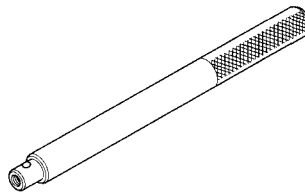

19

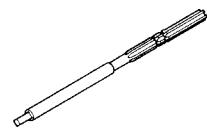

20

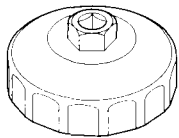

21

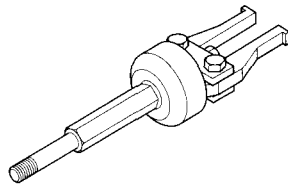

22

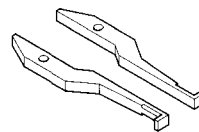

23

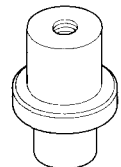

24

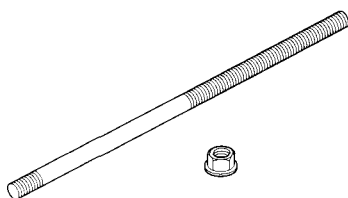

25



8. TROUBLESHOOTING

a. ENGINE

• Hard Starting

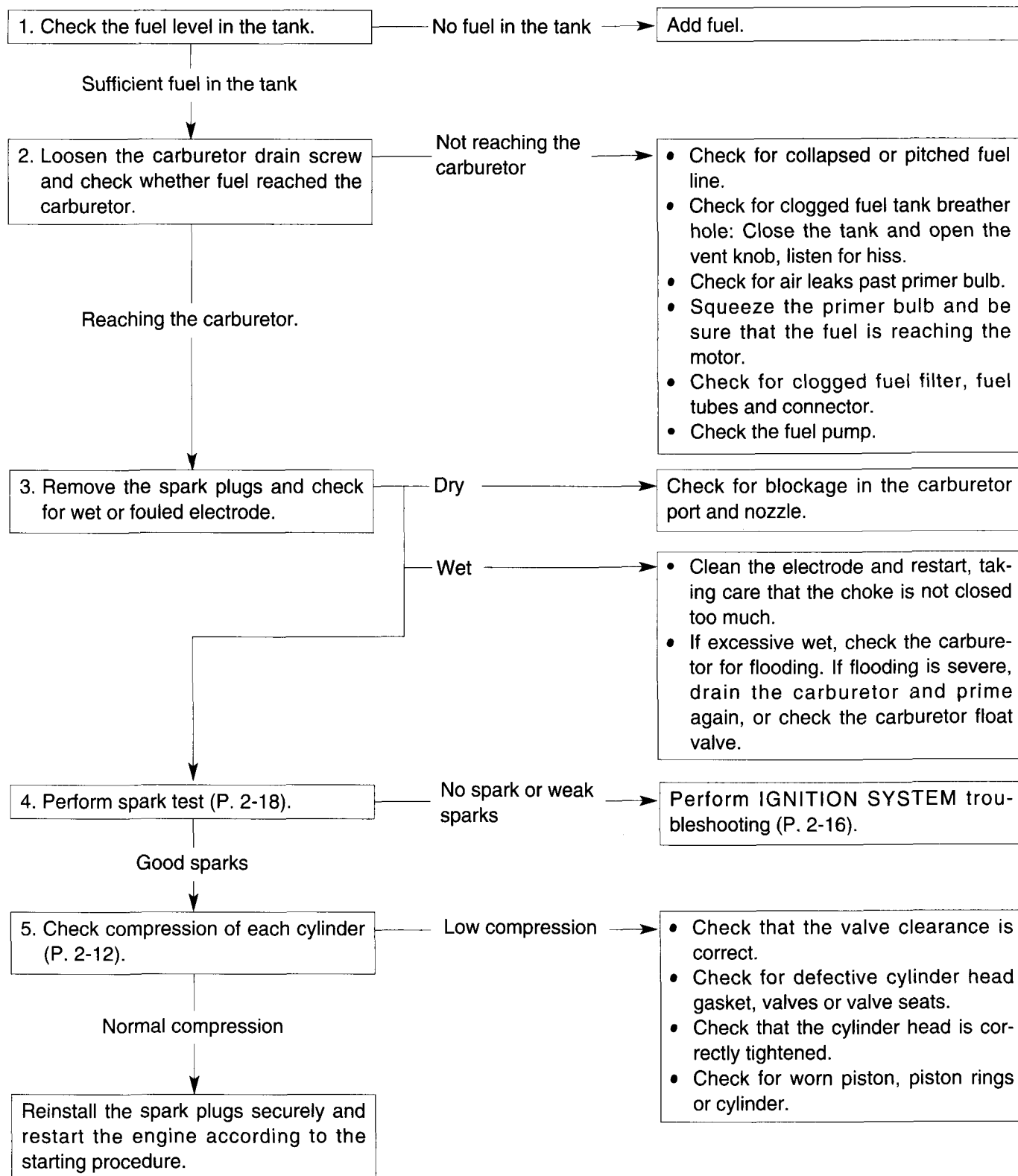

• CYLINDER COMPRESSION CHECK

- 1) Shift the gear into the neutral position.
- 2) Disengage the emergency stop switch clip from the emergency stop switch.
- 3) Remove the engine cover and the both spark plugs.
- 4) Install a compression gauge in the No. 1 cylinder plug hole.
- 5) Disconnect the remote control throttle cable from the throttle arm (remote control type only).
- 6) Manually hold the throttle arm or throttle lever in the full open position
- 7) Electric starter type: Turn the starter motor using the starter switch (tiller handle type) or ignition switch (remote control type) until stable compression is obtained.

Do not operate the starter motor for more than 5 seconds at one try. If stable compression is not obtained within 5 seconds, stop the starter motor and wait 10 - 20 seconds, and repeat the operation again.

Recoil starter type: Pull the recoil starter several times until stable compression is obtained

Cylinder compression	1,370±98 kPa (14.0±1.0 kgf/cm ² , 199±14 psi)
----------------------	---

- 8) Reinstall the compression gauge in the No. 2 cylinder plug hole and repeat steps 6 and 7.
- 9) After inspection, reinstall the removed parts in the reverse order of removal.

