

PREFACE

This manual covers the construction, function and servicing procedures of the Honda BF20A/BF25A outboard motors.

Careful observance of these instructions will result in better, safer service work.

Illustrations in this manual are based primarily on the BF25A LRS.

ALL INFORMATION, ILLUSTRATIONS, DIRECTIONS AND SPECIFICATIONS INCLUDED IN THIS PUBLICATION ARE BASED ON THE LATEST PRODUCT INFORMATION AVAILABLE AT THE TIME OF APPROVAL FOR PRINTING. HONDA MOTOR CO., LTD. RESERVES THE RIGHT TO MAKE CHANGES WITHOUT INCURRING ANY OBLIGATION WHATEVER. NO PART OF THIS PUBLICATION MAY BE REPRODUCED WITHOUT WRITTEN PERMISSION.

HONDA MOTOR CO., LTD.
SERVICE PUBLICATIONS OFFICE

CONTENTS

SPECIFICATIONS	1
SERVICE INFORMATION	2
MAINTENANCE	3
ENGINE COVER/THROTTLE/CHOKE	4
FUEL SYSTEM	5
FLYWHEEL/TIMING BELT	6
RECOIL STARTER (TILLER HANDLE TYPE ONLY)	7
ENGINE REMOVAL/INSTALLATION	8
WATER JACKET COVER/THERMOSTAT/ THERMO SWITCH	9
CYLINDER HEAD/VALVES/OIL PUMP	10
CRANKCASE/CYLINDER BLOCK/ CRANKSHAFT/PISTON	11
PROPELLER/GEAR CASE/ EXTENSION CASE	12
OIL PAN/ENGINE UNDER CASE/ SWIVEL CASE	13
STEERING LINK ARM/REMOTE CONTROL BOX (REMOTE CONTROL TYPE ONLY)	14
THROTTLE CABLE RACKET/SHIFT LEVER/ TILLER HANDLE (TILLER HANDLE TYPE ONLY)	15
ELECTRICAL EQUIPMENT	16
OPERATION	17
WIRING DIAGRAM	18
BF30 SUPPLEMENT	

SHOP MANUAL NEWS

PAGE 1 OF 2

**HONDA
OUTBOARD MOTOR
BF20A · BF25A**

Power Equipment

News No.
P/P-035

Issue Date
September '94

SOME PARTS OF CHANGES

Applicable information	Publication No.
BF20A · BF25A	66ZV700

CHANGE LOCATIONS

P.12-21

8. BACKLASH ADJUSTMENT

• FORWARD GEAR

BEFORE MODIFICATION

- 3) Turn the vertical shaft right and left while pressing it down with approximately 5 kg (11.0 lb) of force and measure the backlash.

Standard	0.10 – 0.29 mm (0.004 – 0.011 in)
----------	-----------------------------------

- 4) If the backlash is too large, increase the forward gear shim thickness and recheck the backlash.
If the backlash is too small, decrease the forward gear shim thickness and recheck the backlash.

P.12-22

• REVERSE GEAR

- 3) Turn the vertical shaft right and left while pressing it down with approximately 5 kg (11.0 lb) of force and measure the backlash.

Standard	0.10 – 0.39 mm (0.004 – 0.015 in)
----------	-----------------------------------

- 4) If the backlash is too large, increase the reverse gear shim thickness and recheck the backlash.
If the backlash is too small, decrease the reverse gear shim thickness and recheck the backlash.

AFTER MODIFICATION

- 3) Turn the vertical shaft right and left while pressing it down with approximately 5 kg (11.0 lb) of force and measure the backlash.

$$\text{Backlash} = \text{Dial Gauges measures} \times \frac{17.43^{*1}}{23^{*2}}$$

*1 The pinion gear radius of pitch circle

*2 The special tools (07MGJ-0010100) lever-length

Standard	0.10 – 0.29 mm (0.004 – 0.011 in)
----------	-----------------------------------

- 4) If the backlash is too large, increase the forward gear shim thickness and recheck the backlash.
If the backlash is too small, decrease the forward gear shim thickness and recheck the backlash.

Service limit	0.30 mm (0.012 in)
---------------	--------------------

- 3) Turn the vertical shaft right and left while pressing it down with approximately 5 kg (11.0 lb) of force and measure the backlash.

$$\text{Backlash} = \text{Dial Gauges measures} \times \frac{17.43}{23}$$

Standard	0.10 – 0.39 mm (0.004 – 0.015 in)
----------	-----------------------------------

- 4) If the backlash is too large, increase the reverse gear shim thickness and recheck the backlash.
If the backlash is too small, decrease the reverse gear shim thickness and recheck the backlash.

Service limit	0.40 mm (0.016 in)
---------------	--------------------

HONDA OUTBOARD MOTOR BF20A · BF25A

SHOP MANUAL NEWS

Power Equipment

News No.
P/P-032

Issue Date
August '94

SOME PARTS OF CHANGES

Applicable information	Publication No.
BF20A · BF25A	66ZV700

CHANGE LOCATIONS

The part numbers of the pin driver, 4mm and the special tool illustrations have been corrected as follows.

- Pin driver , 4mm

BEFORE MODIFICATION

07944-9350200



AFTER MODIFICATION

07744-0010300
or 07944-SA00000

- Special tool illustrations

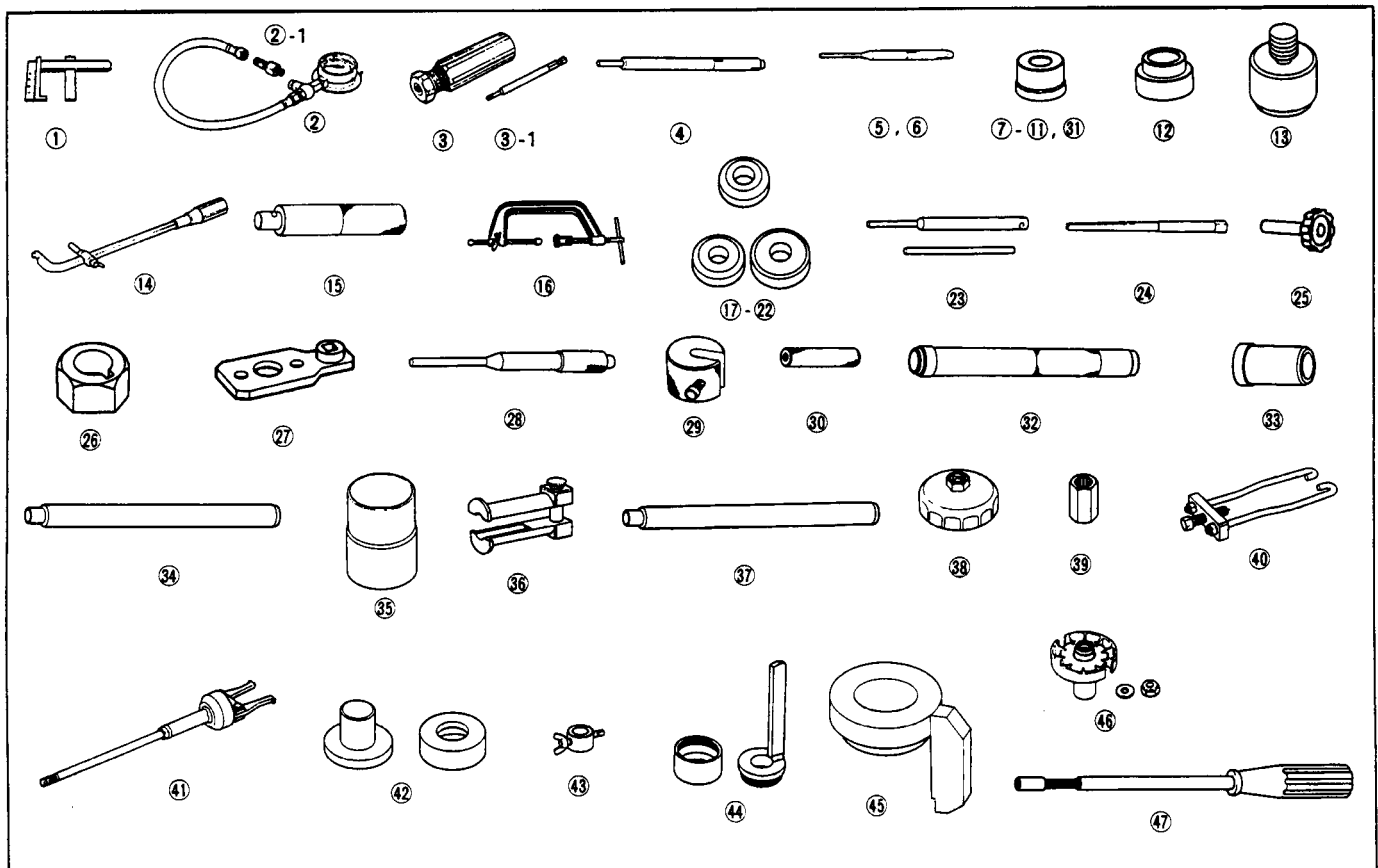

1. SPECIFICATIONS	2. DIMENSIONAL DRAWINGS
-------------------	-------------------------

1. SPECIFICATIONS

DIMENSIONS AND WEIGHTS

Item	Model	BF20A					
	Description code	BAHS	BAHL	BAHS	BAHL	BAHS	BAHL
Type	SH	LH	SHS	LHS	SRS	LRS	
Overall length	*1: 675 mm (26.6 in) *2: 1,005 mm (39.6 in)				640 mm (25.2 in)		
Overall width	380 mm (15.0 in)				375 mm (14.8 in)		
Overall height	1,190 mm (46.9 in)	1,315 mm (51.8 in)	1,190 mm (46.9 in)	1,315 mm (51.8 in)	1,190 mm (46.9 in)	1,315 mm (51.8 in)	
Dry weight	67 kg (147.7 lb)	69 kg (152.1 lb)	70 kg (154.3 lb)	72 kg (158.8 lb)	69 kg (152.1 lb)	71 kg (156.6 lb)	
Operating weight (incl. oil)	69 kg (152.1 lb)	71 kg (156.6 lb)	72 kg (158.8 lb)	74 kg (163.2 lb)	71 kg (156.6 lb)	73 kg (161.0 lb)	

*1: With Tiller Handle raised
*2: With Tiller Handle extended

DIMENSIONS AND WEIGHTS

Item	Model	BF25A					
	Description code	BAJS	BAJL	BAJS	BAJL	BAJS	BAJL
Type	SH	LH	SHS	LHS	SRS	LRS	
Overall length	*1: 675 mm (26.6 in) *2: 1,005 mm (39.6 in)				640 mm (25.2 in)		
Overall width	380 mm (15.0 in)				375 mm (14.8 in)		
Overall height	1,190 mm (46.9 in)	1,315 mm (51.8 in)	1,190 mm (46.9 in)	1,315 mm (51.8 in)	1,190 mm (46.9 in)	1,315 mm (51.8 in)	
Dry weight	67 kg (147.7 lb)	69 kg (152.1 lb)	70 kg (154.3 lb)	72 kg (158.8 lb)	69 kg (152.1 lb)	71 kg (156.6 lb)	
Operating weight (incl. oil)	69 kg (152.1 lb)	71 kg (156.6 lb)	72 kg (158.8 lb)	74 kg (163.2 lb)	71 kg (156.6 lb)	73 kg (161.0 lb)	

*1: With Tiller Handle raised
*2: With Tiller Handle extended

FRAME

Item	Model	BF20A/BF25A					
	Type	SH	LH	SHS	LHS	SRS	LRS
Transom height		431 mm (17.0 in)	552 mm (21.7 in)	431 mm (17.0 in)	552 mm (21.7 in)	431 mm (17.0 in)	552 mm (21.7 in)
Transom angle		5 stage adjustment (4°, 8°, 12°, 16°, 20°)					
Tilting angle		75°					
Swivel angle		40° right and left					

TYPES OF HONDA BF20A/BF25A OUTBOARD MOTORS

It may be necessary to refer to this chart for reference purposes when reading this manual.

Models	Types	Shaft Length		Tiller Handle	Remote Control	Electric Starter	Recoil Starter
		Short	Long				
BF20A/BF25A	SH	●		●			●
	LH		●	●			●
	SHS	●		●		●	●
	LHS		●	●		●	●
	SRS	●			●	●	●
	LRS			●		●	●

S: Short Shaft L: Long Shaft H: Tiller Handle R: Remote Control

ENGINE

Model	BF20A	BF25A
Type	4-stroke, O.H.C, 3-cylinder	
Displacement	499 cm ³ (30.5 cu in)	
Bore x stroke	58 x 63 mm (2.3 x 2.5 in)	
Rated power * 1	20 HP (14.9 kw)/4,500—5,500 min ⁻¹ (rpm)	25 HP (18.7 kw)/5,000—6,000 min ⁻¹ (rpm)
Maximum torque	3.55 kg-m (25.7 ft-lb)/3,000 min ⁻¹ (rpm)	3.59 kg-m (26.0 ft-lb)/4,000 min ⁻¹ (rpm)
Compression ratio	9.2 : 1	
Fuel consumption ratio	214 g/PSH (7.5 oz/PSH)	239 g/PSH (8.4 oz/PSH)
Cooling system	Forced water circulation by impeller pump with thermostat	
Ignition system	CDI	
Ignition timing	5—26° B.T.D.C.	
Spark plug	DR7EA (NGK), X22ESR-U (NIPPONDENSO)	
Carburetor	Horizontal type, butterfly valve (3 carburetor)	
Lubrication system	Pressure lubrication by trochoid pump	
Lubrication capacity	1.9ℓ (2.00 US qt, 1.67 Imp qt)	
Starter system	Electric starter or Recoil starter	
Stopping system	Grounding of primary circuit	
Fuel	Regular automotive gasoline (86 pump octane; unleaded preferred)	
Fuel tank capacity	25 ℓ (6.6 US gal, 5.5 Imp gal)	
Fuel pump	Mechanical plunger type	
Exhaust system	Under water type	
Recommended oil	SAE 10W-30	

*1: Full throttle range.

LOWER UNIT

Clutch	Dog clutch (Forward—Neutral—Reverse)
Gear ratio	0.48 (13/27)
Reduction	Spiral bevel
Gear case oil capacity	0.29 ℓ(0.307 US qt, 0.255 Imp qt)
Propeller No. of blades-Dia. x Pitch	3-235 x 305 mm (9-1/4 x 12.0 in)
Propeller rotating direction	Clockwise (viewed from rear)
Propeller driving system	Spline

2. DIMENSIONAL DRAWINGS

Unit: mm (in)

Remote control type
[]: Short shaft type

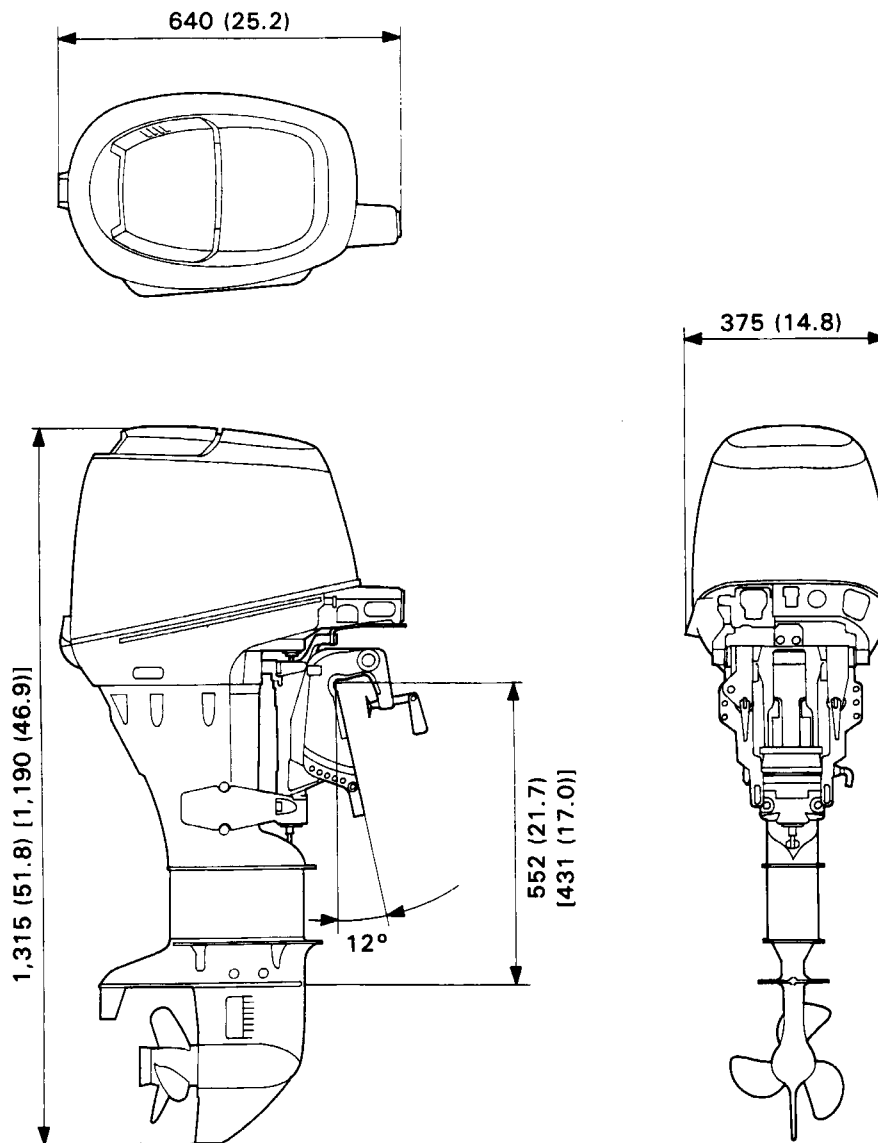

Tiller handle type
 []: Short shaft type

Unit: mm (in)

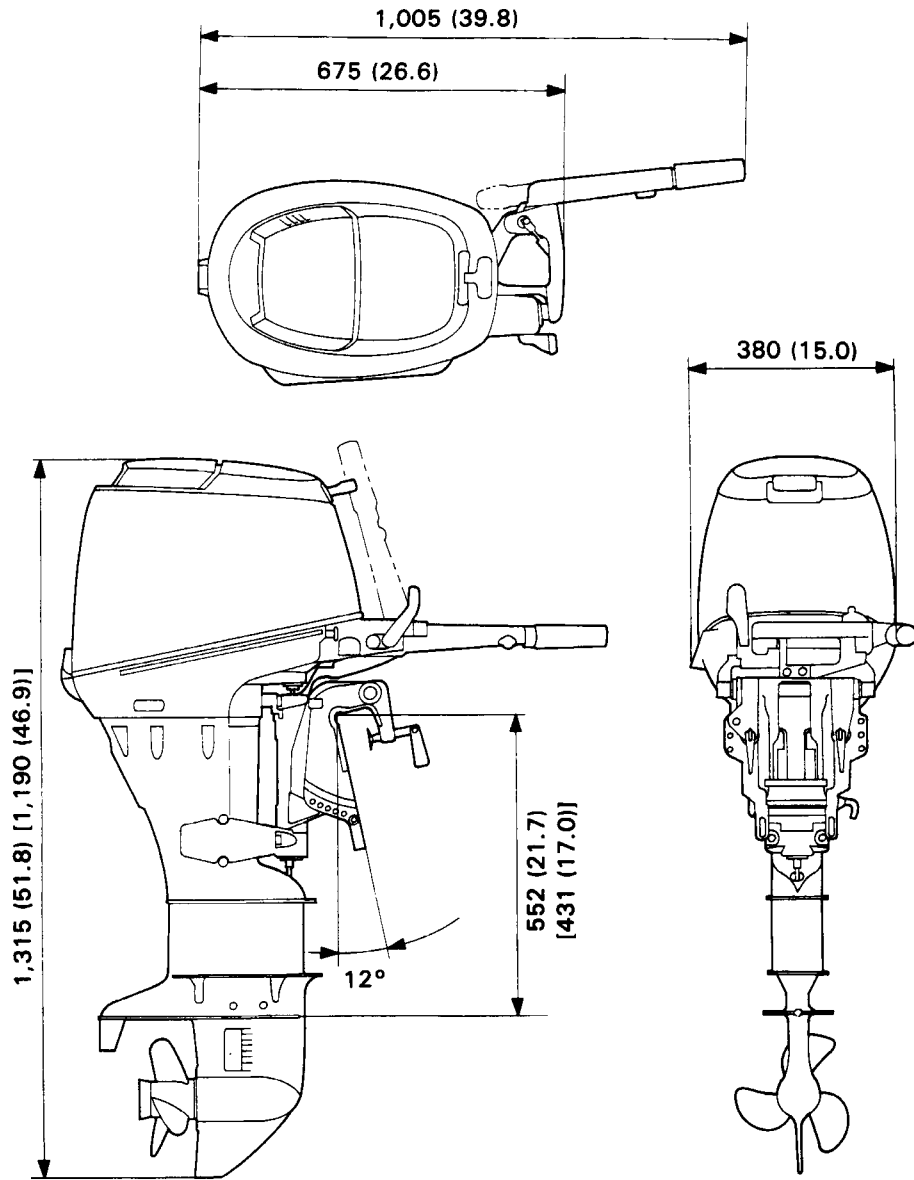

PROPELLER SHAFT

Unit: mm (in)

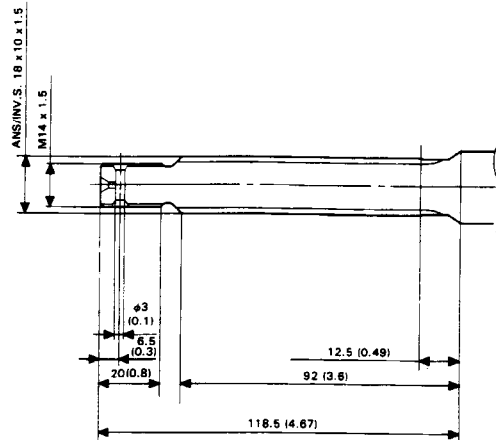

2. SERVICE INFORMATION

- | | |
|---|---|
| 1. GENERAL SAFETY | C. ELECTRIC STARTER
(Electric starter type only) |
| 2. SERVICE RULES | D. ENGINE DOES NOT RUN SMOOTHLY |
| 3. SERIAL NUMBER LOCATION | E. ALERT SYSTEMS
Oil Pressure Test |
| 4. MAINTENANCE STANDARDS | F. SHIFT LEVER |
| 5. TORQUE VALUES | 8. CABLE/HARNESS ROUTING |
| 6. SPECIAL TOOLS | 9. TUBE ROUTING |
| 7. TROUBLESHOOTING | 10. LUBRICATION |
| A. HARD STARTING
Cylinder Compression Test | 11. MAINTENANCE SCHEDULE |
| B. IGNITION SYSTEM
Spark Test | |

1. GENERAL SAFETY

Pay attention to these symbols and their meanings:

- ⚠ WARNING** Indicates a strong possibility of severe personal injury or death if instructions are not followed.
CAUTION: Indicates a possibility of personal injury or equipment damage if instructions are not followed.

⚠ WARNING

- Stop the engine, and remove the spark plug caps and ignition key before servicing the outboard motor.
- If the motor must be running to do some work, make sure the area is well ventilated. Never run the engine in a closed area; the exhaust contains poisonous carbon monoxide gas.
- Gasoline is extremely flammable and is explosive under certain conditions. Do not smoke or allow flames or sparks in your working area.

CAUTION

- Keep away from rotating or hot parts and high voltage wires when the engine is run with the engine cover off.

2. SERVICE RULES

1. Use genuine Honda or Honda-recommended parts and lubricants or their equivalents. Parts that do not meet Honda's design specifications may damage the unit.
2. Use the special tools designed for the product.
3. Install new gaskets, O-rings, etc. when reassembling.
4. When torquing bolts or nuts, begin with larger-diameter or inner bolts first and tighten to the specified torque diagonally, unless a particular sequence is specified.
5. Clean parts in cleaning solvent upon disassembly. Lubricate any sliding surfaces before reassembly.
6. After reassembly, check all parts for proper installation and operation.
7. Many screws used in this machine are self-tapping. Be aware that cross-threading or overtightening these screws will strip the female threads and ruin the hole.
8. Use only metric tools when servicing this unit. Metric bolt, nuts and screws are not interchangeable with nonmetric fasteners. The use of incorrect tools and fasteners will damage the unit.
9. Follow the instructions represented by these symbols when they are used:



: Apply oil

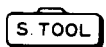

: Use special tool



: Apply grease

○ x ○ (○) : Indicates the type, length, and number of the flange bolt used.

P : Indicates the reference page.



: Use molybdenum oil solution (mixture of the engine oil and molybdenum grease with the ratio 1 : 1).

(Molybdenum
disulfide oil)

3. SERIAL NUMBER LOCATION

The engine serial number is stamped on the cylinder block and the produce identification number is located on the R. stem bracket. Always specify these numbers when inquiring about the engine or when ordering parts in order to obtain the correct parts for outboard motor being serviced.

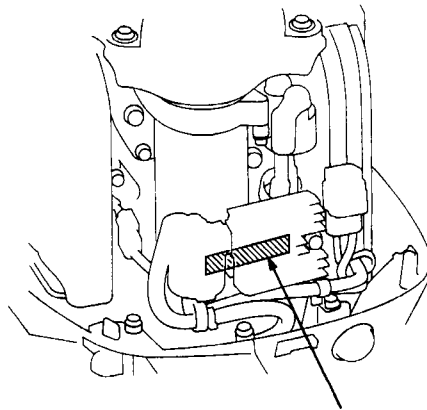

ENGINE SERIAL NUMBER

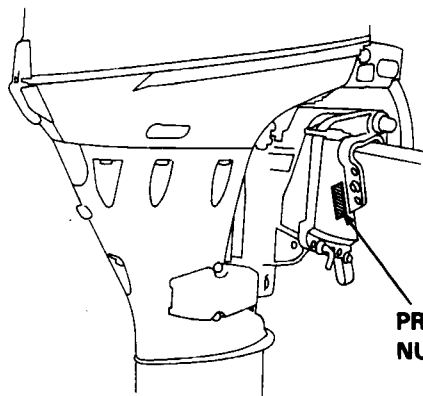

**PRODUCT IDENTIFICATION
NUMBER**

4. MAINTENANCE STANDARDS

ENGINE

Unit: mm (in)

Part	Item		Standard	Service limit
Engine	Idle speed (in neutral)		900 ± 50 min ⁻¹ (rpm)	—
	Cylinder compression		15 ± 1 kg/cm ² (212 ± 14 psi) at 500 min ⁻¹ (rpm)	—
Carburetor	Main jet		# 100	—
	Pilot screw opening		2 turns out	—
	Float height		14 (0.6)	—
Spark plug	Gap		0.6–0.7 (0.024–0.028)	—
Valves	Valve clearance	IN	0.10–0.14 (0.004–0.006)	—
		EX	0.18–0.22 (0.007–0.009)	—
	Stem O.D.	IN	5.475–5.490 (0.2156–0.2161)	5.45 (0.215)
		EX	5.455–5.470 (0.2148–0.2154)	5.43 (0.214)
	Guide I.D.	IN/EX	5.500–5.512 (0.2165–0.2170)	5.54 (0.218)
	Seat width	IN	0.9–1.1 (0.035–0.043)	2.0 (0.08)
		EX	0.9–1.1 (0.035–0.043)	2.0 (0.08)
	Spring free length	IN/EX	36.8 (1.45)	35.3 (1.39)
Stem-to-guide clearance	IN	0.010–0.037 (0.0004–0.0015)	0.07 (0.003)	
	EX	0.030–0.057 (0.0012–0.0022)	0.12 (0.005)	
Rocker arm	Rocker arm I.D.		13.000–13.018 (0.5118–0.5125)	13.04 (0.513)
	Rocker arm shaft O.D.		12.962–12.980 (0.5103–0.5110)	12.92 (0.509)
	Rocker arm shaft-to-rocker arm clearance		0.020–0.056 (0.0007–0.0022)	0.07 (0.003)
Piston	Skirt O.D.		57.970–57.990 (2.2823–2.2831)	57.92 (2.280)
	Piston-to-cylinder clearance		0.010–0.045 (0.0004–0.0018)	0.1 (0.004)
	Pin bore I.D.		14.002–14.008 (0.5513–0.5515)	14.02 (0.552)
	Pin O.D.		13.994–14.000 (0.5509–0.5512)	13.97 (0.550)
	Pin-to-pin bore clearance		0.002–0.014 (0.0001–0.0006)	0.04 (0.002)
Piston ring	Ring side clearance	Top	0.025–0.055 (0.0010–0.0022)	0.1 (0.004)
		Second	0.025–0.055 (0.0010–0.0022)	0.1 (0.004)
		Oil	0.055–0.14 (0.0022–0.006)	0.2 (0.008)
	Ring end gap	Top	0.15–0.3 (0.006–0.012)	0.5 (0.02)
		Second	0.35–0.50 (0.014–0.020)	0.7 (0.03)
		Oil	0.20–0.80 (0.008–0.031)	1.0 (0.04)
	Ring thickness	Top	1.175–1.190 (0.0463–0.0469)	1.08 (0.043)
Second		1.175–1.190 (0.0463–0.0469)	1.08 (0.043)	
Cylinder/ cylinder head	Cylinder sleeve I.D.		58.000–58.015 (2.2835–2.2841)	58.055 (2.2856)
	Distortion of cylinder head		0.05 (0.002)	0.1 (0.004)
	I.D. of camshaft journal	# 1	20.000–20.021 (0.7874–0.7882)	20.05 (0.789)
		# 2	30.000–30.025 (1.1811–1.1821)	30.06 (1.183)
		(Oil pump journal) # 3	18.000–18.027 (0.7087–0.7097)	18.06 (0.711)

Unit: mm (in)

Part	Item		Standard	Service limit
Connecting rod	Small end I.D.		14.010 – 14.022 (0.5516 – 0.5520)	14.05 (0.553)
	Big end oil clearance		0.010 – 0.028 (0.0004 – 0.0011)	0.4 (0.01)
	Big end axial clearance		0.12 – 0.27 (0.005 – 0.011)	0.4 (0.01)
	Connecting rod bearing oil clearance		0.018 – 0.042 (0.0007 – 0.0017)	0.8 (0.03)
Crankshaft	Journal O.D.	Main	35.986 – 36.002 (1.4168 – 1.4174)	35.96 (1.416)
		Pin	31.987 – 32.011 (1.2593 – 1.2603)	31.96 (1.258)
	Crankshaft main bearing oil clearance		0.020 – 0.044 (0.0008 – 0.0017)	0.06 (0.002)
	Crankshaft side clearance		0.05 – 0.30 (0.002 – 0.012)	0.45 (0.018)
Camshaft	Shaft axial clearance		0.15 – 0.40 (0.006 – 0.016)	0.6 (0.02)
	Shaft runout		0.03 (0.001) Max.	0.05 (0.002)
	Journal O.D.	# 1	19.959 – 19.980 (0.7858 – 0.7866)	19.93 (0.785)
		# 2	29.939 – 29.960 (1.1787 – 1.1795)	29.9 (1.18)
		# 3	17.966 – 17.984 (0.7073 – 0.7080)	17.94 (0.706)
	Cam height	IN	24.073 – 24.313 (0.9478 – 0.9572)	23.843 (0.9387)
		EX	24.105 – 24.345 (0.9490 – 0.9585)	23.905 (0.9411)
	Shaft oil clearance	# 1	0.020 – 0.062 (0.0008 – 0.0024)	0.08 (0.003)
		# 2	0.040 – 0.086 (0.0016 – 0.0034)	0.11 (0.004)
# 3		0.016 – 0.061 (0.0006 – 0.0024)	0.08 (0.003)	
Oil pump	Body I.D.		40.71 – 40.74 (1.603 – 1.604)	40.76 (1.605)
	Inner rotor-to-outer rotor clearance		0.15 (0.006) Max.	0.2 (0.01)
	Outer rotor-to-body clearance		0.15 – 0.21 (0.006 – 0.008)	0.26 (0.010)
	Outer rotor height		14.98 – 15.00 (0.590 – 0.591)	14.96 (0.589)
	Pump body depth		15.02 – 15.05 (0.591 – 0.593)	15.09 (0.594)
	Pump end clearance		0.02 – 0.07 (0.001 – 0.003)	0.1 (0.004)
Ignition coil	Resistance	Primary coil	0.19 – 0.23 Ω	—
		Secondary coil	10.3 – 15.9 kΩ	—
Exciter coil	Resistance		272 – 368 Ω	—
Pulser coil	Resistance		290 – 355 Ω	—

FRAME

Unit: mm (in)

Part	Item		Standard	Service limit
Vertical shaft	Shaft O.D. (at needle bearing)		22.217–22.230 (0.8747–0.8752)	22.196 (0.8739)
Bevel gear	Gear I.D.	Forward	19.000–19.021 (0.7480–0.7489)	19.04 (0.750)
		Reverse	22.05–22.30 (0.868–0.878)	22.35 (0.880)
Propeller shaft	Shaft O.D.	Front	18.967–18.980 (0.7467–0.7472)	18.946 (0.7459)
		Rear	20.9–21.2 (0.82–0.83)	20.85 (0.821)
	Shaft O.D. (at needle bearing)		22.007–22.020 (0.8664–0.8669)	21.99 (0.866)

5. TORQUE VALUES

Item	Thread Dia. (mm) and pitch (length)	Torque values			
		N·m	kg-m	ft-lb	
• ENGINE					
Crankcase bolt	*1	M8 x 1.25	29	2.9	21.0
		M6 x 1.0	12	1.2	8.7
Oil filter cartridge		M20 x 1.5	11	1.1	8.0
Water jacket cover bolt		M6 x 1.0	12	1.2	8.7
Thermostat cover bolt		M6 x 1.0	12	1.2	8.7
Cylinder head bolt	*1	M8 x 1.25	29	2.9	21.0
		M8 x 1.25	27	2.7	19.5
Cylinder head cover bolt		M6 x 1.0	12	1.2	8.7
Fuel pump bolt		M6 x 1.0	10	1.0	7.2
Throttle cam		M6 x 1.0	12	1.2	8.7
Choke arm bolt		M6 x 1.0	12	1.2	8.7
Intake manifold bolt, nut		M6 x 1.0	12	1.2	8.7
Carburetor bolt		M6 x 1.0	10	1.0	7.2
Connecting rod nut		M7 x 0.75	24	2.4	17.4
Valve adjusting nut		M5 x 0.5	8	0.8	5.8
Oil drain bolt		M12 x 1.5	23	2.3	16.6
Exhaust pipe bolt		M6 x 1.0	10	1.0	7.2
Oil pan bolt		M6 x 1.0	10	1.0	7.2
Oil pump bolt		M6 x 1.0	13	1.3	9.4
Oil strainer bolt		M6 x 1.0	13	1.3	9.4
Timing pulley nut		M34 x 1.0	65	6.5	47.0
Timing belt tensioner bolt		M10 x 1.25	44	4.4	31.8
Timing belt adjusting spring bolt		M6 x 1.0	12	1.2	8.7
Flywheel nut		M16 x 1.5	115	11.5	83.2
Cam pulley bolt		M8 x 1.25	27	2.7	19.5
Oil pressure switch		PT 1/8	9	0.9	6.5
Thermo switch		M16 x 1.5	12	1.2	8.7
Starter solenoid cable					
(starter solenoid side)		M6 x 1.0	5	0.5	3.6
(electric starter side)		M8 x 1.25	27	2.7	19.5
CDI unit bolt		M6 x 1.0	5	0.5	3.6
Choke solenoid bracket bolt					
(Remote control type only)		M6 x 1.0	9	0.9	6.5

*1: Tighten the crankcase bolts to 29 N·m (2.9 kg-m, 21.0 ft-lb) and the cylinder head bolts to 29 N·m (2.9 kg-m, 21.0 ft-lb) first, then tighten them an additional $90^{\circ} +_{0}^{30}$.

Item	Thread Dia. (mm) and pitch (length)	Torque values		
		N·m	kg-m	ft-lb
•GEAR CASE				
Pinion gear nut	M10×1.0	40	4.0	28.9
Gear case bolt	M10×1.25	35	3.5	25.3
Oil check plug	M8 × 1.25	3.5	0.35	2.5
Oil drain plug	M8 × 1.25	3.5	0.35	2.5
Wash plug	M8 × 1.25	3.5	0.35	2.5
Impeller housing bolt	M6 × 1.0	11	1.1	8.0
Propeller shaft castle nut	M14 × 1.5	1	0.1	0.7
•EXTENSION/MOUNT				
Extension case bolt	M8 × 1.25	22	2.2	15.9
Lower rubber motor mount nut	M12×1.25	55	5.5	39.8
Lower motor mount housing nut	M8 × 1.25	22	2.2	15.9
Upper rubber motor mount nut	M10×1.25	45	4.5	32.5
•STERN BRACKET				
Stern bracket nut (L.side)	7/8-14 UNF	17.5	1.75	12.7
(R.side)	7/8-14 UNF	32.5	3.25	23.5
	M8 × 1.25	22	2.2	15.9
•FRAME/ELECTRICAL				
Emergency stop switch nut	M16×1.0	1.5	0.15	1.1
Starter button nut (tiller handle type only)	M16×1.0	1.5	0.15	1.1
Water hose joint	PT1/8	9	0.9	6.5
Sampling probe cap (Bodensee type only)	M14 × 1.25	5	0.5	3.6
Sampling probe pipe (Bodensee type only)	M14 × 1.25	20	2.0	14.5

*1: First, tighten to the specified torque. If the cotter pin does not set in the hole, tighten additionally until the cotter pin sets in the hole securely.

Specified torque: 1 N·m (0.1 kg-m, 0.7 ft-lb)

Maximum torque: 35 N·m (3.5 kg-m, 25.3 ft-lb)

NOTE: Use standard torque values for fasteners that are not listed in this table.

STANDARD TORQUE VALUES

Item	Thread Dia.	Torque values		
		N·m	kg-m	ft-lb
Bolt and nut	5 mm	5	0.5	3.6
	6 mm	10	1.0	7.2
	8 mm	21	2.1	15.2
	10 mm	35	3.5	25.3
	12 mm	55	5.5	39.8
Flange bolt and nut	6 mm (SH Flange bolt)	9	0.9	6.5
	6 mm	12	1.2	8.7
	8 mm	27	2.7	19.5
	10 mm	35	3.5	25.3
	12 mm	60	6.0	43.4
Screw	5 mm	4	0.4	2.9
	6 mm	9	0.9	6.5

6. SPECIAL TOOLS

Tool name	Tool number	Application
1. Float level gauge	07401-0010000	Inspection for carburetor float level
2. Oil pressure gauge	07506-3000000	Inspection for oil pressure
2-1. -attachment	07406-0030000	
3. Torx bit handle	07703-0010300	Handle for 3-1
3-1. -screw T20H	07703-0010400	Fuel pump disassembly/reassembly
4. Valve guide driver, 5.5 mm	07742-0010100	Valve guide removal/installation
5. Pin driver, 2.5 mm	07744-0010100	2.5 x 22 mm, 2.5 x 25 mm spring pin, 25 x 13.8 mm roller removal/installation
6. Pin driver, 3.0 mm	07744-0010200	3 x 20 mm, 3 x 25 mm spring pin removal/installation
7. Attachment, 32 x 35 mm	07746-0010100	22 x 35 x 7 mm water seal, lower motor mount center housing installation
8. Attachment, 37 x 40 mm	07746-0010200	Gear case inner race installation
9. Attachment, 42 x 47 mm	07746-0010300	Vertical shaft outer race installaiton
10. Attachment, 62 x 68 mm	07746-0010500	Gear case outer race installation
11. Attachment, 24 x 26 mm	07746-0010700	7/8 x 1-1/8 x 1 mm needle bearing installation, reverse gear removal/installation, 17 x 26 x 7 mm water seal installation
12. Attachment, 35 mm I.D.	07746-0030400	32 x 58 x 13 mm bearing, gear case inner race installation
13. Pilot, 22 mm	07746-0041000	7/8 x 1-1/8 x 1 mm removal/installation, 22 x 28 x 20 mm needle bearing installation
14. Oil seal driver	07748-0010001	Oil seal, water seal removal
15. Driver	07749-0010000	Driver for 7, 8, 9, 10, 11 and 31
16. Valve spring compressor	07757-0010000	Valve keeper removal/installation
17. Valve seat cutter, 45° φ24.5	07780-0010100	Valve seat reconditioning EX
18. Valve seat cutter, 45° φ29	07780-0010300	Valve seat reconditioning IN
19. Valve seat cutter, 32° φ25	07780-0012000	Valve seat reconditioning EX
20. Valve seat cutter, 32° φ28	07780-0012100	Valve seat reconditioning IN
21. Valve seat cutter, 60° φ30	07780-0014000	Valve seat reconditioning IN
22. Valve seat cutter, 60° φ26	07780-0014500	Valve seat reconditioning EX
23. Cutter holder, 5.5 mm	07781-0010101	Valve seat reconditioning
24. Valve guide reamer	07984-2000001	Valve guide reaming
25. Valve adjusting screw	07908-KE90000	Valve clearance adjustment
26. Crankshaft holder	07923-ZA00100	34 mm lock nut removal/installation
27. Holder	07926-VA20001	Flywheel removal/installation
28. Pin driver, 4 mm	07944-9350200	4 x 22 mm, 4 x 28 mm spring pin removal/installation
29. Remover weight	07741-0010201	Constituents of Bearing race puller (item 41).
30. Remover handle	07936-3710100	
31. Attachment, 28 x 30 mm	07946-1870100	22 x 28 x 20 mm needle bearing, 17 x 30 x 7 mm water seal installation
32. Stem race driver	07946-GC40000	Vertical shaft inner race installation
33. Driver head	07946-KM40701	22 x 28 x 20 mm needle bearing installation
34. Driver shaft	07946-MJ00100	22 x 28 x 20 mm needle bearing installation

Tool name	Tool number	Application
35. Support base	07965-SD90100	Reverse gear removal
36. Remover attachment, 22 mm I.D.	07GMD-KT70200	Reverse gear removal
37. Driver	07949-3710001	7/8 x 1-1/8 x 1 mm needle bearing removal/installation, gear case outer race installation, reverse gear removal
38. Oil filter wrench	07HAA-PJ70100	Oil filter replacing
39. Vertical shaft holder	07LPB-ZV30200	Vertical shaft lock nut removal/installation
40. Propeller shaft holder	07LPB-ZV30300	Forward gear backlash inspection
41. Bearing race puller	07LPC-ZV30100	Vertical shaft, gear case outer race, 32 x 58 x 13 mm bearing removal
42. Bearing height gauge	07LPJ-ZV30200	Forward gear shim adjustment
43. Backlash inspection attachment	07MGJ-0010100	Forward/reverse gear backlash inspection
44. Vertical shaft gauge	07PPJ-ZV70100	Vertical shaft shim adjustment
45. Propeller shaft gauge	07PPJ-ZV70200	Propeller shaft shim adjustment
46. Test propeller	07PPZ-ZV70100	For test operation in water tank
47. Pilot screw wrench	07KMA-MS60101	Pilot screw adjustment (Bodenss type only)

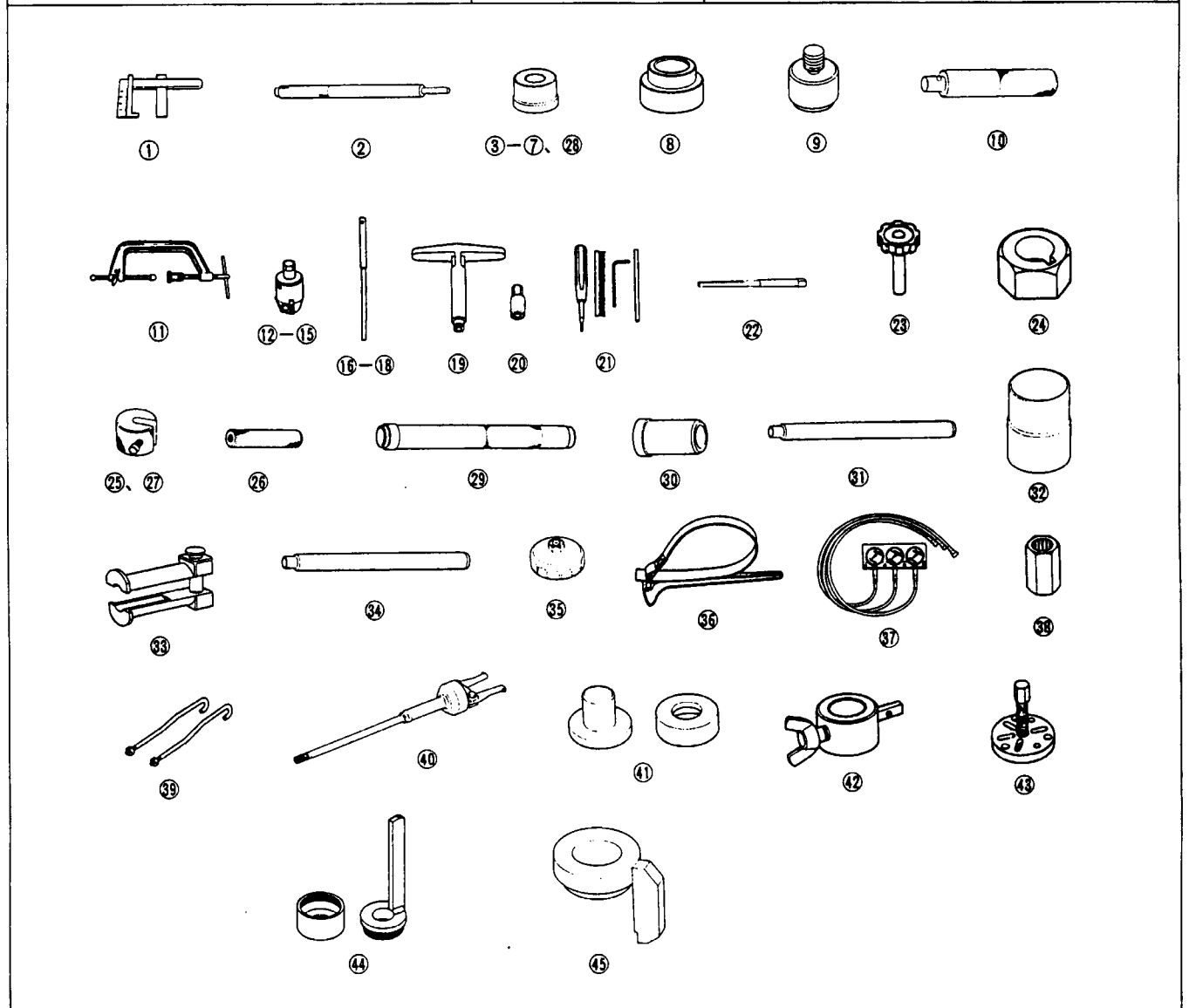

7. TROUBLESHOOTING

ENGINE

A. HARD STARTING

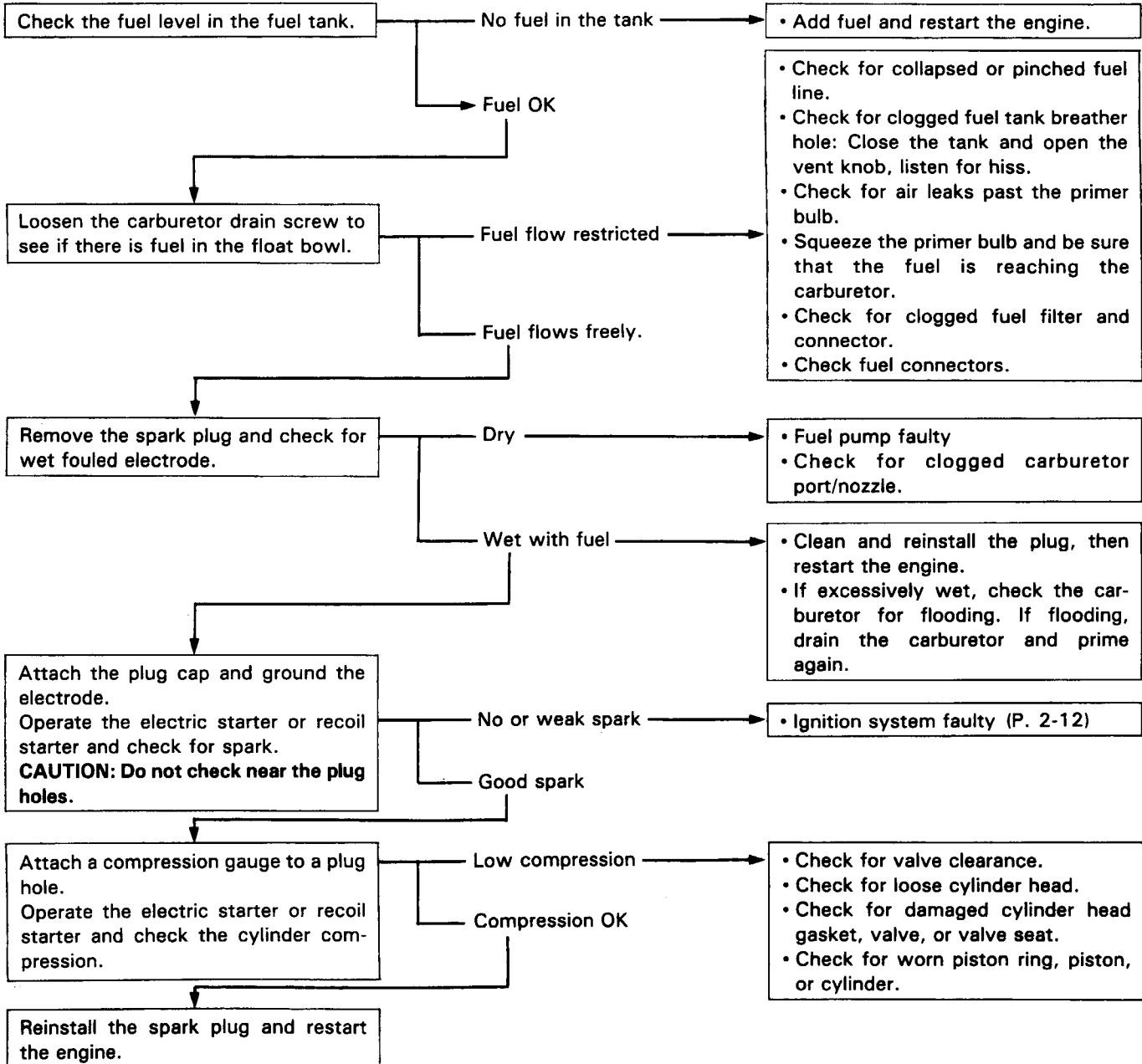

CYLINDER COMPRESSION

- 1) Put the remote control lever or gearshift lever in the neutral position.
- 2) Disengage the emergency stop switch clip from the emergency stop switch.
- 3) Put the choke knob or choke/fast idle lever in the normal run position.
- 4) Remove the engine cover and all the spark plug caps. Remove the all spark plugs.
- 5) Carefully disconnect the throttle rod from the throttle cam (P. 3-10).
- 6) Install a compression gauge in one of the spark plug holes.
- 7) Manually hold the throttle cam in the wide open throttle position.
- 8) Using the ignition key, starter button, or recoil starter, operate the starter until the highest compression reading is obtained.

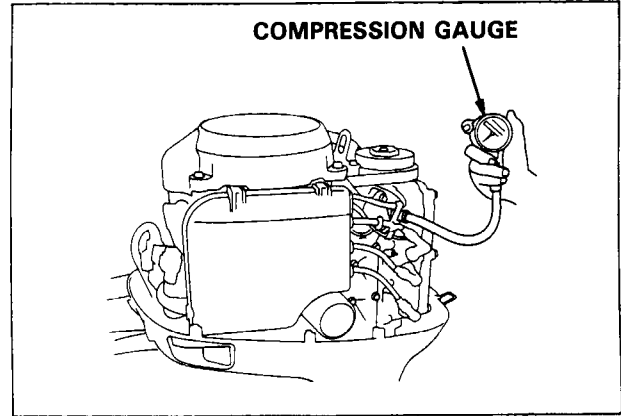

Cylinder compression	$15 \pm 1 \text{ kg/cm}^2$ (212 – 14 psi) at 500 min^{-1} (rpm)
----------------------	--

NOTE

- On the remote control type, have an assistant operate the electric starter using the ignition key.
- 9) Install the compression gauge in the other spark plug holes and repeat step 7) and 8).
 - 10) Check the compression on all cylinders.

B. IGNITION SYSTEM

