

Workshop Manual

"HU" Models

Early "NC" Models

Electrical & Ignition

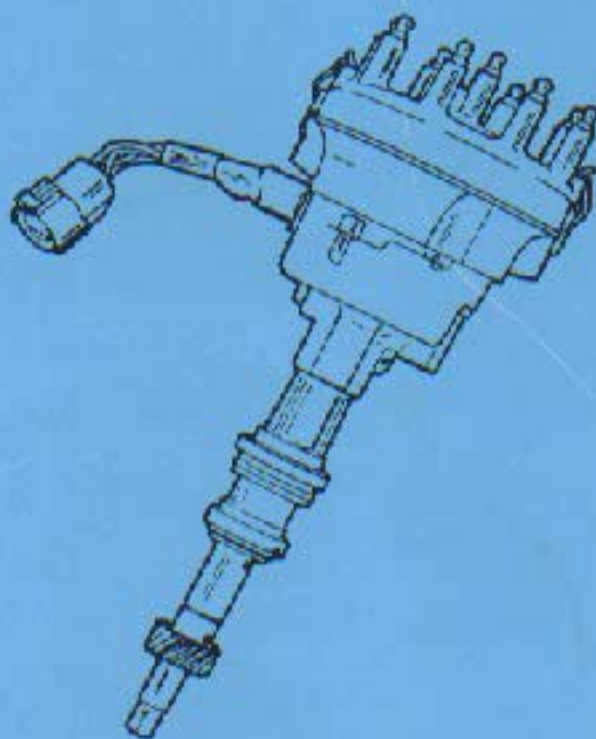
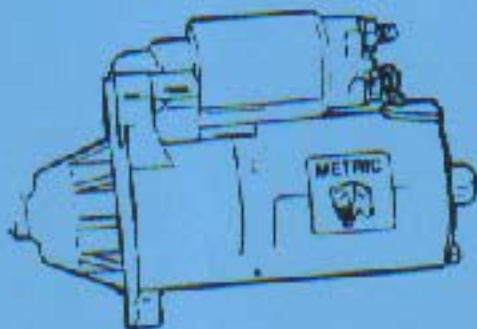
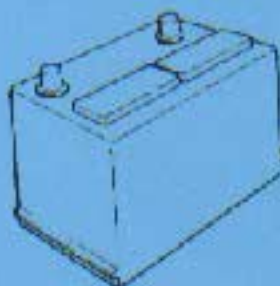
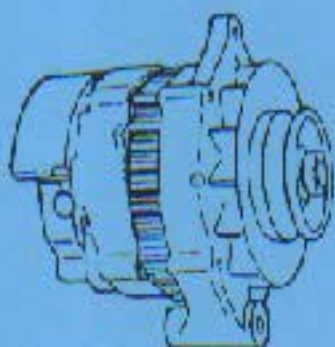

Safety Warning

This Workshop Manual will alert you to certain procedures that must be done very carefully. If you ignore this information, you could...

- Injure yourself or people around you
- Injure the boat operator, boat passengers, or people around the boat
- Damage the Volvo Penta product or its systems

Understand the following symbols before proceeding:

 Safety Warning	Alerts you to the possibility of danger and identifies information that will help prevent injuries.
Note	Identifies information that will help prevent damage to machinery.
Important	Appears next to information that controls correct assembly and operation of the product.

This Workshop Manual is written for qualified, factory trained service technicians familiar with the use of Volvo Penta special tools.

This Workshop Manual tells you how to correctly maintain and service Volvo Penta products and systems. When correctly serviced, the Volvo Penta product will be reliable and safe to operate.

When Volvo Penta special tools are called for, use them. Where mentioned, the tools are required to perform the service procedure.

If you use service procedures or service tools that are not recommended in this manual, **YOU ALONE** must decide if your actions might injure people or damage the Volvo Penta product.

Contents

1	General Information
2	Cranking System
3	Charging System
4	Trim/Tilt System - Electrical - SX Models
5	3.0, 4.3 GL, GS and 5.7 GI Ignition System
6	5.7, 7.4 and 8.2 GL, 5.0 and 5.8 FL Ignition System
7	5.0, 5.8 FI Ignition System
8	5.0, 5.8 FI Electrical System
9	Electrical System Wiring Diagrams
S	Safety

This workshop manual is one of a set of nine that covers *Volvo Penta* stern drive models. All nine books can be ordered as a set from *Volvo Penta Parts*. Order P/N 7788850-1.

Individual workshop manuals covering these models are also available. Order the following part numbers from *Volvo Penta Parts*.

- **P/N 7788851-9 *SX Drive Unit and Transom Shield***

Includes information on Transom Shield, Upper Gear Unit and Lower Gear Unit service; Drive Unit removal and installation; Propellers; and Trim/Tilt hydraulic operation.

- **P/N 7788856-8 *Engine Components***

Includes information on Engine service and troubleshooting; Engine removal and installation; Steering systems; Throttle and Shift Control systems; and Cooling systems.

- **P/N 7788857-6 *Electrical & Ignition System***

Includes service and troubleshooting information on Cranking systems; Charging systems; Trim/Tilt electrical systems; Ignition systems; and Engine and Instrument wiring diagrams.

- **P/N 7788858-4 *Fuel System***

Includes service and troubleshooting information on all carburetor, MFI and TBI fuel systems and related components.

- **P/N 7788852-7 *MFI Diagnostic Manual (5.0 Fi, 5.8 Fi/FS) - Ford***

Includes step by step troubleshooting procedures for all MFI Ford related components and wiring.

- **P/N 7788853-5 *TBI Diagnostic Manual (4.3 Gi, 5.7 Gi) - GM***

Contains troubleshooting procedures for all TBI GM models and related components.

- **P/N 7788855-0 *SP and DP Workshop Manual***

Includes Upper Gear Unit and Lower Gear Unit overhaul procedures, installation and removal.

- **P/N 7788854-3 *MFI Diagnostic Manual (7.4 Gi, 7.4 GSi) - GM***

Includes step by step troubleshooting procedures for all MFI GM related components and wiring.

- **P/N 7788859-0 *DPX - Lower Unit Workshop Manual***

Includes specific information for repair and overhaul of the DPX Lower unit and Xact™ steering systems not covered in the SP and DP Workshop manual.

This Volvo Penta Stern Drive Workshop Manual Covers The Following Volvo Penta "HU" Models

SX™

Engine	Model Nr.	Transom Shield	Drive Unit	Options
3.0 GS SX NPS	3868181	3868288/SX-LIMITED TRIM	3868159/SX-CT/1.85:1	3868176/SX-C
3.0 GS SX	3868182	3868288/SX-LIMITED TRIM	3868159/SX-CT/1.85:1	3868176/SX-C
4.3 GL SX	3868184	3868176/SX-C	3868160/SX-C/1.66:1	3868159/SX-C/1.85:1/H.A.
4.3 GS SX	3868186	3868176/SX-C	3868160/SX-C/1.66:1	3868159/SX-C/1.85:1/H.A.
5.0 FL SX	3868189	3868176/SX-C	3868160/SX-C/1.66:1	3868159/SX-C/1.85:1/H.A.
5.0 FI SX	3868193	3868176/SX-C	3868161/SX-C/1.60:1	3868160/SX-C/1.66:1/H.A.
5.8 FL SX	3868190	3868176/SX-C	3868162/SX-C/1.51:1	3868160/SX-C/1.66:1/H.A.
5.8 FI SX	3868194	3868176/SX-C	3868162/SX-C/1.51:1	3868160/SX-C/1.66:1/H.A.
5.8 FSI SX	3868196	3868176/SX-C	3868208/SX-C/1.43:1	3868162/SX-C/1.51:1/H.A.

DuoProp®

Engine	Model Nr.	Transom Shield	Drive Unit	Options
4.3 GL DP	3868320	3868299/DP-S	3868008/DP-C/1/2.30:1	
4.3 GS DP	3868321	3868299/DP-S	3868008/DP-C/1/2.30:1	
5.0 FL DP	3868322	3868299/DP-S	3868002/DP-C/1/1.95:1	
5.0 FI DP	3868323	3868299/DP-S	3868002/DP-C/1/1.95:1	
6.7 GI DP	3868325	3868299/DP-S	3868002/DP-C/1/1.95:1	
6.8 FL DP	3868324	3868299/DP-S	3868002/DP-C/1/1.95:1	
5.8 FI DP *	3868326	3868299/DP-S	3868002/DP-C/1/1.95:1	
6.8 F8I DP	3868327	3868299/DP-S	3868002/DP-C/1/1.95:1	
7.4 GL DP	3868328	3868299/DP-S	3868022/DP-D/1/1.78:1	
7.4 GI DP	3868335	3868299/DP-S	3868022/DP-D/1/1.78:1	N.A.

H.A. = high altitude applications

N.A. = Not Available

DPX™

Engine	Model Number	Transom Shield	Drive Unit
4.3 GI DP	3868320	3868299/DP-S	3868008/DP-C/1/2.30:1
4.3 GS DP	3868321	3868299/DP-S	3868008/DP-C/1/2.30:1
5.0 FL DP	3868322	3868299/DP-S	3868002/DP-C/1/1.95:1
5.0 FI DP	3868323	3868299/DP-S	3868002/DP-C/1/1.95:1
6.7 GI DP	3868325	3868299/DP-S	3868002/DP-C/1/1.95:1
6.8 FL DP	3868324	3868299/DP-S	3868002/DP-C/1/1.95:1
5.8 FI DP *	3868326	3868299/DP-S	3868002/DP-C/1/1.95:1
6.8 F8I DP	3868327	3868299/DP-S	3868002/DP-C/1/1.95:1
7.4 GL DP	3868328	3868299/DP-S	3868022/DP-D/1/1.78:1
7.4 GI DP	3868335	3868299/DP-S	3868022/DP-D/1/1.78:1

* = export only

7.4 GSI DPX-CA	3868198	3868289/DPX-C	3868020/DPX-C/1.59:1
7.4 GSI DPX-CB	3868198	3868289/DPX-C	3868021/DPX-C/1.68:1
7.4 GSI DPX-CC	3868198	3868289/DPX-C	3868023/DPX-C/1.78:1
8.2 GL DPX-CA	3868133	3868289/DPX-C	3868020/DPX-C/1.59:1
8.2 GL DPX-CB	3868133	3868289/DPX-C	3868021/DPX-C/1.68:1
8.2 GL DPX-CC	3868133	3868289/DPX-C	3868023/DPX-C/1.78:1

This *Volvo Penta* Stern Drive Workshop Manual Covers The Following *Volvo Penta* "NC" Models

SX™

Engine	Model Nr.	Transom Shield	Drive Unit	Options
3.0 GS SX NPS	3868181	3868432/SX-LIMITED TRIM	3868396/SX-CT/1.85:1	3868397/1.97/SXC 386404/TSK
3.0 GS SX	3868182	3868432/SX-LIMITED TRIM	3868396/SX-CT/1.85:1	3868397/1.97/SXC 386404/TSK
4.3 GL SX	3868184	3868404/SX/DP	3868395/SX/1.66	3868465/SX/1.85
4.3 GS SX	3868186	3868404/SX/DP	3868395/SX/1.66	3868465/SX/1.85
5.0 FL 9X	3868414	3868404/SX/DP	3868395/SX/1.66	N.A.
5.0 FI SX	3868416	3868404/SX/DP	3868394/SX/1.60	3868395/SX/1.66
5.7 GI SX	3868429	3868404/SX/DP	3868393/SX/1.51	N.A.
5.8 FL 8X	3868415	3868404/SX/DP	3868393/SX/1.51	N.A.
5.8 FSi SX	3868418	3868404/SX/DP	3868393/SX/1.51	N.A.

H.A. = high altitude applications

DuoProp®

Engine	Model Nr.	Transom Shield	Drive Unit	Options
4.3 GL DP	3868184	3868404/SX/DP	3868163/DP/2.30	N.A.
4.3 GS DP	3868186	3868404/SX/DP	3868163/DP/2.30	N.A.
4.3 GI DP	3868185	3868404/SX/DP	3868163/DP/2.30	N.A.
5.0 FL DP	3868414	3868404/SX/DP	3868164/DP/1.95	N.A.
5.0 FI DP	3868416	3868404/SX/DP	3868164/DP/1.95	N.A.
5.7 GI DP	3868429	3868404/SX/DP	3868164/DP/1.95	N.A.
5.8 FL DP	3868415	3868404/SX/DP	3868164/DP/1.95	N.A.
5.8 FSi DP	3868418	3868404/SX/DP	3868164/DP/1.95	3868165/DP/1.78
7.4 GL DP	3868196	3868404/SX/DP	3868022/DP-D1/1.78:1	N.A.
7.4 GI DP	3868450	3868404/SX/DP	3868166/DP/1.68	N.A.

* = for export only

H.A. = high altitude applications

N.A. = Not Available

DPX™

Engine	Model Nr.	Transom Shield	Drive Unit
7.4 GSi DPX-CA	3868198	3868289/DPX	3868020/DPX /1.59:1
7.4 GSi DPX-CB	3868198	3868289/DPX	3868021/DPX /1.68:1
7.4 GSi DPX-CC	3868198	3868289/DPX	3868023/DPX /1.78:1
8.2 GL DPX-CA	3868133	3868289/DPX	3868020/DPX /1.59:1
8.2 GL DPX-CB	3868133	3868289/DPX	3868021/DPX /1.68:1
8.2 GL DPX-CC	3868133	3868289/DPX	3868023/DPX /1.78:1

Section 1

General Information

Table of Contents

Battery and Cables	1-14
Circuit Protection	1-18
Circuit Protectors and Locations	1-19
Connector Service	
Amphenol	1-25
Packard	1-27
Conversion Charts	
Drill	1-37
Metric	1-36
Engine Compression Testing	1-5
Ignition Switch	1-24
Inspection Chart	1-39
Introduction	1-2
Oil and Water Sending Units	1-20
Relays	1-17
Solenoids	1-15
Spark Plugs and Leads	1-22
Symbols	1-38
Torque Specifications, General	1-13
Troubleshooting	
System Isolation	1-28
Engine Troubleshooting Guides	1-29
Tachometer	1-24
Tune-up Specifications	1-8
Tuning the Engine	1-4
20-Hour Check	1-13

⚠ Safety Warning

Before working on any part of the electrical system, read the section called Safety at the end of this manual.

The original mounting, support and routing of electrical system parts conform with U.S. Coast Guard requirements. It is important to maintain the original mounting, support and routing after servicing the electrical system to prevent possible fire and explosion in boat's engine compartment.

Do not substitute automotive parts. *Volvo Penta* marine components meet U.S. Coast Guard regulations for external ignition proof operation and marine use. *Volvo Penta* marine components are specially designed not to cause ignition of fuel vapors in the bilge or engine compartment. The use of automotive parts can result in fire and explosion.

Introduction

This workshop manual covers *Volvo Penta* stern drive models. It is divided into sections concerning various systems and assemblies. Refer to the **Contents** to locate the section covering the system or assembly requiring service. Each section title page has an additional listing that will describe the section's contents in more detail. Be sure to read the **Safety Section** at the end of this manual, and pay special attention to all safety warnings as they appear throughout the text. Since models are subject to change at any time, some photos may not depict actual product.

Good Service Practice

Service required for *Volvo Penta* stern drives is generally one of three kinds:

- **Normal care and maintenance** - which includes putting a new stern drive into operation, storing engines, lubrication, and care under special operating conditions such as salt water and cold weather.
- **Operating malfunctions** - due to improper engine or drive mounting, propeller condition or size, boat condition, or the malfunction of some part of the engine. This includes engine servicing procedures to keep the engine in prime operating condition.
- **Complete disassembly and overhaul** - such as major service or rebuilding a unit.

It is important to determine before disassembly just what the trouble is and how to correct it quickly, with minimum expense to the owner.

When repairing an assembly, the most reliable way to ensure a good job is to do a complete overhaul on that assembly, rather than just to replace the bad part. Wear not readily apparent on other parts could cause malfunction soon after the repair job. Repair kits and seal kits contain all the parts needed to ensure a complete repair, to eliminate guesswork, and to save time.

Repair time can also be minimized by the use of special tools. *Volvo Penta* special tools are designed to perform service procedures unique to the product that cannot be completed using tools from other sources. They also speed repair work to help achieve service flat rate times. In some cases, the use of substitute tools can damage the part.

Note Do not operate engine out of water even momentarily. If operated in test tank, use proper test wheel. Failure to do so can damage water pump, overheat engine, or allow excessive engine RPM.

Preparation for Service

Proper preparation is extremely helpful for efficient service work. A clean work area at the start of each job will minimize tools and parts becoming misplaced. Clean an engine that is excessively dirty before work starts. Cleaning will occasionally uncover trouble sources. Obtain tools, instruments and parts needed for the job before work is started. Interrupting a job to locate special tools or repair kits is a needless delay.

 Use proper lifting and handling equipment. Working on stern drives without proper equipment can cause damage and personal injury.

Always use clean fresh fuel when testing engines. Troubles can often be traced to the use of old or dirty fuel.

Service Policy

Whether within or following the warranty period, *Volvo Penta* has a constant interest in their products.

It is *Volvo Penta's* policy to provide dealers with service knowledge so they can give professional service demanded by today's consumer. The *Volvo Penta* Training Centers, frequent mailing of Service Bulletins, Letters and Promotions, Special Tools and this Workshop Manual represent *Volvo Penta's* efforts to assist dealers in giving consumers the best and most prompt service possible. This Workshop Manual covers all phases of servicing the *Volvo Penta* stern drive unit. If a service question does not appear to be answered in this manual, you are invited to write to the *Volvo Penta* Service Department for additional help. Always be sure to give complete information, including engine model number and serial number.

Be sure that you are familiar with *Volvo Penta's* Warranty. If you have any questions, write the *Volvo Penta* Service Department. If other than genuine *Volvo Penta* replacement components or parts are used, *Volvo Penta* may refuse subsequent warranty claims involving that engine.

When a brand-name product or specific tool is called for, another item may be used. However, the substitute must have equivalent characteristics, including type, strength, and material. You must determine if incorrect substitution could result in product malfunction and personal injury to anyone. To avoid hazards, equivalent products which are used must meet all current U.S. Coast Guard Safety Regulations and ABYC standards.



Replacement Parts

 When replacement parts are required, always use genuine *Volvo Penta* parts, or parts with equivalent characteristics, including type, strength, and material. Failure to do so may result in product malfunction and possible injury to the operator and/or passengers.

Parts Catalogs

Parts Catalogs contain exploded views showing the correct assembly of all parts, as well as a complete listing of the parts for replacement. These catalogs are helpful as a reference during disassembly and reassembly, and are available from *Volvo Penta Parts*.

Special Service Tools

Volvo Penta has specially designed tools to simplify some of the disassembly and assembly operations. These tools are illustrated in this Workshop Manual, in many cases in actual use. All *Volvo Penta* special tools can be ordered from *Volvo Penta Parts* division. Individual purchasers of Workshop Manuals must order Special Tools through an authorized dealer.

Product References, Illustrations & Specifications

Volvo Penta reserves the right to make changes at anytime, without notice, in specifications and models and also to discontinue models. The right is also reserved to change any specifications or parts at any time without incurring any obligation to equip same on models manufactured prior to date of such change. All information, illustrations and specifications contained in this manual are based on the latest product information available at the time of printing. The right is reserved to make changes at anytime without notice.

All photographs and illustrations used in this manual may not depict actual models or equipment, but are intended as representative views for reference only. The continuing accuracy of this manual cannot be guaranteed.

Tuning The Engine

The purpose of an engine tune-up is to restore power and performance that has been lost through wear, corrosion or deterioration of one or more parts or components. In the normal operation of an engine, these changes can take place gradually at a number of points, so that it is seldom advisable to attempt an improvement in performance by correction of one or two items only. Time will be saved and more lasting results will be obtained by following a definite and thorough procedure of analysis and correction of all items affecting power and performance.



Economical, trouble-free operation can better be ensured if a complete tune-up is performed once every year, preferably in the spring. Components that affect power and performance can be divided into three groups:

- Components affecting compression
- Components affecting ignition
- Components affecting fuel system

Tune-up procedures should cover these groups in the order given. While the items affecting compression and ignition may be handled according to personal preference, correction of items in the fuel system group should not be attempted until all items affecting compression and ignition have been satisfactorily corrected. Most of the procedures for performing a complete engine tune-up will be covered in greater detail in this manual. This section will deal mainly with the order of procedures involved in tuning the engine.

Engine Compression Testing

⚠ During all work done around the engine, while the engine is running or being cranked, use extreme care to avoid getting fingers or clothing caught in any belts, pulleys, or other moving parts.

⚠ 1. Visually inspect stern drive unit for leaks, missing parts or other obvious defects. Replace deteriorated parts.

2. Compression check: Proper compression is essential for good engine performance. An engine with low or uneven compression cannot be properly tuned.

a. Operate engine to normal operating temperature.

Note Engine must not be started and run without water for cooling.



b. Remove any foreign matter from around spark plugs by blowing out with compressed air.

c. Remove and inspect all spark plugs. Install thread-type compression gauge in spark plug hole.



d. **To Prevent Sparking:**

- 3.0 GL, GS and 4.3 GL, GS models - **remove (pink and brown) 2-wire connector from distributor.**
- 5.7, 7.4 and 8.2 GL, 5.0 and 5.8 FL Models - **remove both distributor primary wires from the ignition coil, and tape wire terminals to prevent accidental grounding.**
- 5.7 Gi Models - **remove (pink and brown) 2-wire connector from distributor.**
- 5.0 and 5.8 Fi Models - **Unplug 2-way connector at ignition coil.**

e. With choke and throttle plates wide open, crank engine through at least four compression strokes; Carbureted Models only.

Test Conclusion

The indicated compression pressures are considered normal if the lowest reading cylinder is within 75% of the highest.

Example:

If the highest pressure reading was 140 PSI, 75% of 140 is 105. Therefore, any cylinder reading less than 105 PSI indicates an improperly seated valve, worn valve guides or worn or broken piston rings. Any cylinder reading 105 PSI or greater is within specifications, and compression is considered normal.

If one or more cylinders read low, squirt approximately one tablespoon of engine oil on top of the pistons in the low reading cylinders. Repeat compression pressure check on the cylinders.

1. If compression improves considerably, the piston rings are at fault.

2. If compression does not improve, valves are sticking or seating poorly, or valve guides are worn.

3. If two adjacent cylinders indicate low compression pressures and squirting oil on the pistons does not increase the compression, the cause may be a cylinder head gasket leak between the cylinders. This problem could allow engine oil and/or coolant to enter the cylinders.



It is recommended the following quick reference chart be used when checking cylinder compression pressures. The chart has been calculated so that the lowest reading number is 75% of the highest reading.

Compression Pressure Limit Chart

Max. PSI		Min. PSI		Max. PSI		Min. PSI	
134	101	174	131	115	154	145	194
140	105	180	135	120	160	150	200
142	107	182	136	121	162	151	202
144	108	184	138	123	164	153	204
146	110	186	140	124	166	154	206
148	111	188	141	126	168	156	208
150	113	190	142	127	170	157	210
152	114	192	144	129	172	158	212

After checking cylinder compression, repairs should be made as necessary. Subsequent adjustments to an engine that does not have proper compression will not measurably improve performance or correct operational problems. After verifying compression, check ignition and fuel system components.

Ignition System

- Spark Plugs
- Spark Plug Leads
- Distributor Cap
- Rotor
- Ignition Coil
- High Tension Lead
- Ignition Switch
- Circuit Wiring and Connectors
- TFI Module
- ECM

Fuel System

- Fuel Tank Pickup and Screen
- Fuel Tank Vent
- Anti-Siphon Valve (if equipped)
- Fuel Octane and Quality
- Boat Fuel Lines and Valves
- External Engine Fuel Filter
- Fuel Pump and Line
- Carburetor Fuel Filter or Screen
- Carburetor Adjustments
- Engine PCV Valve (if equipped)
- Flame Arrestor
- Pressure Regulator and Injectors
- TBI

All of the above listed components are not necessarily part of an engine tune-up, but must be considered when attempting to correct engine/boat performance problems. Repair or replace components only as required.

⚠ Do not substitute automotive parts. *Volvo Penta* marine components meet U.S. Coast Guard regulations for external ignition proof operation and marine use. *Volvo Penta* marine components are specially designed not to cause ignition of fuel vapors in the bilge or engine compartment. The use of automotive parts can result in fire and explosion.



Crankcase Capacities

Model	Less Filter	With Filter
3.0 GS	3.5 qts. (3,3 litres)	4.0 qts. (3,8 litres)
4.3 GL, GS, Gi	4.0 qts. (3,8 litres)	4.5 qts. (4.3 litres)
5.0 FL	5.0 qts. (4,7 litres)	6.0 qts. (5,7 litres)
5.7 GL, Gi	5.0 qts. (4,7 litres)	6.0 qts. (5,7 litres)
5.8 FL	5.0 qts. (4,7 litres)	6.0 qts. (5,7 litres)
5.0 Fi	5.0 qts. (4,7 litres)	6.0 qts. (5,7 litres)
5.8 Fi, FSi	4.0 qts. (3,8 litres)	5.0 qts. (4,7 litres)
7.4 GL	5.0 qts. (4,7 litres)	6.0 qts. (5,7 litres)
7.4 Gi, GSi	8.0 qts. (7,6 litres)	9.0 qts. (8,5 litres)
8.2 GL	5.0 qts. (4,7 litres)	6.0 qts. (5,7 litres)

Distributor Specifications

3.0 GS	Sensor Air Gap N/A - <i>Delco</i> ® <i>EST</i> ignition system
	Distributor Rotation clockwise
4.3 GL, GS, Gi	Sensor Air Gap N/A - <i>Delco</i> ® <i>EST</i> ignition system
	Distributor Rotation clockwise
5.0 FL	Sensor Air Gap 0.008 inch (0,203 mm)
	Distributor Rotation counterclockwise
5.0 Fi	Sensor Air Gap N/A - <i>Ford</i> TFI-IV® ignition system
	Distributor Rotation counterclockwise
5.7 Gi	Sensor Air Gap N/A - <i>Delco</i> ® <i>EST</i> ignition system
	Distributor Rotation clockwise
5.8 FL	Sensor Air Gap 0.008 inch (0,203 mm)
	Distributor Rotation counterclockwise
5.8 Fi, FSi	Sensor Air Gap N/A - <i>Ford</i> TFI-IV® ignition system
	Distributor Rotation counterclockwise
7.4 GL	Sensor Air Gap 0.008 inch (0,203 mm)
	Distributor Rotation clockwise
7.4 Gi, GSi	Sensor Air Gap N/A - <i>Delco</i> ® <i>EST</i> ignition system
	Distributor Rotation clockwise
8.2 GL	Sensor Air Gap 0.008 inch (0,203 mm)
	Distributor Rotation clockwise

Engine Firing Order

3.0 GS.....	1-3-4-2
4.3 GL, GS, GI.....	1-6-5-4-3-2
5.0 / 5.8 FL, FI, FSI.....	1-3-7-2-6-5-4-8
5.7 / 7.4 / 8.2 GL, GI, GSI.....	1-8-4-3-6-5-7-2

Fuel Filters

3.0 GS.....	P/N 3855104-0
All Other Models.....	P/N 3851218-2

Fuel Pump Pressure

All Carbureted Models.....	40 - 48 kPa (5.75 - 7 psi)
All Fuel Injected.....	Low 13,8 - 27,6 kPa (2-4 psi)
4.3 / 5.7 GI.....	High 62,0 - 89,6 kPa (9-13 psi)
5.0 / 5.8 FI, FSI.....	High 214 - 269 kPa (31-39 psi)
7.4 GI, GSI.....	High 214 - 269 kPa (31-39 psi)

For more detailed information on fuel injection refer to pertinent Diagnostic Workshop Manuals.

For FI and FSI models, see:

Ford
MFI Diagnostic Workshop Manual (5.0 FI, 5.8 FI/FSI) -

For GI and GSI models see:

TBI Diagnostic Workshop Manual (4.3 GI, 5.7 GI) - GM
MFI Diagnostic Workshop Manual (7.4 GI/GSI) - GM

Idle* and Operating RPM

3.0 GS	
Idle	650-750 RPM
WOT	4200-4600 RPM
4.3 GL	
Idle	550-650 RPM
WOT	4200-4600 RPM
4.3 GS	
Idle	550-650 RPM
WOT	4200-4800 RPM
4.3 Gi	
Idle	600 RPM - Not Adjustable
WOT	4400-4800 RPM
5.0 FL	
Idle	550-650 RPM
WOT	4200-4600 RPM
5.0 Fi	
Idle	600 RPM - Not Adjustable
WOT	4200-4600 RPM
5.7 Gi	
Idle	600 RPM - Not Adjustable
WOT	4200-4600 RPM
5.8 FL	
Idle	550-650 RPM
WOT	4000-4400 RPM
5.8 Fi	
Idle	600 RPM - Not Adjustable
WOT	4200-4600
5.8 FSi	
Idle	600 RPM - Not Adjustable
WOT	4600-5000
7.4 GL	
Idle	550-650 RPM
WOT	4200-4600
7.4 Gi	
Idle	600 RPM - Not Adjustable
WOT	4200-4600
7.4 GSi	
Idle	600 RPM - Not Adjustable
WOT	4800-5200
8.2 GL	
Idle	550-650 RPM
WOT	4400-4800 RPM

*In forward gear

* At Idle RPM

3.0 GS.....	0° TDC - w/87 AKI or higher
4.3 GL and GS.....	0° TDC - w/89 AKI or higher
Shunt-Volvo Penta P/N 885163-6 required	
5° ATDC - w/87 AKI	
5.0 and 5.8 FL.....	10° BTDC - w/ 86 AKI or higher
7.4 GL.....	10° BTDC - w/89 AKI or higher
8.2 GL.....	8° BTDC - w/89 AKI or higher
3° BTDC - w/87 AKI	

Timing* and Fuel Requirements

All Ford Models.....3852820-4

PCV Valves

800 RPM	103-207 KPa (15-30 psi)
2000 RPM.....	276-414 KPa (40-60 psi)

Oil Pressure - All Models

3.0 GS.....	835440-9
4.3 GL, GS, GI.....	841750-3
5.0 FL, FI.....	835779-0
5.7 GI.....	835440-9
5.8 FL, FI, FSI.....	835779-0
7.4 GL, GI, GSI.....	835440-9
8.2 GL.....	835440-9

Oil Filters

SPARK PLUGS

ENGINE	PLUG GAP	TORQUE	VOLVO PENTA P/N	VENDOR P/N
3.0 GL	.045	30Nm (22 ft. lbs)	3851831	AC-MR43LTS
3.0GS	.045	30Nm (22 ft. lbs)	3851831	AC-MR43LTS
4.3GL	.045	30Nm (22 ft. lbs)	3851830	AC-MR43T
4.3GS	.045	30Nm (22 ft. lbs)	3851830	AC-MR43T
4.3Gi	.045	30Nm (22 ft. lbs)	3851855	AC-R43TS
5.0FL	.035	8.7-13.5 Nm (5-10 ft. lbs)	3851833	MC-ASF32C
5.0FI	.035	8.7-13.5 Nm (5-10 ft. lbs)	3851832	MC-AWSF32C
5.7GL	.045	30Nm (22 ft. lbs)	3851830	AC-MR43T
5.7Gi	.045	30Nm (22 ft. lbs)	3851855	AC-R43TS
5.8FL	.035	6.7-13.5 Nm (5-10 ft. lbs)	3851833	MC-ASF32C
5.8Fi	.035	6.7-13.5 Nm (5-10 ft. lbs)	3851856	MC-AWSF22C
5.8FSi	.035	6.7-13.5 Nm (5-10 ft. lbs)	3851856	MC-AWSF22C
7.4GL	.045	30Nm (22 ft. lbs)	3851830	AC-MR43T
7.4Gi	.045	30Nm (22 ft. lbs)	3851855	AC-R43TS
7.4GSI	.045	30Nm (22 ft. lbs)	3851830	AC-MR43T
8.2GL	.045	30Nm (22 ft. lbs)	3851830	AC-MR43T

AC = AC ROCHESTER MC = MOTORCRAFT

General Torque Specifications

The following specifications are for nut and screw sizes not having specific torque recommendations.

U.S. Screw Sizes		Metric Thread Sizes	
N-m	Ft. Lbs.	N-m	Ft. Lbs.
No. 6	...	M-6	6-9
No. 8	...	M-8	14-21
No. 10	2-3,5	M-10	28-40
No. 12	3-4	M-12	50-71
1/4-20	5-7	M-14	80-114
5/8-18	12-14		
3/8-16	20-25		
7/8-14	32-40		
	1,1-1,6		
	2,2-2,8		
	2,7-4,7		
	4,1-5,4		
	6,8-9,5		
	16-19		
	27-34		
	43-54		
			8-12
			19-28
			38-54
			68-96
			108-155

Pound-inches x 0,11298 = newton-meters N·m
 Pound-feet x 1,3558 = newton-meters N·m

Volvo Penta DEALER Service - 20-Hour Check

20-Hour Check includes:

1. Change engine oil and oil filter.
 2. Drain and refill drive unit. Check the trim/tilt reservoir for proper fluid level.
 3. Lubricate steering cable ram with *Volvo Penta Grease*, and check power steering pump reservoir for correct fluid level.
 4. Check tension on all drive belts.
 5. Inspect exhaust system and tighten all hose clamps.
 6. Check engine timing.
 FI models: See Diagnostic Manual - *Ford*
 GI models: See Diagnostic Manual - *GM*.
 7. Carbureted Models Only: Check and adjust carburetor for correct idle mixture and idle RPM.
- For the U.S., Canada, and Mexico, the 20-Hour Check is paid for by the boat owner and performed by your *Volvo Penta* dealer at local rates. In other markets the Warranty Inspection is paid for according to the Warranty Policy for Importers.
8. Check all engine mount screws for tightness.
 9. Lubricate gimbal bearing grease fitting on transom shield. Lubricate both U-joint grease fittings on drive unit.
 10. Check for any deficiencies, malfunctions, signs of abuse, etc. Correction of any problems at this time will prevent worsening of a minor problem and help ensure a trouble-free boating season.
 11. Check engine alignment.
 12. Change fuel filter/water separator.
 13. Make sure engine can achieve maximum rated RPM.



Battery and Cables

Special Tools Required: Battery Hydrometer

The primary function of the battery is to provide power to operate the starter motor. The battery also supplies power to operate the lights and other electrical equipment which may be used when the engine is not running. On battery ignition systems, the battery must supply the ignition current during the starting period and during the time that the alternator is not producing a sufficient charge to meet operating requirements.

Battery Requirements

The boat should be equipped with a 12 volt battery capable of handling all normal electrical needs. **All Carbureted Volvo Penta Models:** We recommend a 360 amp cold cranking rating at 0° F (-18° C), 115 minutes reserve capacity rating at 80° F (27° C) as a minimum. **All EFI Models:** We recommend a 650 amp cold cranking rating of 0° F (-18° C), 165 minutes reserve capacity rating at 80° F (27° C) as a minimum. A maintenance free battery is acceptable as long as it meets the minimum battery requirements.

Battery Maintenance

There are two things which must be done periodically in order to obtain long life from a battery.

1. The electrolyte must be kept above the plates and separators at all times. The liquid level should be brought up to the level specified by the battery manufacturer. Acid should never be added except when it is definitely known that some has been lost by spilling, and then only by an experienced battery man.

⚠ Battery electrolyte is a corrosive acid and should be handled with care. If electrolyte is spilled or splashed on any part of the body, immediately flush the exposed area with liberal amounts of water and obtain medical aid as soon as possible.

1 2. Be sure that the battery is kept nearly at full charge at all times. The state of charge should be checked at frequent intervals by making specific gravity readings with a battery hydrometer. It is suggested that gravity readings and replacement of evaporated water be made every two weeks. Should the gravity fall more than 0.040 specific gravity below a fully charged gravity reading, remove the battery and have it charged.

Note Full charge specific gravity is 1.260 at 80° F (27° C).

⚠ Do not use a jumper cable and a booster battery to start engine. Remove battery from boat and recharge. Fumes vented during charging battery can lead to an explosion.

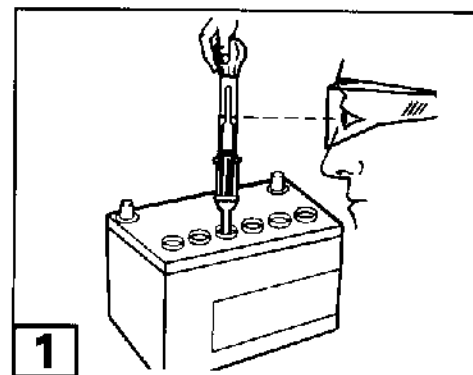

DR3201

