



**ME372STI**

**E ENGINE  
SERVICE MANUAL**

**070031**

**N69-28197-ZJ-11**

# NOTICE

This manual has been prepared by Yamaha primarily for use by Yamaha dealers and their trained mechanics when performing maintenance procedures and repairs to Yamaha equipment. It has been written to suit the needs of persons who have a basic understanding of the mechanical and electrical concepts and procedures inherent in the work, for without such knowledge attempted repairs or service to the equipment could render it unsafe or unfit for use.

Because Yamaha has a policy of continuously improving its products, models may differ in detail from the descriptions and illustrations given in this publication. Use only the latest edition of this manual. Authorized Yamaha dealers are notified periodically of modifications and significant changes in specifications and procedures, and these are incorporated in successive editions of this manual.

**ME372STI  
ENGINE SERVICE MANUAL  
© 2006 Yamaha Motor Co., Ltd.  
1st Edition, December, 2006  
All rights reserved. Any reprinting or  
unauthorized use without the written  
permission of Yamaha Motor Co., Ltd. is  
expressly prohibited.  
Printed in Japan**

---

## HOW TO USE THIS MANUAL

### MANUAL FORMAT

This manual provides the mechanic with descriptions of the operations of disassembly, repair, assembly and check, each of which is presented in a sequential, step-by-step procedure.

To assist you in finding your way around this manual, the section title and major heading is given at the head of each page.

A table of contents is provided on the first page of each section.

### ILLUSTRATIONS

Some illustrations in this manual may differ from the model you have. This is because a procedure described may relate to several models, though only one is illustrated. (The name of the model described will be mentioned in the description).

To help you identify components and understand the correct procedures of disassembly and assembly, exploded diagrams are provided. Steps in the procedure are numbered: 1), 2), 3). Parts shown in the illustrations are identified as: ①, ②, ③.

### REFERENCES

These have been kept to a minimum. References to other sections of the manual include the relevant page number.

---

## IMPORTANT INFORMATION

In this Service Manual particularly important information is distinguished in the following ways.

⚠ The Safety Alert Symbol means ATTENTION! BECOME ALERT! YOUR SAFETY IS INVOLVED!

### **⚠ WARNING**

---

**Failure to follow WARNING instructions could result in severe injury or death to the machine operator, a bystander, or a person inspecting or repairing the machine.**

---

### **CAUTION:**

---

**A CAUTION indicates special precautions that must be taken to avoid damage to the machine.**

---

### **NOTE:**

---

**A NOTE provides key information to make procedures easier or clearer.**

---

# CONSTRUCTION OF THIS MANUAL

This manual consists of chapters for the main categories of subjects. (See "Symbols" on the next page.)

1st title ① : This is a chapter with its symbol on the upper right of each page.

2nd title ② : This title appears on the top of the each page, to the left of the chapter symbol.

3rd title ③ : This title precedes the paragraphs describing the working procedure.

All the procedures in this manual are organized in a sequential, step-by-step order. The information has been compiled to provide the mechanic with an easy-to-read, handy reference that contains comprehensive explanations of all disassembly, check, repair, and assembly procedures.

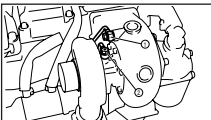
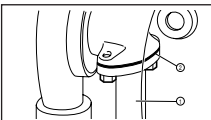
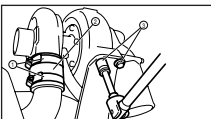
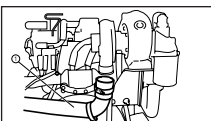
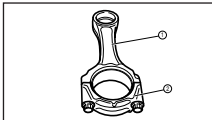
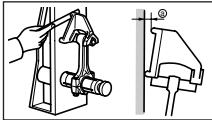
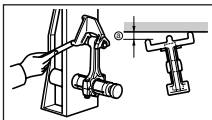
Important procedures including removing, checking, and assembling steps ④ are explained in detail.








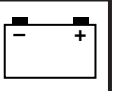














## IMPORTANT FEATURES

- Important engine data and information about special tools framed in a box together with an illustrative symbol ⑤.
- A circled numeral ⑥ indicates a part name. A circled lower case letter indicates data or an alignment mark ⑦.
- An arrow ⑧ indicates the course of action required to remedy the started condition of a component.

## EXPLODED DIAGRAM

Each chapter begins with exploded diagrams which facilitate correct disassembly and assembly.

<p>① → <b>ENG OVER</b> ② <b>TURBOCHARGER</b> ③ <span style="float: right;">④</span></p> <p><b>Turbocharger Removal</b></p> <p>1. Remove:</p> <ul style="list-style-type: none"> <li>• Turbocharger</li> </ul> <p><b>Turbocharger removal steps</b></p> <ol style="list-style-type: none"> <li>1) Drain the coolant.</li> <li>2) Remove the air filter.</li> <li>3) Remove the mixing elbow.</li> <li>4) Separate the coolant by-pass pipe ① and the oil pipe ②, then remove the gaskets.</li> </ol> <p><b>NOTE:</b> Place a rag under the coolant by-pass pipe ends to avoid spilling the fluid.</p>     <ol style="list-style-type: none"> <li>5) Remove the oil drain pipe ① and the gasket ②.</li> <li>6) Loosen the clamps ① of the joint hose ②.</li> <li>7) Remove the bolts ③ below the turbocharger.</li> <li>8) Remove the boost pipe ④.</li> </ol>	<p><b>ENG OVER</b> ⑤ <b>CYLINDER BLOCK</b> ⑥ <span style="float: right;">⑦</span></p> <p><b>Connecting Rod and Piston Pin Check</b></p> <p>1. Check:</p> <ul style="list-style-type: none"> <li>• Connecting rod and rod cap</li> <li>• Connecting rod bending</li> <li>• Connecting rod twisting</li> <li>• Piston pin and connecting rod bushing</li> <li>• Piston pin to bushing clearance</li> </ul> <p><b>Connecting rod and rod cap checking step</b></p> <p>1) Check the connecting rod ① and rod cap ② for cracks, bending and/or damage. Cracks/Bending/Damage → Replace the connecting rod assembly.</p>  <p><b>Connecting rod bending checking step</b></p> <p>1) Check the connecting rod bending ③ by use of the rod aligner. Out of specification → Replace the connecting rod assembly.</p>  <p><b>Connecting rod bending:</b> &lt;Limits&gt; 0.05 mm (0.0020 in.) per 100 mm (3.937 in.)</p> <p><b>Connecting rod twisting checking step</b></p> <p>1) Check the connecting rod twisting ④ by use of the rod aligner. Out of specification → Replace the connecting rod assembly.</p>  <p><b>Connecting rod twisting:</b> &lt;Limits&gt; 0.05 mm (0.0020 in.) per 100 mm (3.937 in.)</p>
--	--

① GEN INFO 	② SPEC 
③ CHK ADJ 	④ REM INST 
⑤ FUEL 	⑥ ENG OVER 
⑦ STEER 	⑧ ELEC 
⑨ TRBL 	⑩ 
⑪ 	⑫ 
⑬ 	⑭ 
⑮ 	⑯ 
⑰ 	⑱ 
⑲ 	⑳ 
㉑ 	㉒ 

## SYMBOLS

Symbols ① to ⑨ are designed as thumb-tabs and indicate the content of a chapter.

- ① General information
- ② Specifications
- ③ Periodic check and adjustment
- ④ Engine removal and installation
- ⑤ Fuel system
- ⑥ Engine overhaul
- ⑦ Power steering system
- ⑧ Electrical system
- ⑨ Troubleshooting

Symbols ⑩ to ⑯ indicate specific data:

- ⑩ Special tool
- ⑪ Recommended fuel
- ⑫ Lubricant
- ⑬ Engine speed
- ⑭ Tightening torque
- ⑮ Specified value, service, limit
- ⑯ Resistance ( $\Omega$ ), Voltage (V), Electric current (A)










Symbols ⑰ to ⑳ in an exploded diagram indicate grade of lubricant and location of lubrication point:

- ⑰ Apply Yamaha marine diesel engine oil
- ⑱ Apply molybdenum disulfide oil
- ⑲ Apply water resistant grease (Yamaha marine grease A)
- ⑳ Apply corrosion resistant grease (Yamaha marine grease D)

Symbols ㉑ and ㉒ in an exploded diagram indicate grade of sealing or locking agent, and location of application point:

- ㉑ Apply LOCTITE® No. 243, 271, 572
- ㉒ Apply ThreeBond® TB-1207B, 1322, 1324

# CONTENTS

<b>GENERAL INFORMATION</b>	 GEN INFO	<b>1</b>
<b>SPECIFICATIONS</b>	 SPEC	<b>2</b>
<b>PERIODIC CHECK AND ADJUSTMENT</b>	 CHK ADJ	<b>3</b>
<b>ENGINE REMOVAL AND INSTALLATION</b>	 REM INST	<b>4</b>
<b>FUEL SYSTEM</b>	 FUEL	<b>5</b>
<b>ENGINE OVERHAUL</b>	 ENG OVER	<b>6</b>
<b>POWER STEERING SYSTEM</b>	 STEER	<b>7</b>
<b>ELECTRICAL SYSTEM</b>	 ELEC	<b>8</b>
<b>TROUBLESHOOTING</b>	 TRBL	<b>9</b>

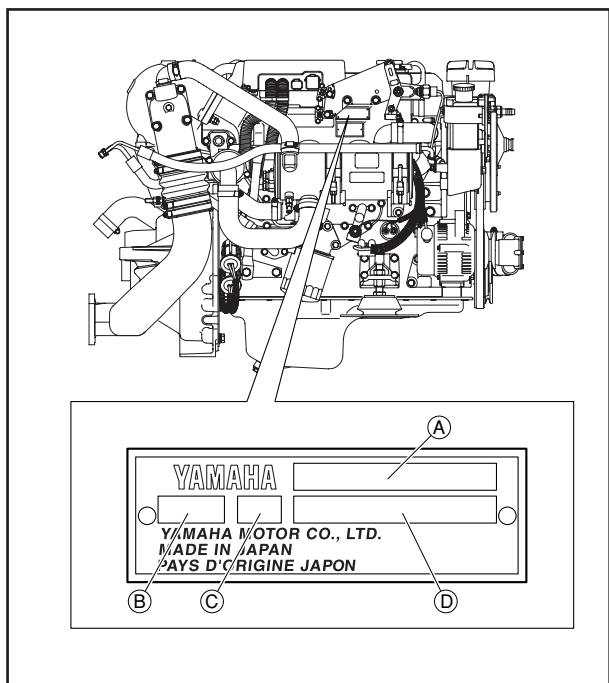




# CHAPTER 1 GENERAL INFORMATION



<b>ENGINE IDENTIFICATION .....</b>	<b>1-1</b>
<b>ENGINE AND PROPELLER ROTATION .....</b>	<b>1-1</b>
<b>SAFETY WHILE WORKING .....</b>	<b>1-2</b>
Fire Prevention .....	1-2
Ventilation .....	1-2
Self-protection .....	1-2
Oils, Greases and Sealing Fluids .....	1-2
Good Working Practices .....	1-3
<b>SPECIAL TOOLS .....</b>	<b>1-5</b>
<b>OTHER EQUIPMENT TOOLS .....</b>	<b>1-8</b>
<b>HANDLING OF LIQUID GASKET .....</b>	<b>1-9</b>
Sealant Application Points and Types of Sealant to Be Applied .....	1-9
<b>STANDARD ABBREVIATIONS AND SYMBOLS .....</b>	<b>1-10</b>
Measurement .....	1-10
Color Codes .....	1-10



## ENGINE IDENTIFICATION

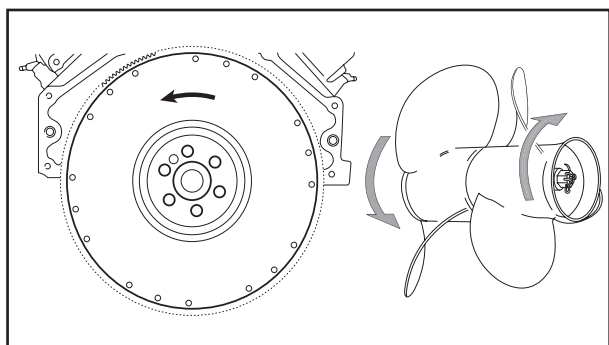
When servicing, inspecting or ordering the spare part of the engine or marine gear, check the identification number as follows.

**NOTE:**

Because of the identification number plate is stuck with special method, the engine number and the serial number will be invalid when removed.

The model and serial number plate is attached on the side of the exhaust manifold. The different models can be identified by checking the model and serial number plate and using the following table.

MODEL	PREFIX	VARIATION	SERIAL NO.
(A)	(B)	(C)	(D)
ME372STI P1	N691	P	*****
	N692	P	*****



## ENGINE AND PROPELLER ROTATION

DO NOT rely on propeller rotation to be in the same direction as engine rotation. Engine rotation is determined by looking at the flywheel end of the engine. The Yamaha engines covered in this manual rotate counterclockwise to the left as viewed from the flywheel.

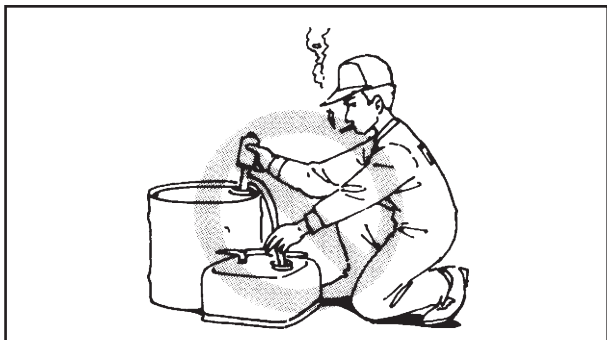


## SAFETY WHILE WORKING

The procedures given in this manual are those recommended by Yamaha to be followed by Yamaha dealers and their mechanics.

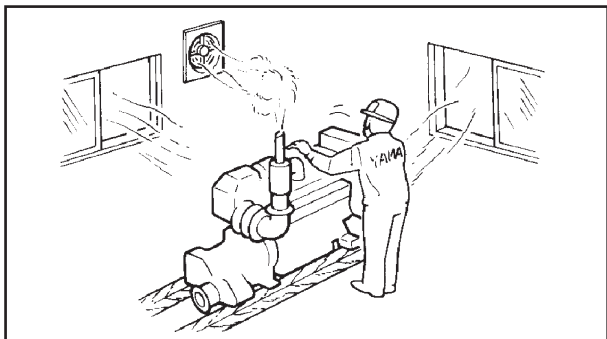
### Fire Prevention

When handling fuel, be sure to keep away from any open flames or heated materials. If spilling fuel, wipe it off immediately.



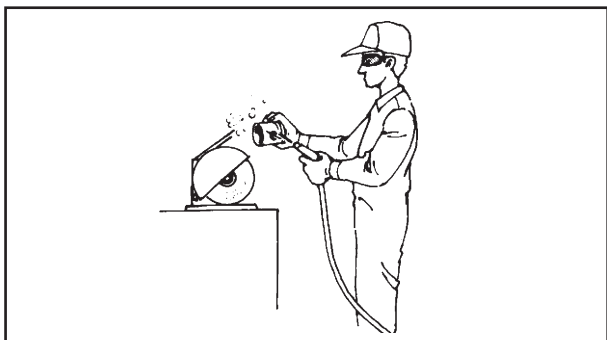
### Ventilation

Engine exhaust gases are harmful to health. When test-running an engine indoors, maintain good ventilation.



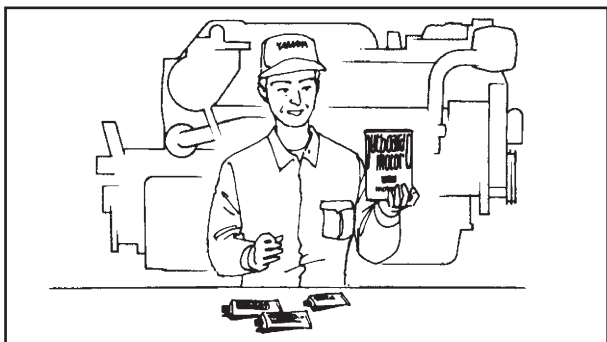
### Self-protection

Protect your eyes with suitable safety glasses or safety goggles, when grinding or when doing any operation which may cause particles to fly off. Protect hands and feet by wearing safety gloves or protective shoes if appropriate to the work you are doing.



### Oils, Greases and Sealing Fluids

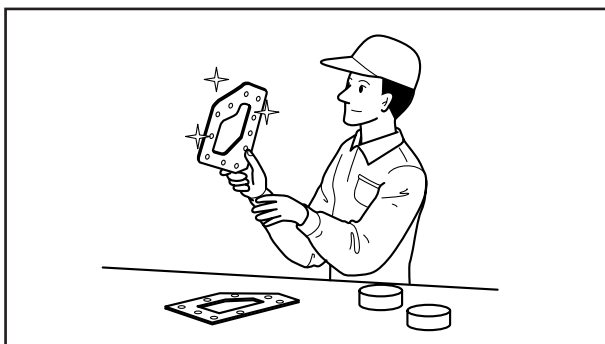
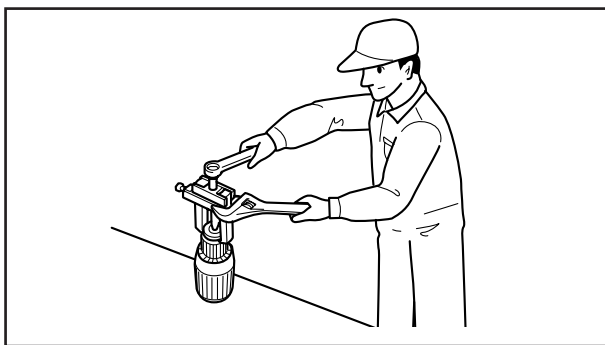
Use only genuine Yamaha oils, greases and sealing fluids or those recommended by Yamaha.



**NOTE:**

Under normal conditions or use, there should be no hazards from the use of the lubricants mentioned in this manual, but safety is all-important, and by adopting good safety practices, any risk is minimized. A summary of the most important precautions is as follows:

1. While working, maintain good standards of personal and industrial hygiene.
2. Clothing which has become contaminated with lubricants should be changed as soon as practicable, and laundered before further use.
3. Avoid skin contact with lubricants; do not, for example, place a soiled wiping-rag in your pocket.
4. Hands and any other part of the body which have been in contact with lubricants or lubricant-contaminated clothing, should be thoroughly washed with hot water and soap as soon as practicable.
5. To protect the skin, the application of a suitable barrier cream to the hands before working, is recommended.
6. A supply of clean lint-free cloths should be available for wiping purposes.

**Good Working Practices****1. The right tools**

- 1) Use the recommended special tools to protect parts from damage. Use the right tool in the right manner - do not improvise.
- 2) When checking with a tester, make sure that battery in the tester can supply sufficient power.

**2. Tightening torque**

Follow the tightening torque instructions. When tightening bolts, nuts and screws, tighten the large sizes first, and tighten inner-positioned fixings before outer-positioned ones.

**3. Non-reusable items**

Always use new gaskets, packings, O-rings, split-pins, circlips, etc., on reassembly.



#### 4. Disassembly and Assembly

- 1) Clean parts with compressed air when disassembling.
- 2) Oil the contact surfaces of moving parts before assembly.

- 3) After assembly, check that moving parts operate normally.

- 4) Install bearings with the manufacturer's markings on the side exposed to view, and liberally oil the bearings. Press the bearing at the outer race when installing it in the bearing case, and press it at the inner race when installing it on the shaft. Keep bearing parallel to the case or the shaft during the press fitting.
- 5) When installing oil seals, apply a light coating of water-resistant grease to the lip and the outside diameter.

**CAUTION:**

**When inspecting and servicing, stop the engine except inspection or service is needed immediately. And wait for the engine cooling down.**



**SPECIAL TOOLS**

The proper special tools are necessary for complete and accurate adjustment and assembly. Using special tools will help avoid damage caused by the use of improper tools or incorrect procedures.

(These special tools are recommended by Yamaha. The tool numbers indicated below are those of TOYOTA Motor Corporation, except for the tools marked with \*.)

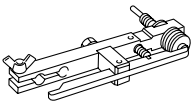
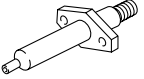
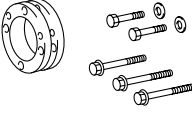
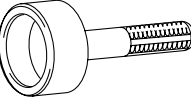
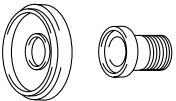
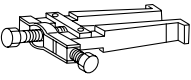
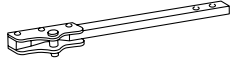

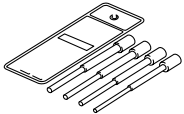
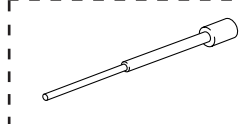
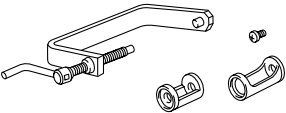
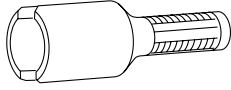
ILLUSTRATION	TOOL No.	TOOL NAME	REMARKS
	09275-54011	Plunger stroke measuring tool	To Check injection timing
	90890-07603	Compression gauge attachment	To measure compression
	09213-58013	Crankshaft pulley holding tool	To secure crankshaft pulley
	09223-56010	Crankshaft rear oil seal replacer	To install crankshaft rear oil seal
	09223-78010	Crankshaft oil seal replacer	To install crankshaft front oil seal
	09308-10010	Oil seal puller	To remove crankshaft front oil seal
	09330-00021	Companion flange holding tool	To secure crankshaft pulley
	09032-00100	Oil pan seal cutter	To remove oil pan
	09201-10000	Valve guide bush remover & replacer set	
	* 09201-01080	Valve guide bush remover & replacer 8	To remove and install valve guide bush
	09202-70020	Valve spring compressor	To remove and install valve
	09214-76011	Crankshaft pulley replacer	To install injection pump drive gear oil seal



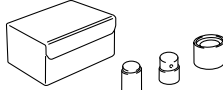
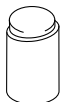
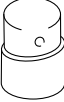

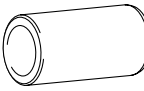

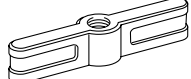
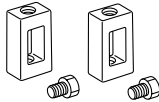
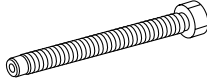
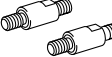
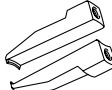
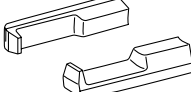

ILLUSTRATION	TOOL No.	TOOL NAME	REMARKS
	09222-58020	Connecting rod bush remover & replacer	
		Remover & replacer	To remove and install connecting rod bush
		Guide	To install connecting rod bush
		Base	To remove and install connecting rod bush
		Cover & seal replacer	To mount crankshaft timing gear and pump drive shaft gear
	09950-40011	Puller B set	
	• 09951-04010	Hanger 150	To remove camshaft timing pulley, pump drive shaft gear, crankshaft timing gear, and injection pump drive gear bearing
	• 09952-04010	Slide arm	To remove camshaft timing pulley, pump drive shaft gear, crankshaft timing gear, and injection pump drive gear bearing
	• 09953-04020	Center bolt 150	To remove camshaft timing pulley, pump drive shaft gear, crankshaft timing gear, and injection pump drive gear bearing
	• 09954-04010	Arm 25	To remove camshaft timing pulley, pump drive shaft gear, crankshaft timing gear, and injection pump drive gear bearing
	• 09955-04011	Claw No. 1	To remove injection pump drive gear bearing
	• 09955-04061	Claw No. 6	To remove camshaft timing pulley, pump drive shaft gear, crankshaft timing gear, and injection pump drive gear bearing
	• 09957-04010	Attachment	To remove injection pump drive gear bearing



ILLUSTRATION	TOOL No.	TOOL NAME	REMARKS
	09950-50013	Puller C set	
	• 09951-05010	Hanger 150	To remove crankshaft pulley and injection pump drive gear
	• 09952-05010	Slide arm	To remove crankshaft pulley and injection pump drive gear
	• 09953-05010	Center bolt 100	To remove injection pump drive gear
	• 09953-05020	Center bolt 150	To remove crankshaft pulley
	• 09954-05021	Claw No.2	To remove crankshaft pulley and injection pump drive gear
	*TCP-2TB (from BANZAI)	Turbocharger pressure gauge	To check for leakage from nozzle leakage pipe #1
	09820-63010	Alternator wrench	To remove and install alternator pulley
	09286-46011	Alternator bearing puller	To remove alternator rectifier end frame and starter motor armature bearing
	09820-00021	Alternator bearing puller	To remove alternator rotor bearing
	09215-00100	Camshaft bearing remover and replacer	To remove and install camshaft bearing





## OTHER EQUIPMENT TOOLS

TOOL NAME	REMARKS
Vernier caliper	
Outside micrometer	0 ~ 25 mm, 25 ~ 50 mm, 50 ~ 75 mm, 75 ~ 100 mm
V Block	
Power wrench (4 times)	
Cylinder gauge	50 ~ 150 mm
Battery hydrometer	
Radiator cap tester	
Compound (Red lead)	
Valve lapping compound	
Hand valve lapper	
Piston ring tool	
Piston oil heater	
Piston vise	
Piston ring compressor	
Straight edge	
Square gauge	
Plasti gauge	
Surface plate	
Digital circuit tester	
Oil pressure gauge	0 ~ 500 kPa
Thickness gauge (Filler gauge)	
Torque wrench	~ 100 kgf/cm, ~ 450 kgf/cm, ~ 900 kgf/cm, ~ 1800 kgf/cm
Dial gauge	
Magnetic base	
Heater gun	
Flat chisel	
Diesel compression gauge set	
Diesel tachometer	
Nozzle tester	
Snap ring plier	
Pin punch	
Thermometer	100 °C
Power steering pump pulley remover	
Power steering pump pulley replacer	



**HANDLING OF LIQUID GASKET**

**Sealant Application Points and Types of Sealant to Be Applied**

Sealant application points	Sealant types to be applied	Standing time required after assembly	Reference page No.
Stiffening plate x Cylinder block	ThreeBond® TB-1207B	2 hours	6-119
Plug x Cylinder block			6-162
Heat exchanger x Gasket			6-22
Heat exchanger side plates x Gasket			6-22
Intercooler rear side x Gasket			6-34
Oil pan x Stiffening plate			6-119
Cylinder head x Tight plug	ThreeBond® TB-1324	1 hour	–
Cylinder block x Tight plug			–
Rear engine mount x Between the nut and bolt	ThreeBond® TB-1322	1 hour	4-5
2-stage rate coupling x Damper stud threads	LOCTITE® No. 271	2 hour	6-6
2-stage rate coupling x Nuts			6-6
Screw x Seawater pump	LOCTITE® No. 572	6 hour	6-15
Heat exchanger x Bolt threads			6-22
Intercooler x Seawater sender threads			6-33
Intercooler x Elbow joint threads			6-33
Intake pipe x Joint plug threads			6-55
Heat exchanger x Anodes	LOCTITE® No. 243	1 hour	3-38
Intercooler x Anodes			3-38
Mixing elbow x Plug			6-61
Mixing elbow x Joint plug			6-61
Oil cooler cover x Oil pressure switch			6-125
Thermostat housing x Thremo switch			6-25
Thermostat housing x Water temperature sensor			6-25



**STANDARD ABBREVIATIONS AND SYMBOLS**

**Measurement**

m	: meter	ft or '	: foot
mm	: millimeter	in or "	: inch
L	: liter	gal	: U.S. gallon
N·m	: Newton meter	lb·ft	: pounds foot
Kgf·m	: kilogram meter	lb·in	: pounds inch
m <sup>3</sup>	: cubic meter	ft <sup>3</sup>	: cubic foot

The following abbreviations and symbols are used:

**Color Codes**

B	: Black	P	: Pink
Br	: Brown	Pu	: Purple
G	: Green	R	: Red
Gy	: Gray	Sb	: Sky blue
L	: Blue	T	: Tan
Lg	: Light green	W	: White
O	: Orange	Y	: Yellow

Wiring diagrams use the following standard abbreviations:

For wires which use tracer stripes, the main color is followed by a slash (or dash) and then the tracer color.

For example:

R/G = Red wire with a green tracer stripe

Y/R = Yellow wire with a red tracer stripe

