Service Manual Outline

Section 1 - Important Information

- A - General Information
- B - Maintenance

Section 2 - Removal, Installation and Adjustment

- A - All Models

Section 3 - Sterndrive Unit

- A - Drive Shaft Housing
- D - Gear Housing - Bravo Three

Section 4 - Transom Assembly

- A - Transom

Section 5 - Power Trim

- A - Oildyne Power Trim Pump

Section 6 - Steering Systems

- A - Power Steering

Section 7 - Corrosion Protection

- A - All Models

Important Information

1

Removal, Installation and Adjustment

2

Sterndrive Unit

3

Transom Assembly

4

Power Trim

5

Steering Systems

6

Corrosion Protection

7

Notice

Throughout this publication, Dangers, Warnings and Cautions (accompanied by the International HAZARD Symbol ) are used to alert the mechanic to special instructions concerning a particular service or operation that may be hazardous if performed incorrectly or carelessly. **OBSERVE THEM CAREFULLY!**

These Safety Alerts alone cannot eliminate the hazards that they signal. Strict compliance to these special instructions when performing the service, plus common sense operation, are major accident prevention measures.

DANGER

Immediate hazards which will result in severe personal injury or death.

WARNING

Hazards or unsafe practices which could result in severe personal injury or death.

CAUTION

Hazards or unsafe practices which could result in minor personal injury or product or property damage.

Notice to Users of This Manual

This service manual has been written and published by the Service Department of Mercury Marine to aid our dealers' mechanics and company service personnel when servicing the products described herein.

It is assumed that these personnel are familiar with marine product servicing procedures. Furthermore, it is assumed that they have been trained in the recommended service procedures of Mercury MerCruiser product, including the use of mechanics' common hand tools and the special Mercury Marine or recommended tools from other suppliers.

We could not possibly know of and advise the marine trade of all conceivable procedures and of the possible hazards and/or results of each method. Therefore, anyone who uses a service procedure and/or tool, which is not recommended by the manufacturer, first must completely satisfy himself that neither his nor the product's safety will be endangered.

All information, illustrations, and specifications contained in this manual are based on the latest product information available at the time of publication. As required, revisions to this manual will be sent to all dealers contracted by us to sell and/or service these products.

We reserve the right to make changes to this manual without prior notification.

Refer to dealer service bulletins, operation maintenance and warranty manuals and installation manuals for other pertinent information concerning the products described in this manual.

Precautions

It should be kept in mind, while working on the product, that the electrical system and ignition system are capable of violent and damaging short circuits or severe electrical shocks. When performing any work where electrical terminals could possibly be grounded or touched by the mechanic, the battery cables should be disconnected at the battery.

Any time the intake or exhaust openings are exposed during service they should be covered to protect against accidental entrance of foreign material which could enter the cylinders and cause extensive internal damage when the engine is started.

It is important to note, during any maintenance procedure replacement fasteners must have the same measurements and strength as those removed. Numbers on the heads of the metric bolts and on the surfaces of metric nuts indicate their strength. American bolts use radial lines for this purpose, while most American nuts do not have strength markings. Mismatched or incorrect fasteners can result in damage or malfunction, or possibly personal injury. Therefore, fasteners removed should be saved for reuse in the same locations whenever possible. Where the fasteners are not satisfactory for reuse, care should be taken to select a replacement that matches the original.

Engine Mechanical Components

Many of the engine mechanical components are designed for marine applications. Unlike automotive engines, marine engines are subjected to extended periods of heavy load and wide open throttle operation and, therefore, require heavy-duty components. Special marine engine parts have design and manufacturing specifications that are required to provide long life and dependable performance. Marine engine parts also must be able to resist the corrosive action of salt or brackish water that will rust or corrode standard automotive parts within a short period of time.

Failure to use recommended Quicksilver service replacement parts can result in poor engine performance and/or durability, rapid corrosion of parts subjected to salt water and possibly complete failure of the engine.

Replacement Parts

Use of parts other than the recommended service replacement parts will void the warranty on those parts that are damaged as a result.

WARNING

Electrical, ignition, and fuel system components on Mercury MerCruiser Engines and Sterndrives are designed and manufactured to comply with U.S. Coast Guard Rules and Regulations to minimize risks of fire or explosion.

Use of replacement electrical, ignition, or fuel system components, which do not comply to these rules and regulations, could result in a fire or explosion hazard and should be avoided.

When servicing the electrical, ignition, and fuel systems, it is extremely important that all components are properly installed and tightened. If not, any electrical or ignition component opening would permit sparks to ignite fuel vapors from fuel system leaks, if they existed.

Models Covered In This Manual

Model	Serial Number
All Bravo Sterndrive Units	0W100000 and Above
All Bravo Transom Models	0W200000 and Above

NOTES:

IMPORTANT INFORMATION

Section 1A - General Information

General Information	1A-2	Propeller Rotation	1A-4
Introduction	1A-3	Sterndrive Unit 10-Hour Break-In Period	
How To Use This Manual	1A-3	(New or With Replacement Gears)	1A-5
Page Identification	1A-3	Serial Number Locations	1A-5
Directional References	1A-4		

IMPORTANT INFORMATION

Section 1B - Maintenance

Torque Specifications	1B-2	Steering Head and Remote Control	
Lubricants / Sealants / Adhesives	1B-2	Maintenance	1B-10
Approved Hydraulic Steering Fluids ...	1B-2	Shift Cable	1B-10
Fluid Capacities	1B-3	Sterndrive Water Drain Holes	1B-11
Special Tools	1B-3	Sterndrive Water Pickups	1B-11
Maintenance Schedules	1B-4	Flushing Attachments	1B-12
Maintenance Intervals	1B-4	Alternative Water Pickups	1B-15
Routine Maintenance	1B-5	Sterndrive Unit Oil	1B-17
Scheduled Maintenance	1B-6	Checking	1B-17
Corrosion Prevention	1B-6	Filling	1B-18
Maintaining Ground Circuit Continuity .	1B-6	Changing	1B-19
Maintaining Anodic Protection	1B-7	Preparing the Power Package for	
Checking Quicksilver MerCathode		Storage	1B-21
System	1B-8	Engine	1B-21
Maintaining Power Package Exterior		Sterndrive	1B-21
Surfaces	1B-8	Power Package Recommissioning ...	1B-26
Boat Bottom Care	1B-8	Engine	1B-26
Anti-fouling Paint	1B-9	Sterndrive	1B-26

REMOVAL, INSTALLATION AND ADJUSTMENT

Section 2A - All Models

Torque Specifications	2A-2	Installing Steering System	2A-27
Lubricants / Sealants / Adhesives	2A-2	Hydraulic (Helm) Steering	2A-27
Special Tools	2A-3	Steering Helm and Cable	2A-27
Transom Thickness and Surface	2A-4	Steering Cable Specifications	2A-28
Special Information	2A-5	Power Steering	2A-29
Bravo Three Notice: Trim-In Limit		MerCathode Quick Connect	2A-34
Insert	2A-5	Shift Cable Installation	2A-35
All Models	2A-6	Bravo Models	2A-36
Propeller Removal	2A-7	Troubleshooting Shift Problems	2A-41
Bravo One and Two	2A-7	Sterndrive Unit Installation	2A-44
Bravo Three	2A-7	Propeller Installation	2A-51
Sterndrive Unit Removal	2A-9	Bravo One and Two	2A-51
Transom Assembly Removal	2A-11	Bravo Three	2A-52
Seawater Inlet Hose	2A-11		
Transom Assembly Installation	2A-17		
Cleaning And Inspection	2A-18		
Reassembly	2A-18		

STERNDRIVE UNIT

Section 3A - Drive Shaft Housing

Identification 3A-2 U-joint Identification 3A-2 Gear Teeth For Drive Ratio 3A-3 Specifications 3A-4 Starting Shim Specification 3A-4 Gear Tooth Count And Gear Lash 3A-4 U-joint Pinion Gear Location 3A-4 U-joint Pinion Gear Shim 3A-4 Driven Gear Thrust Race 3A-5 Torque Specifications 3A-6 U-joint Bearing Assembly Preload 3A-6 Torque Conversion Chart For U-joint Retainer Nut Tool 3A-7 Lubricants / Sealants / Adhesives 3A-8 Special Tools 3A-9 Exploded Views 3A-12 Drive Shaft Housing 3A-12 Clutch Assembly 3A-14 Shifter Assembly 3A-15 Standard Bravo U-joint Assembly 3A-16 Bravo X, XZ, XR and Diesel Bravo U-joint Assembly 3A-17 General Information 3A-18 Assembly Changes 3A-18 U-joint Shim 3A-18 Driven Gear Shim 3A-20	U-joint Assembly 3A-22 Removal 3A-22 Inspection 3A-24 Disassembly 3A-25 Pinion Gear and Bearing Assembly 3A-26 Reassembly 3A-31 U-joint Pinion Gear And Bearing Assembly Preload 3A-33 Setting Preload Using A Vise 3A-33 Setting Preload In The Drive Shaft Housing 3A-37 U-joint Pinion Gear Shimming 3A-40 Feeler Gauge Measurement 3A-48 Measuring Driven Gear Lash 3A-49 Calculation Method For Specified Gear Lash 3A-64 Drive Shaft Housing Reassembly 3A-66 U-joint Pinion Gear And Bearing Assembly Preload 3A-69 Setting Preload Using A Vise 3A-69 Setting Preload In The Drive Shaft Housing 3A-73
--	--

STERNDRIVE UNIT

Section 3D - Gear Housing - Bravo Three

Notice 3D-2 General Information 3D-2 Gear Housing Assembly 3D-2 Propshaft And Propshaft Thrust Bearings 3D-2 Later Model 3D-2 Earlier Model 3D-3	
---	--

TRANSOM ASSEMBLY

Section 4A - Transom

Torque Specifications 4A-2 Bravo Transom Assembly 4A-3 Speedometer Quick Connect 4A-3 Seawater Inlet Hose 4A-4 Removal 4A-4 Cleaning And Inspection 4A-5 Reassembly 4A-5	
--	--

POWER TRIM

Section 5A - Oildyne Power Trim Pump

Specifications	5A-2	Trim Pump Wiring Diagrams	5A-6
Electrical Specification	5A-2	Model With Three-Button	
Exploded View	5A-3	Trim/Trailer Panel	5A-6
Trim Pump And Bracket Hardware	5A-3	Model With Trim In Handle and	
20 Amp Fuse Test	5A-4	Trailer Switch Separate	5A-7
Installation	5A-5		

STEERING SYSTEMS

Section 6A - Power Steering

Power Steering	6A-2
Hydraulic Hose Connection and	
Routing	6A-2

CORROSION PROTECTION

Section 7A - All Models

Torque Specifications	7A-2	Normal Reading But Corrosion Is	
Lubricants / Sealants / Adhesives	7A-2	Evident	7A-33
Special Tools	7A-2	Corrosion On The Entire Sterndrive	
General Information	7A-4	Unit	7A-33
Continuity Circuit	7A-5	Corrosion Problem Developed After	
Trim Cylinder Anodes	7A-9	Refinishing The Sterndrive Unit ..	7A-33
Anodic Plate	7A-10	Paint Blistering On Sterndrive Unit	7A-33
Bravo One Sterndrive Units	7A-10	Trim Cylinder Corroding	7A-34
Bravo Two Sterndrive Units	7A-12	Only One Or Two Components	
Bravo Three Sterndrive Units	7A-13	Corroding	7A-34
Integral MerCathode System	7A-15	Corrosion In The Exhaust Outlet	
Removing Gimbal Mounted		Area	7A-34
MerCathode Assembly	7A-16	Corrosion Occurs After The Unit	
Installing Gimbal Mounted		Is Removed From The Water	7A-34
MerCathode System	7A-18	Corrosion Between Surfaces	7A-34
Connect to MerCathode Controller		Aluminum Corroding In Lubricated	
Assembly	7A-21	Areas	7A-34
Wiring Diagrams	7A-23	Stainless Steel Components	
MerCathode Controller - Quick		Corroding	7A-35
Connect Models	7A-23	Stainless Steel Propeller Corroding	7A-35
Galvanic Isolator	7A-24	Paint Blistering - The Metal Under	
Corrosion Protection Testing and		The Blistered Paint Is Not Pitted ..	7A-35
Troubleshooting	7A-26		
Continuity Test	7A-29		
Test Equipment Set-Up	7A-30		
Low Readings	7A-31		
High Reading	7A-33		

IMPORTANT INFORMATION

Section 1A -General Information



Table of Contents

General Information	1A-2	Propeller Rotation	1A-4
Introduction	1A-3	Sterndrive Unit 10-Hour Break-In Period	
How To Use This Manual	1A-3	(New or With Replacement Gears)	1A-5
Page Identification	1A-3	Serial Number Locations	1A-5
Directional References	1A-4		

General Information

NOTICE

For information and procedures not listed, refer to the appropriate Mercury MerCruiser Service Manual.
--

NOTICE

Refer to appropriate Mercury MerCruiser Service Manual for engine assembly and repair.
--

The following sections of supplemental information have been prepared to assist in the identification and servicing of Mercury MerCruiser shimmable Bravo Sterndrive Units

This supplement is intended to be used in conjunction with **Mercury MerCruiser Service Manual Number 28** and not in place of the manual. The scope of this supplement is to highlight new or different specifications, components, and procedural information as they pertain to the shimmable Bravo Sterndrive Units versus previous Bravo Sterndrive Units.

Introduction

This supplement is designed as a service guide for the models previously listed. It provides specific information, including procedures for disassembly, inspection, assembly, and adjustment to enable dealers and service mechanics to repair the shimmable Bravo Sterndrive Units.

Before attempting repairs it is suggested that the procedure first be read through to gain knowledge of the methods and tools used and the cautions and warnings required for safety.

How To Use This Manual

This manual is divided into sections, which represent major components and systems.

Some sections are further divided into parts that more fully describe the component.

Refer to the Service Manual Outline following Models Covered In This Manual for section titles.

Page Identification

The service manual number and section title appear at the top of the page. Two number groups appear at the bottom of each page. Following is an example and a description.

Page 1A-2

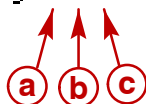

90-17431--4 FEBRUARY 1998

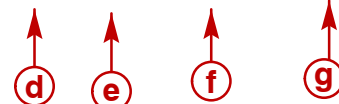

- a** - Section number
- b** - Section part
- c** - Page number
- d** - Manual number
- e** - Revision number
- f** - Month printed
- g** - Year printed

Directional References

Front of boat is bow; rear is stern. Starboard side is right side; port side is left side. In this service manual supplement, all directional references are given as they appear when viewing boat from stern, looking toward bow.

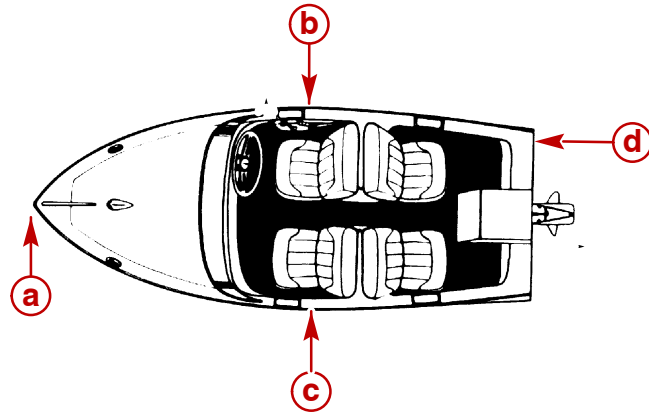

72000

- a** - Fore or bow (front)
- b** - Starboard (right)
- c** - Port (left)
- d** - Aft or stern (rear)

Propeller Rotation

Propeller rotation for sterndrive can be right-hand or left-hand rotation as viewed from the aft end of the propeller.

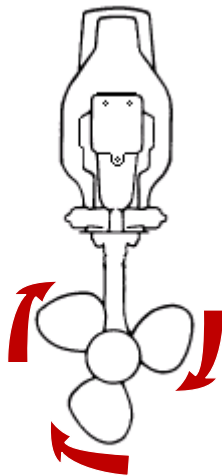
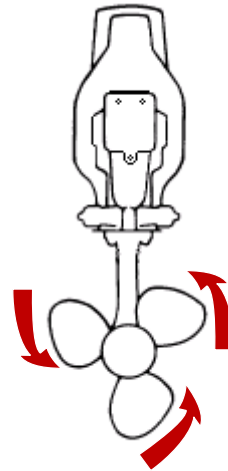
**Right-hand rotation****Left-hand rotation**

79196

Sterndrive Unit 10-Hour Break-In Period (New or With Replacement Gears)

- Avoid full throttle starts.
- Do not operate at any one constant speed for extended periods of time.
- Do not exceed 75% of full throttle during the first 5 hours. During the next 5 hours, operate at intermittent full throttle.
- Sterndrive unit should be shifted into forward gear a minimum of 10 times during break-in, with run-in time at moderate rpm after each shift.

Serial Number Locations

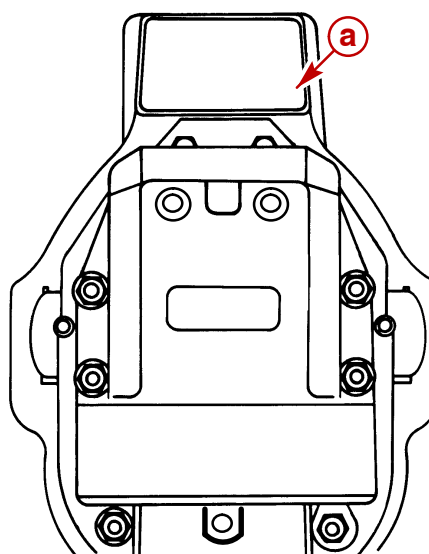

a - Transom assembly serial number

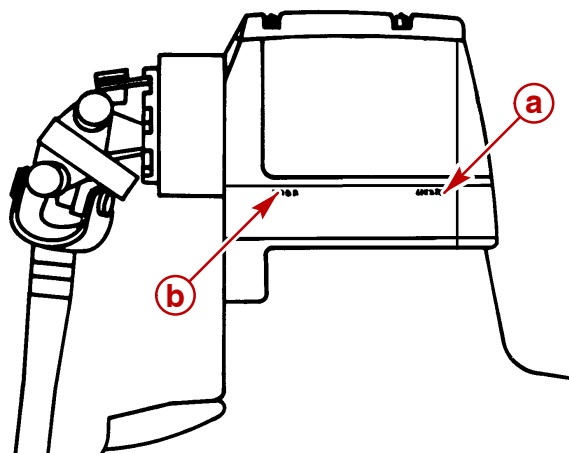

Port side decal

- a** - Sterndrive unit serial number
- b** - Sterndrive unit gear ratio